



# URSA

ATX A - RGB GAMING CASE

EN

ES

FR

DE

IT

PT

## Safety Instructions

- Using the PC tower without proper ventilation can lead to overheating. Ensure that the airflow is unobstructed.
- Never block any ventilation openings. Only place the PC tower in an environment with ample air circulation.
- Avoid exposing the tower to liquids or moisture. Liquids can cause electrical failure and increase the risk of fire or electric shock.
- Do not attempt to repair or disassemble internal components. Only qualified personnel should service the PC tower.
- Keep children away from the packaging materials as they pose a suffocation hazard.







## Cleaning

- Disconnect the power supply and any connected peripherals before cleaning the PC tower.
- Use a soft, dry cloth to clean the exterior of the PC. Avoid using any corrosive liquids or cleaners.
- Ensure that no liquid enters the ventilation openings during cleaning.

## Disposal

- Your PC tower is made from high-quality materials that can be recycled and reused.
- Be aware of your local regulations for electronic waste disposal.
- Follow local guidelines to ensure proper disposal of old electronic products, preventing negative environmental and health impacts.



ITEM	NAME	QUANTITY	USED FOR
	Cable ties	5	Cable management
	Screw #6-32 6.5mm	4	Motherboard stud
	Screw M3 5mm	20	Motherboard / SSD
	Screw #6-32 6mm	6	PSU / PCIe Card
	Screw #6-32 5mm	4	3.5" HDD
	Screw M3 28mm	8	Fan screw
	Rear I/O Cover	1	

## 1. Disassemble the side panel and the front panel

Please remove the side panels before disassembling the front panel

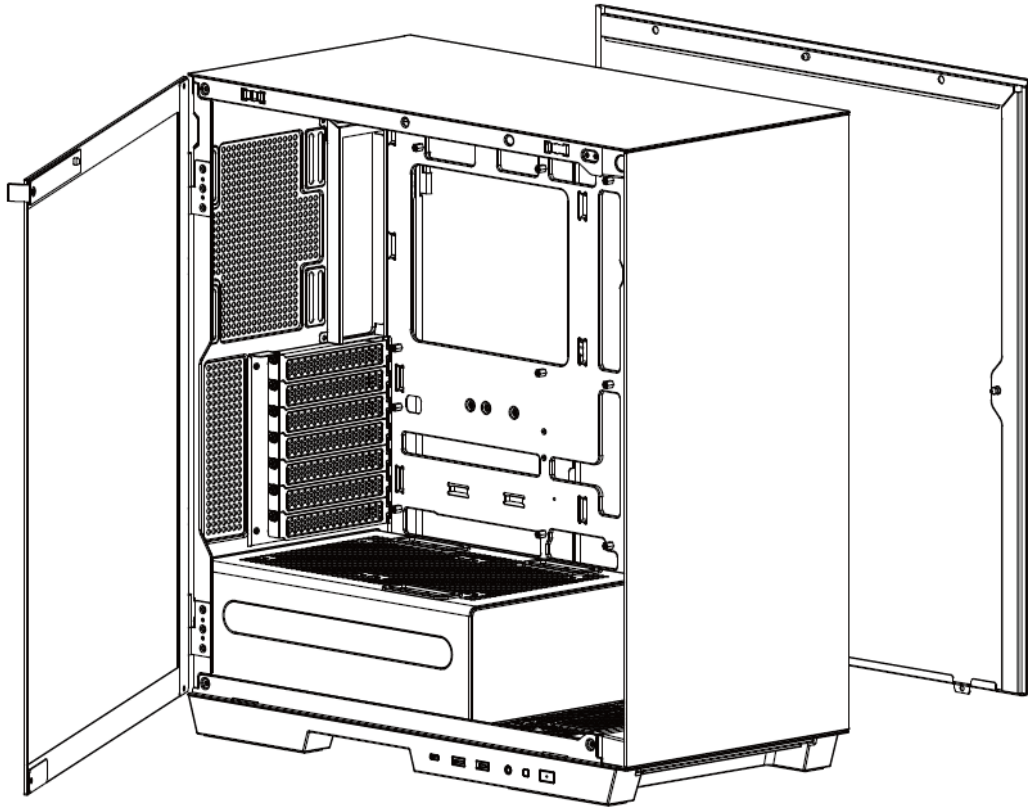

## 2. Install the power supply

Please make sure that the holes of power supply aim at case cooling vents when installing power supply

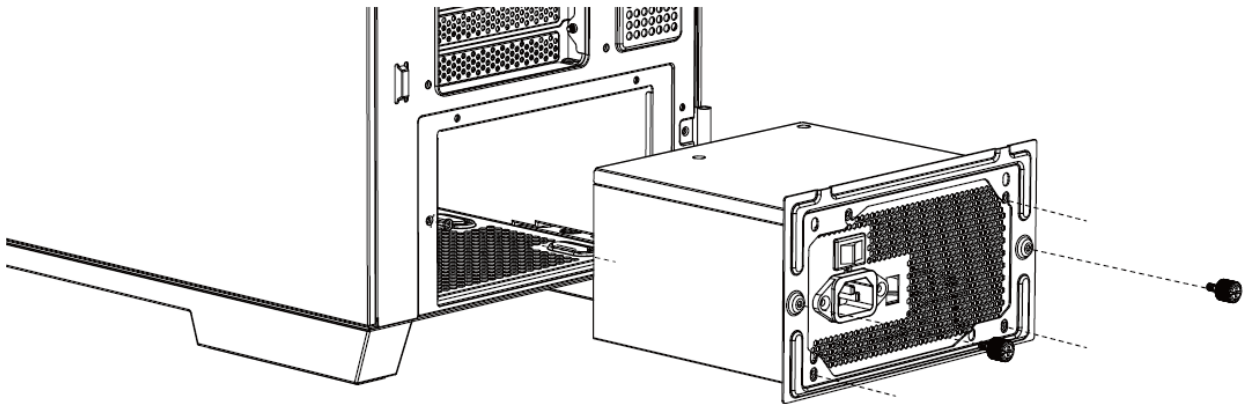

Screw #6-32 6mm

PSU / PCIe Card

### 3. Install the motherboard

Please make sure that the motherboard aims at the copper cylinder and fix motherboard with screw "M3 5mm".

Note: If the copper pillar of the case drops off please fix it with screw "#6-32 6.5mm" copper cylinder.

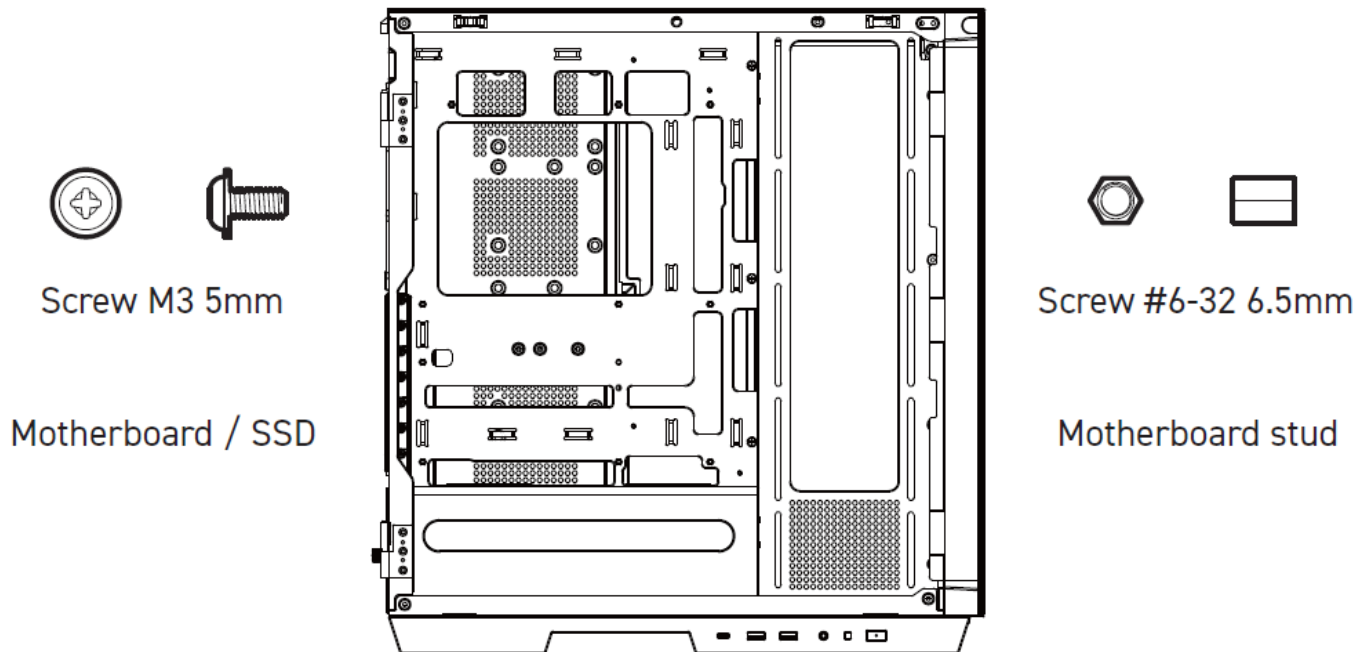

## 4. Install fan and radiator

- Top: 140mm x 2 or 120mm x 3 (Max.)
- Rear: 140mm x 1 (Max.)
- PSU: 120mm x 2 (Max.)
- MB : 120mm x 3 (Max.)
- Bottom : 120mm x 1 (Max.)

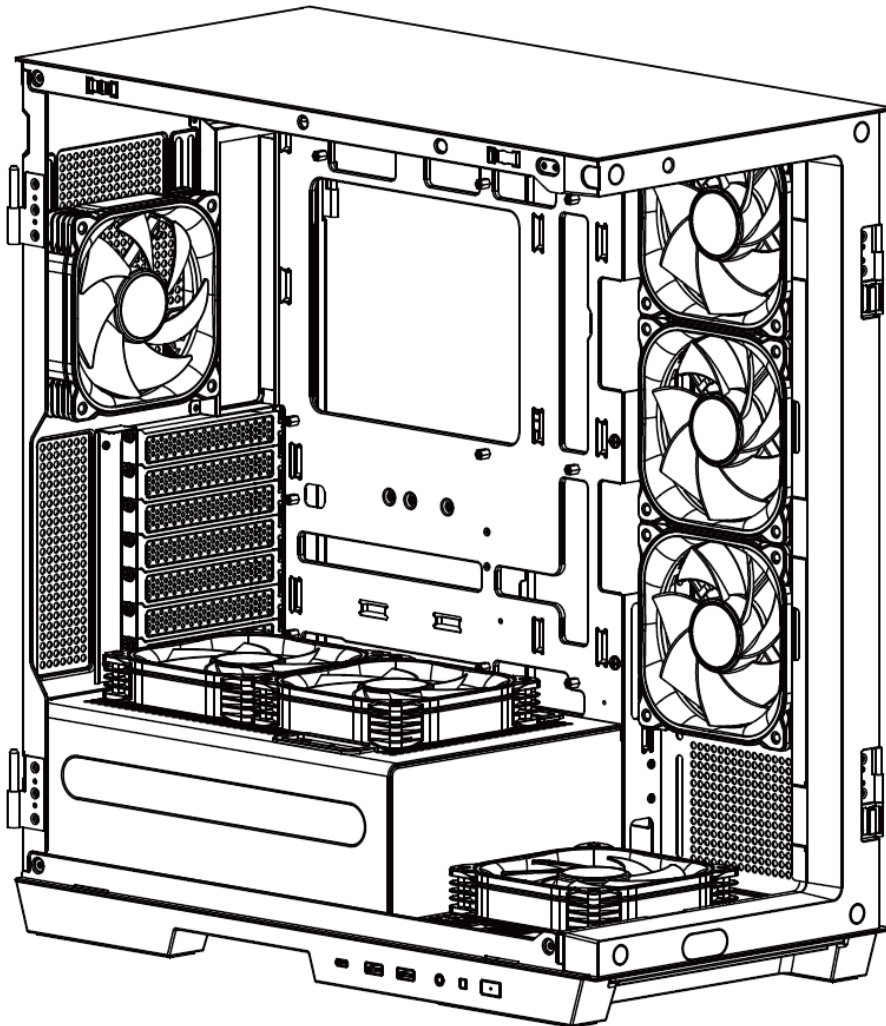

## 5. Install the SSD & HDD

Hard disk enclosure for both SSD and HDD; Unscrew hard disk enclosure and install HDD with screws.

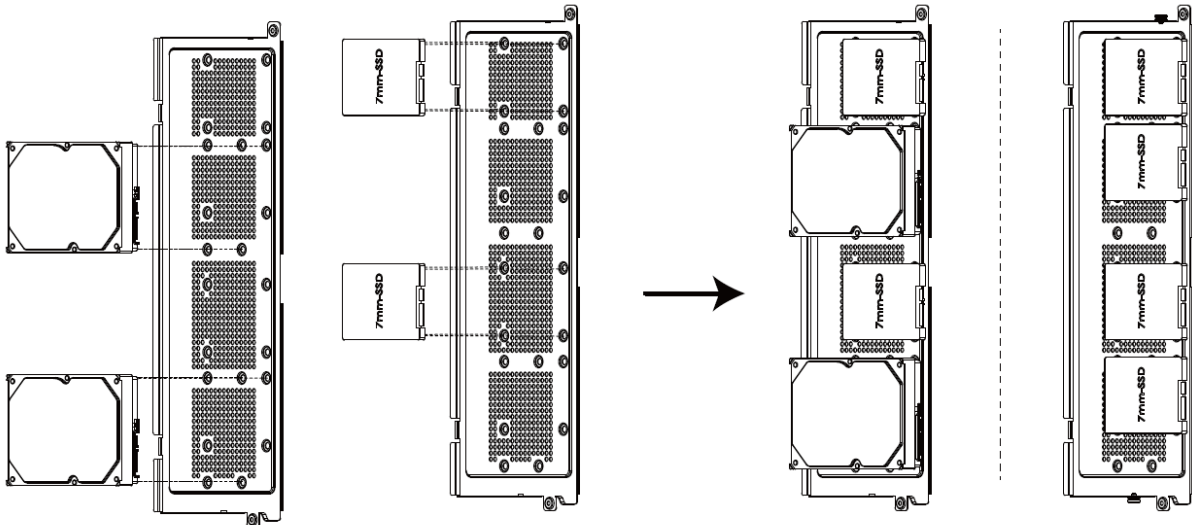
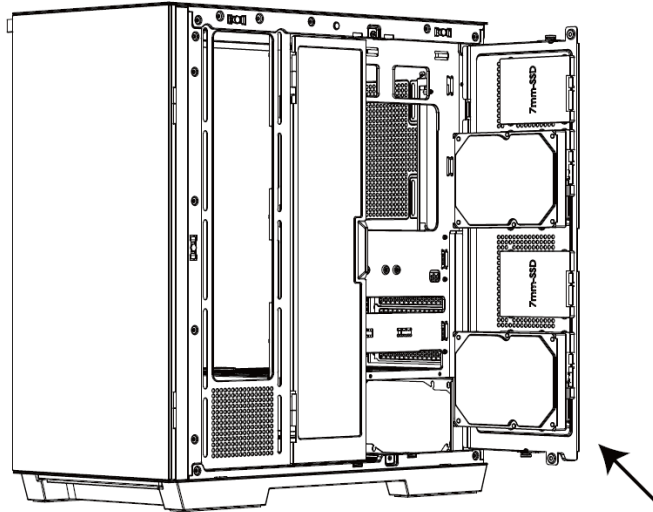

HDD\*2 + SSD\*2

or

SSD\*4



Screw #6-32 5mm

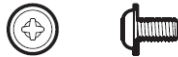

Screw M3 5mm

## 6. Install VGA

Remove the baffle marked in the picture, make sure the VGA card aims at the motherboard slot and then fix VGA card and case with "#6-32 6mm" screw.

VGA card bracket is equipped, which can be adjusted according to VGA card location.

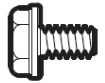
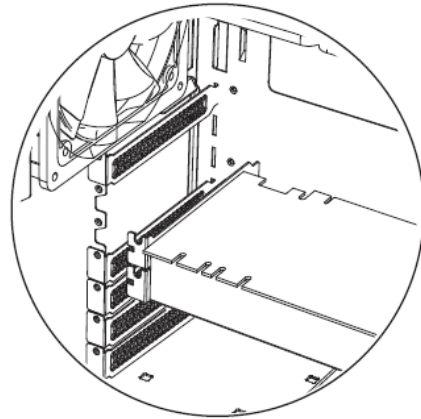
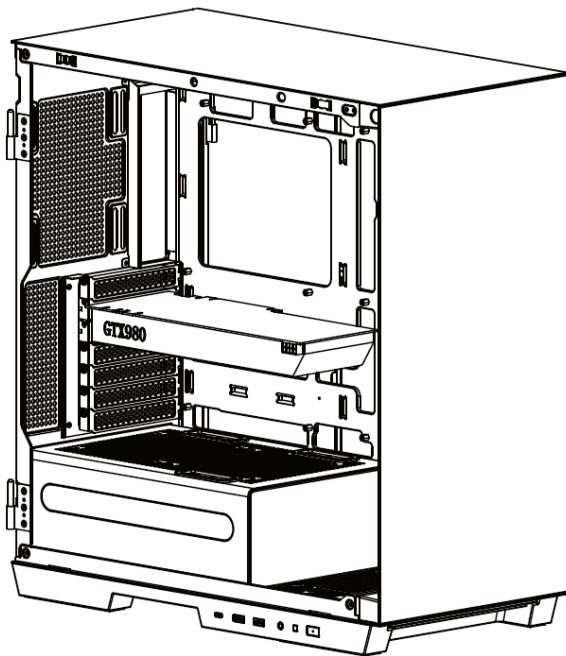

Screw #6-32 6mm

PSU / PCIe Card

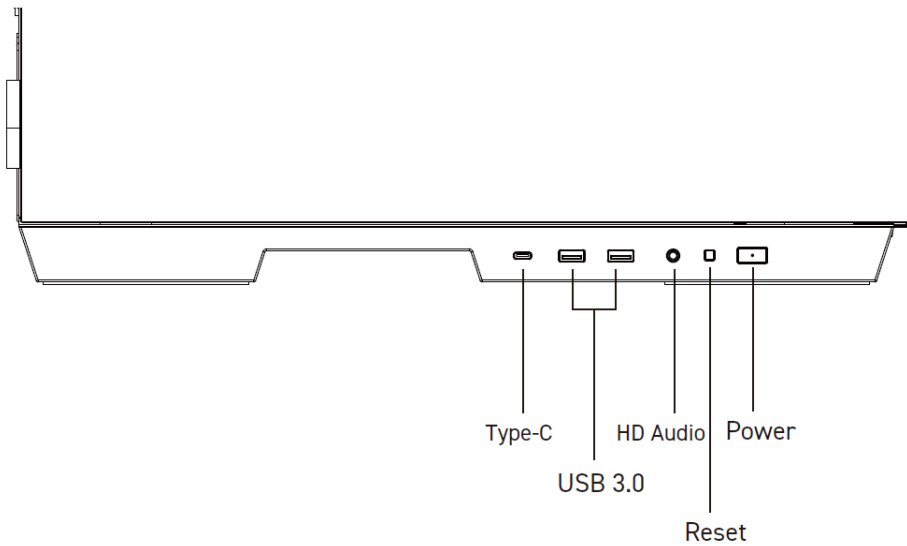

## Connections

Case HD Audio Connector



Case USB Connector

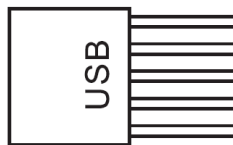

Case USB 3.0 Connector

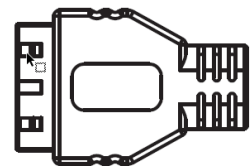

Motherboard Audio Connector



Motherboard USB Connector

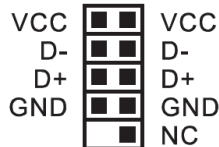

Motherboard USB 3.0 Connector

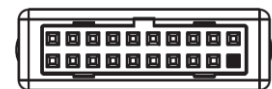

Case Type C connector



Motherboard Type C connector

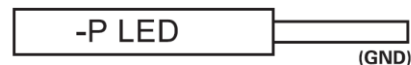
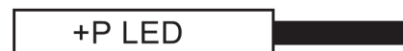

## Instrucciones de seguridad

- El uso de la torre del PC sin la ventilación adecuada puede provocar sobrecalentamiento.
- Asegúrese de que el flujo de aire no esté obstruido. Nunca bloquee las aberturas de ventilación.
- Coloque la torre del PC solo en un entorno con suficiente circulación de aire.
- Evite exponer la torre a líquidos o humedad. Los líquidos pueden causar fallos eléctricos y aumentar el riesgo de incendio o descarga eléctrica.
- No intente reparar ni desmontar los componentes internos. Solo personal cualificado debe dar servicio a la torre del PC.
- Mantenga a los niños alejados de los materiales de embalaje, ya que suponen un riesgo de asfixia.

## Limpieza

- Desconecte la fuente de alimentación y cualquier periférico conectado antes de limpiar la torre del PC.
- Utilice un paño suave y seco para limpiar el exterior del PC. Evite usar líquidos corrosivos o limpiadores.
- Asegúrese de que no entre líquido en las aberturas de ventilación durante la limpieza.

## Desecho

- Su torre de PC está hecha de materiales de alta calidad que pueden ser reciclados y reutilizados.
- Tenga en cuenta las normativas locales para la eliminación de residuos electrónicos.
- Siga las pautas locales para garantizar una correcta eliminación de productos electrónicos viejos, evitando impactos negativos en el medio ambiente y la salud.



ARTÍCULO	NOMBRE	CANTIDAD	USO
	Bridas para cables	5	Gestión de cables
	Tornillo #6-32 6.5mm	4	Tornillo de la placa base
	Tornillo M3 5mm	20	Placa base / SSD
	Tornillo #6-32 6mm	6	PSU / Tarjeta PCIe
	Tornillo #6-32 5mm	4	Disco duro de 3,5"
	Tornillo M3 28mm	8	Tornillo del ventilador
	Cubierta trasera de E/S	1	

## 1. Desmontar el panel lateral y el panel frontal

Retire los paneles laterales antes de desmontar el panel frontal.

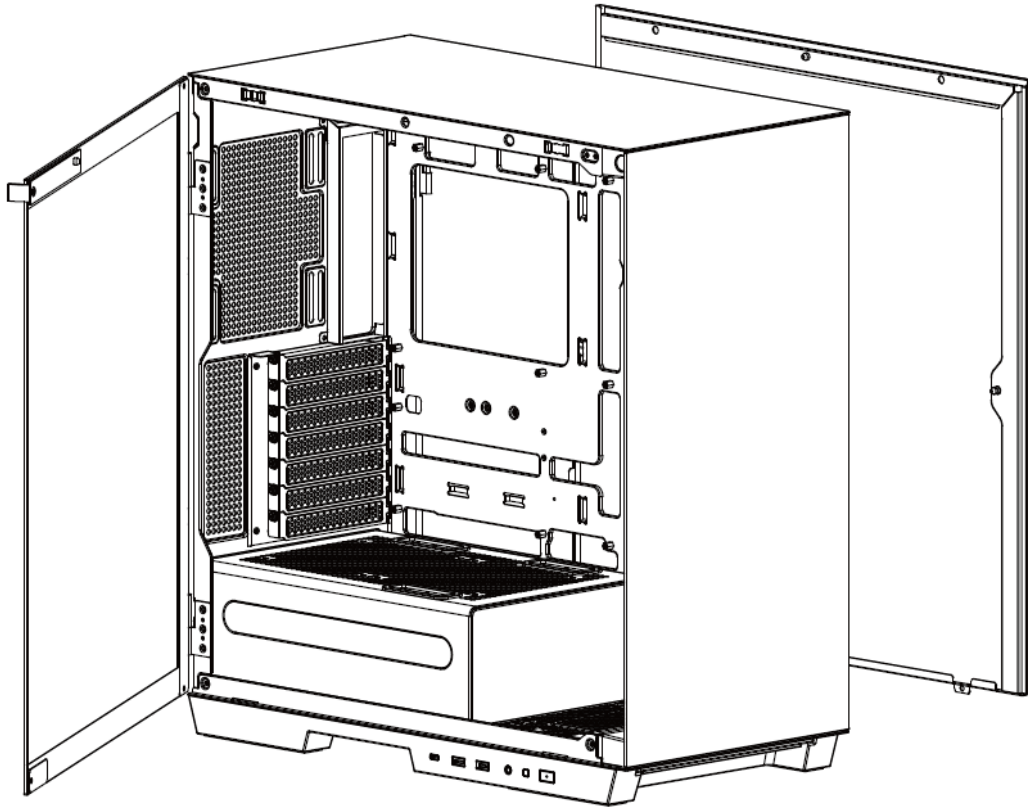

## 2. Retire los paneles laterales antes de desmontar el panel frontal.

Asegúrese de que los orificios de la fuente de alimentación estén alineados con las rejillas de ventilación de la caja al instalarla.

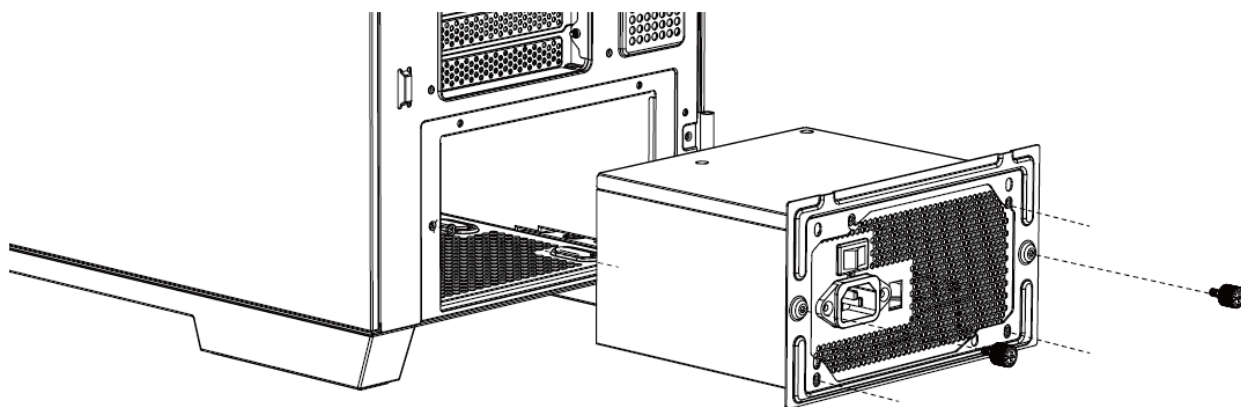

Tornillo #6-32  
6mm

6

PSU / Tarjeta  
PCIe

### 3. Instalar la placa base

Asegúrese de que la placa base esté alineada con el cilindro de cobre y fije la placa base con el tornillo "M3 5mm".

Nota: Si el pilar de cobre de la caja se desprende, fíjelo con el tornillo "#6-32 6.5mm" en el cilindro de cobre.

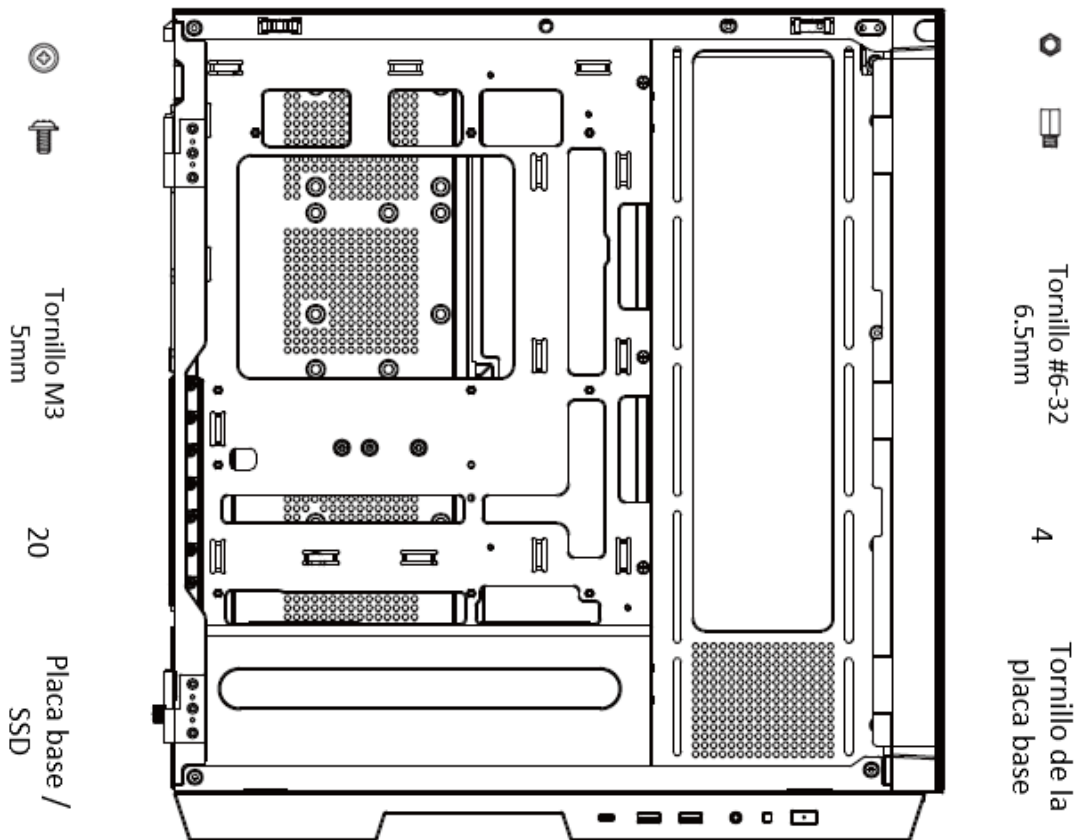

## 4. Instalar el ventilador y el radiador

- Parte superior: 140mm x 2 o 120mm x 3 (máx.)
- Parte trasera: 140mm x 1 (máx.)
- PSU: 120mm x 2 (máx.)
- MB: 120mm x 3 (máx.)
- Parte inferior: 120mm x 1 (máx.)

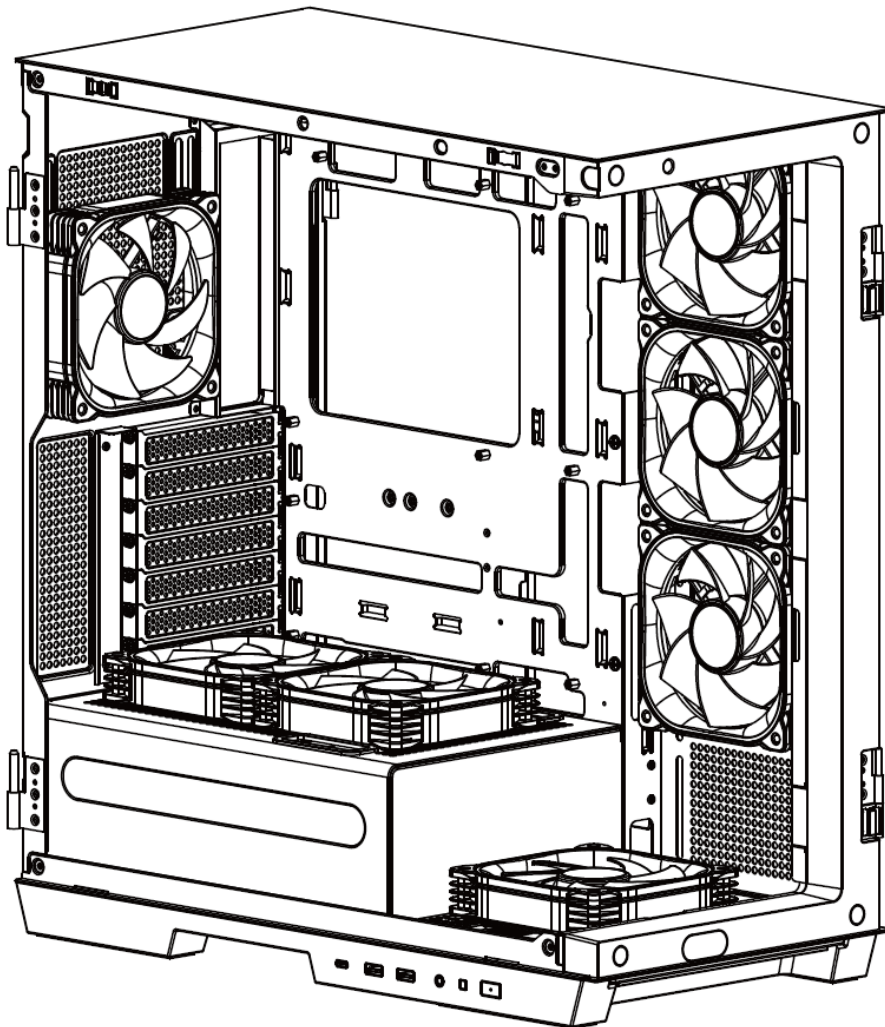

## 5. Instalar SSD y HDD

Carcasa de disco duro para SSD y HDD; Desatornille la carcasa del disco duro e instale el HDD con los tornillos.

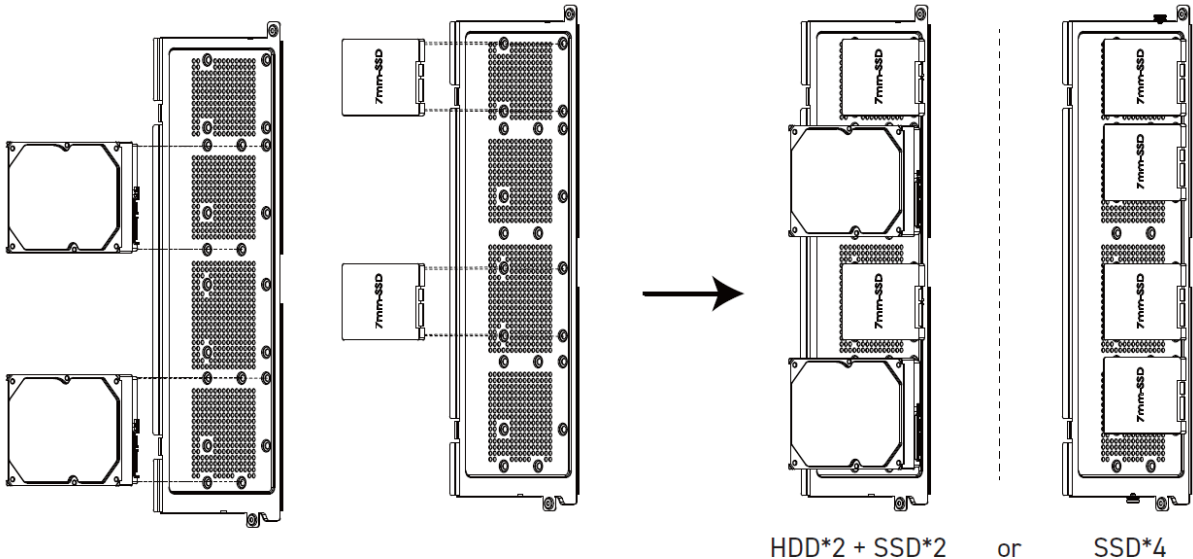
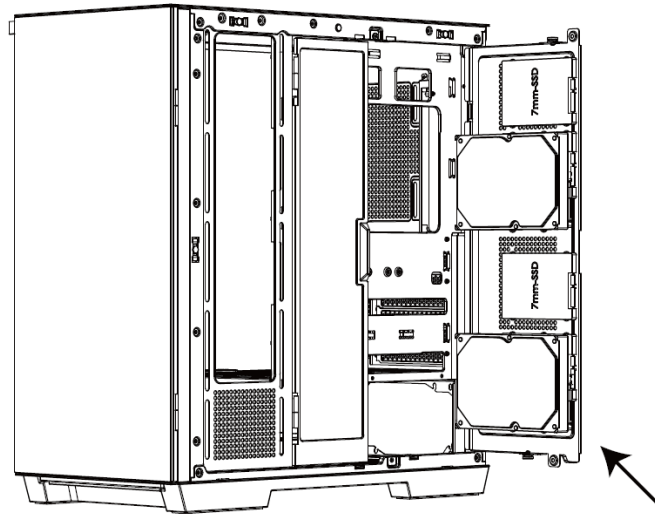

Tornillo #6-32  
5mm

4

Disco duro de  
3,5"



Tornillo M3  
5mm

20

Placa base /  
SSD

## 6. Instalar la tarjeta gráfica (VGA)

Quite el deflector marcado en la imagen, asegúrese de que la tarjeta VGA esté alineada con la ranura de la placa base, y luego fije la tarjeta VGA y la caja con el tornillo "#6-32 6mm".

El soporte de la tarjeta VGA está equipado, y se puede ajustar según la ubicación de la tarjeta VGA.

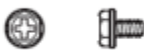
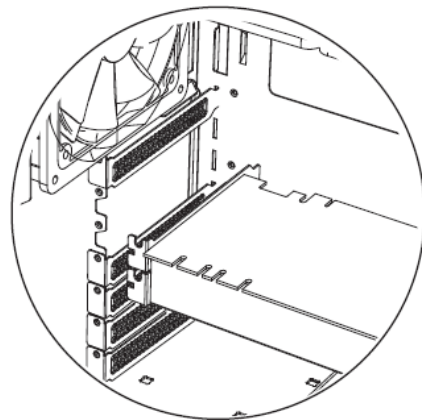
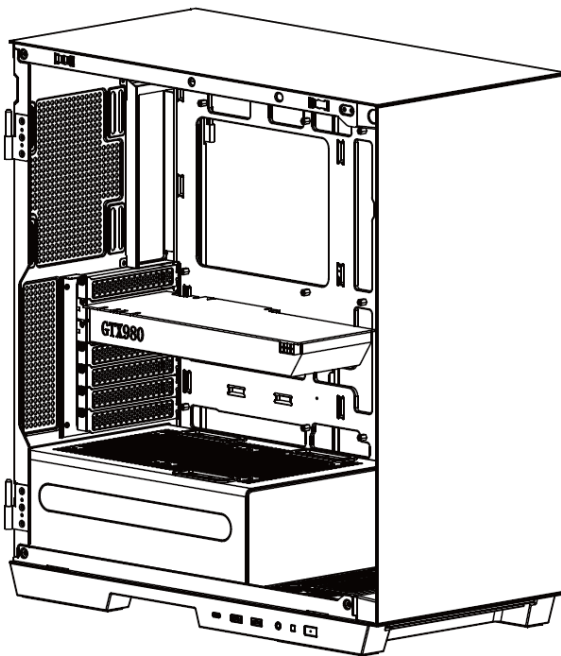

Tornillo #6-32  
6mm

6

PSU / Tarjeta  
PCIe

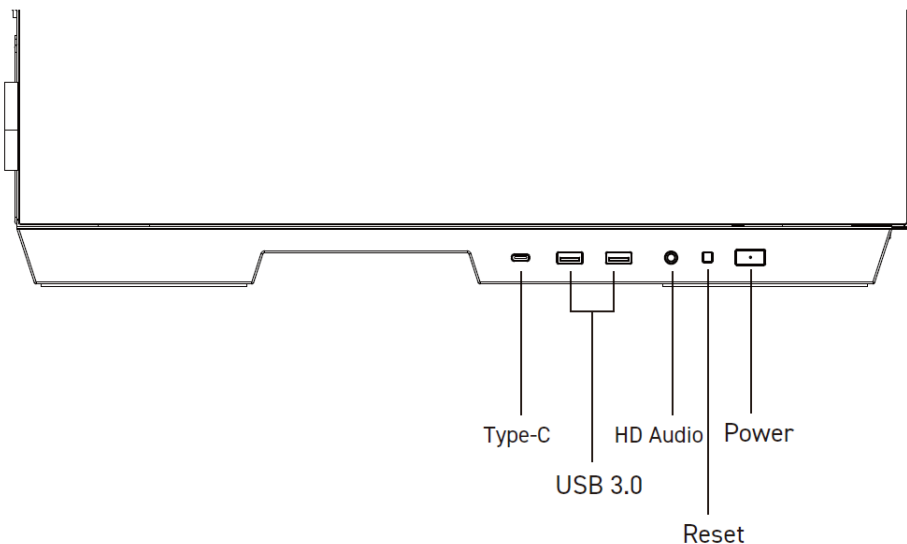

## Conexiones

Conector audio de la caja HD



Conector USB de la caja

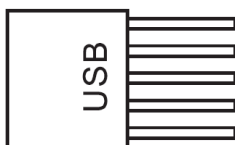

Conector USB 3.0 de la caja

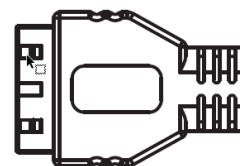

Conector audio de placa base



Conector USB placa base

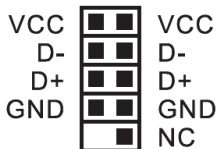

Conector USB 3.0 placa base

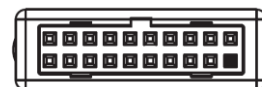

Conector de Tipo C de la caja



Conector Tipo C placa base

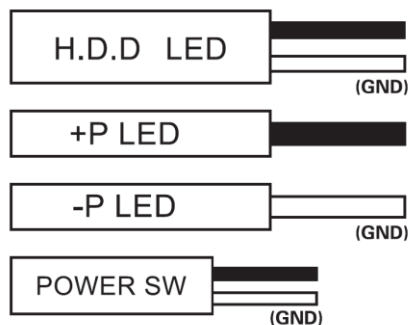

## Instructions de sécurité

- L'utilisation de la tour PC sans ventilation adéquate peut entraîner une surchauffe. Assurez-vous que le flux d'air n'est pas obstrué.
- Ne bloquez jamais les ouvertures de ventilation.
- Placez la tour PC uniquement dans un environnement avec une circulation d'air suffisante. Évitez d'exposer la tour à des liquides ou à l'humidité.
- Les liquides peuvent provoquer des pannes électriques et augmenter le risque d'incendie ou de choc électrique. Ne tentez pas de réparer ou de démonter les composants internes. Seul du personnel qualifié doit intervenir sur la tour PC.
- Tenez les enfants éloignés des matériaux d'emballage car ils présentent un risque d'étouffement.







## Nettoyage

- Débranchez l'alimentation électrique et tous les périphériques connectés avant de nettoyer la tour PC.
- Utilisez un chiffon doux et sec pour nettoyer l'extérieur du PC.
- Évitez d'utiliser des liquides corrosifs ou des nettoyeurs.
- Assurez-vous qu'aucun liquide ne pénètre dans les ouvertures de ventilation pendant le nettoyage.

## Élimination

- Votre tour PC est fabriquée à partir de matériaux de haute qualité qui peuvent être recyclés et réutilisés.
- Soyez conscient des réglementations locales concernant l'élimination des déchets électroniques.
- Suivez les directives locales pour garantir une élimination adéquate des vieux produits électroniques, évitant ainsi les impacts négatifs sur l'environnement et la santé.



ARTICLE	NOM	QUANTITÉ	UTILISATION
	Attaches pour câbles	5	Gestion des câbles
	Vis #6-32 6.5mm	4	Support de carte mère
	Vis M3 5mm	20	Carte mère / SSD
	Vis #6-32 6mm	6	PSU / Carte PCIe
	Vis #6-32 5mm	4	Disque dur 3,5"
	Vis M3 28mm	8	Vis du ventilateur
	Couvercle arrière E/S	1	

## 1. Démontez le panneau latéral et le panneau avant

Veillez retirer les panneaux latéraux avant de démonter le panneau avant.

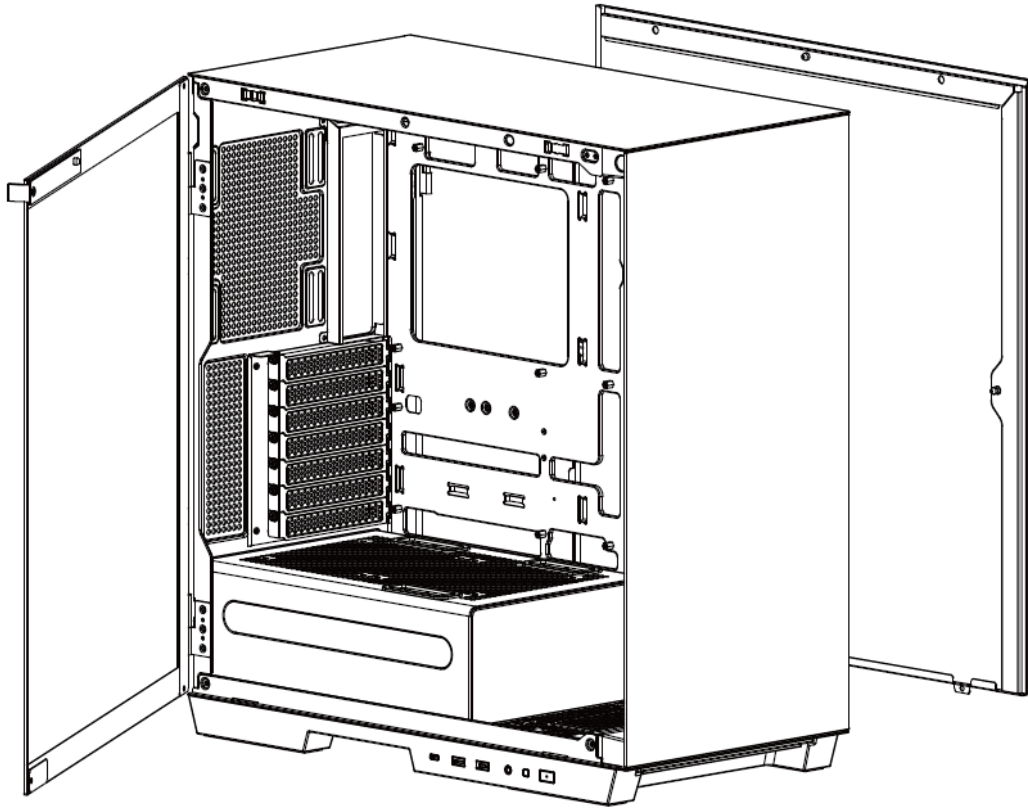

## 2. Installez l'alimentation

Veillez vous assurer que les trous de l'alimentation sont alignés avec les grilles de ventilation du boîtier lors de l'installation.

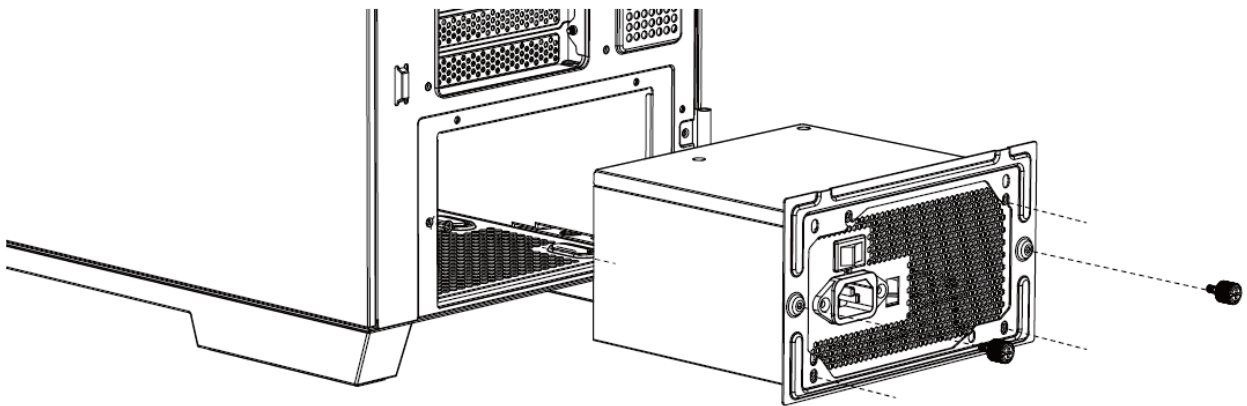

Vis #6-32 6mm

6

PSU / Carte  
PCIe

### 3. Installez la carte mère

Veillez vous assurer que la carte mère est alignée avec le cylindre en cuivre et fixez la carte mère avec la vis "M3 5mm".

Remarque : Si le pilier en cuivre du boîtier se détache, fixez-le avec la vis "#6-32 6.5mm" sur le cylindre en cuivre.

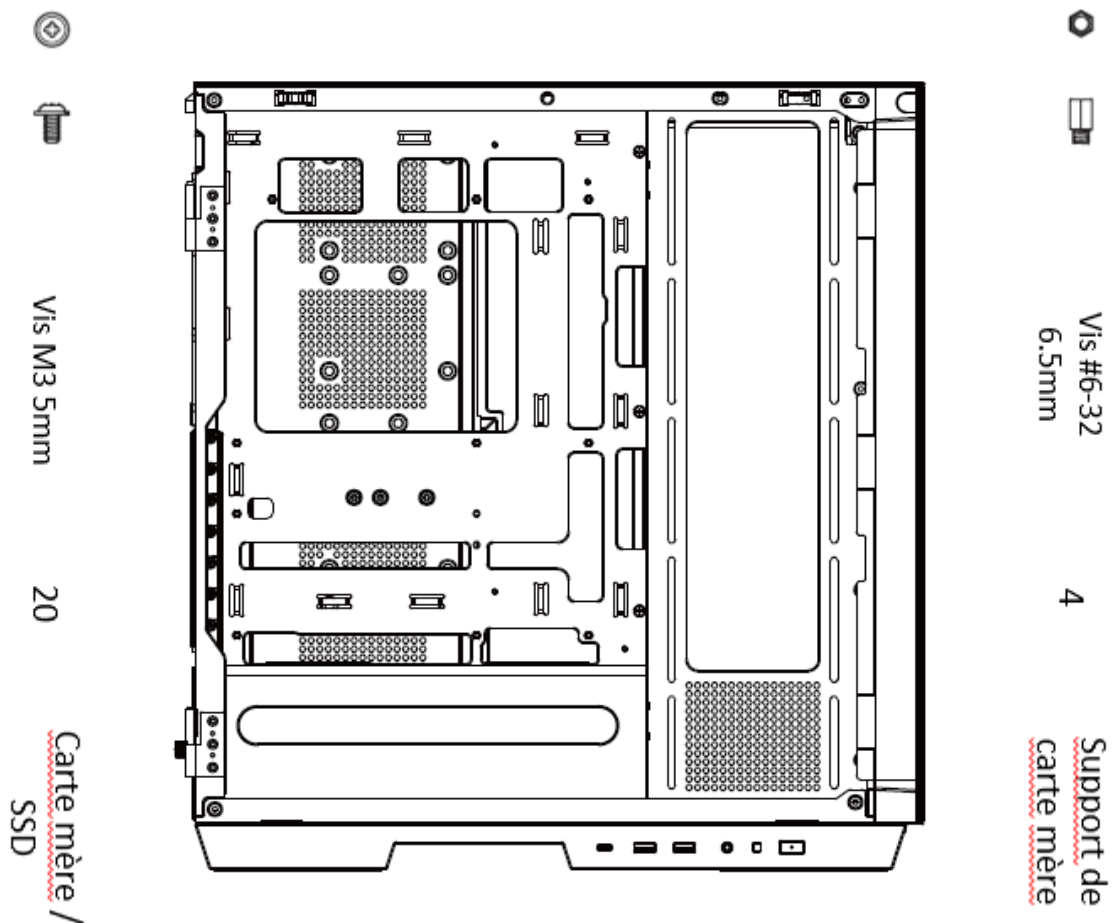

## 4. Installez le ventilateur et le radiateur

- Haut : 140mm x 2 ou 120mm x 3 (Max.)
- Arrière : 140mm x 1 (Max.)
- PSU : 120mm x 2 (Max.)
- MB : 120mm x 3 (Max.)
- Bas : 120mm x 1 (Max.)

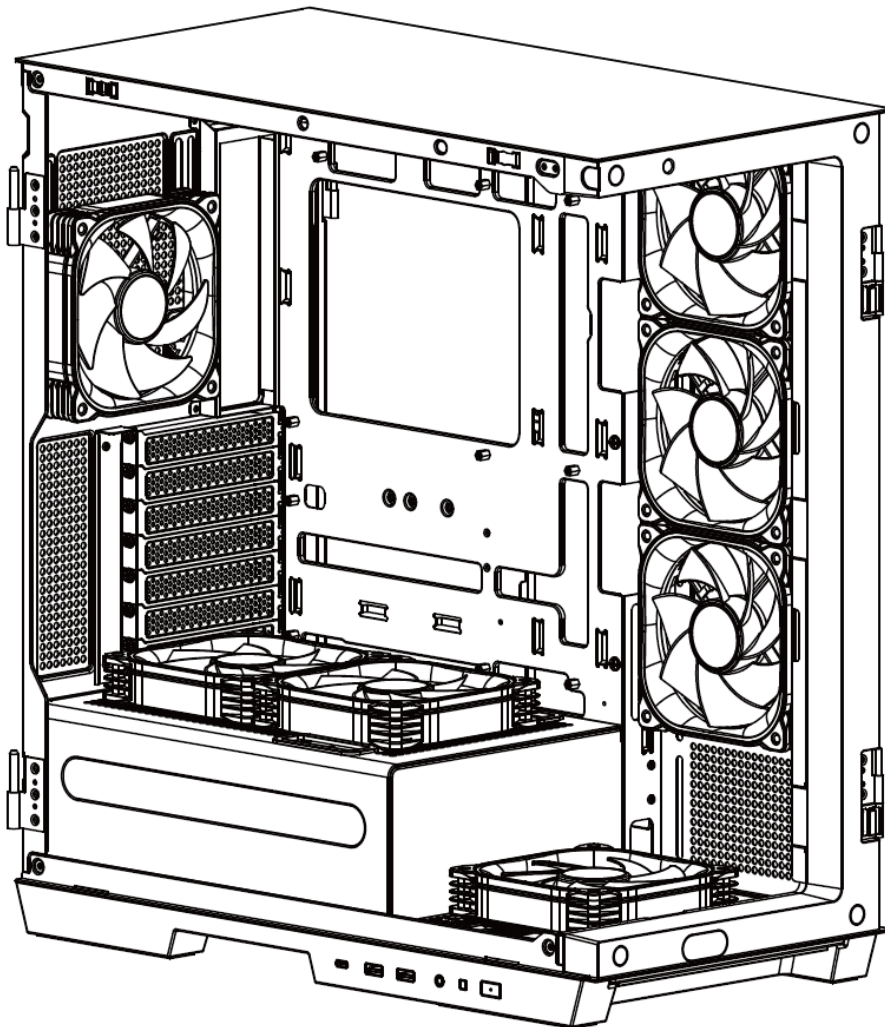

## 5. Installez le SSD & HDD

Boîtier pour disque dur pour SSD et HDD ; Dévissez le boîtier du disque dur et installez le HDD avec les vis.

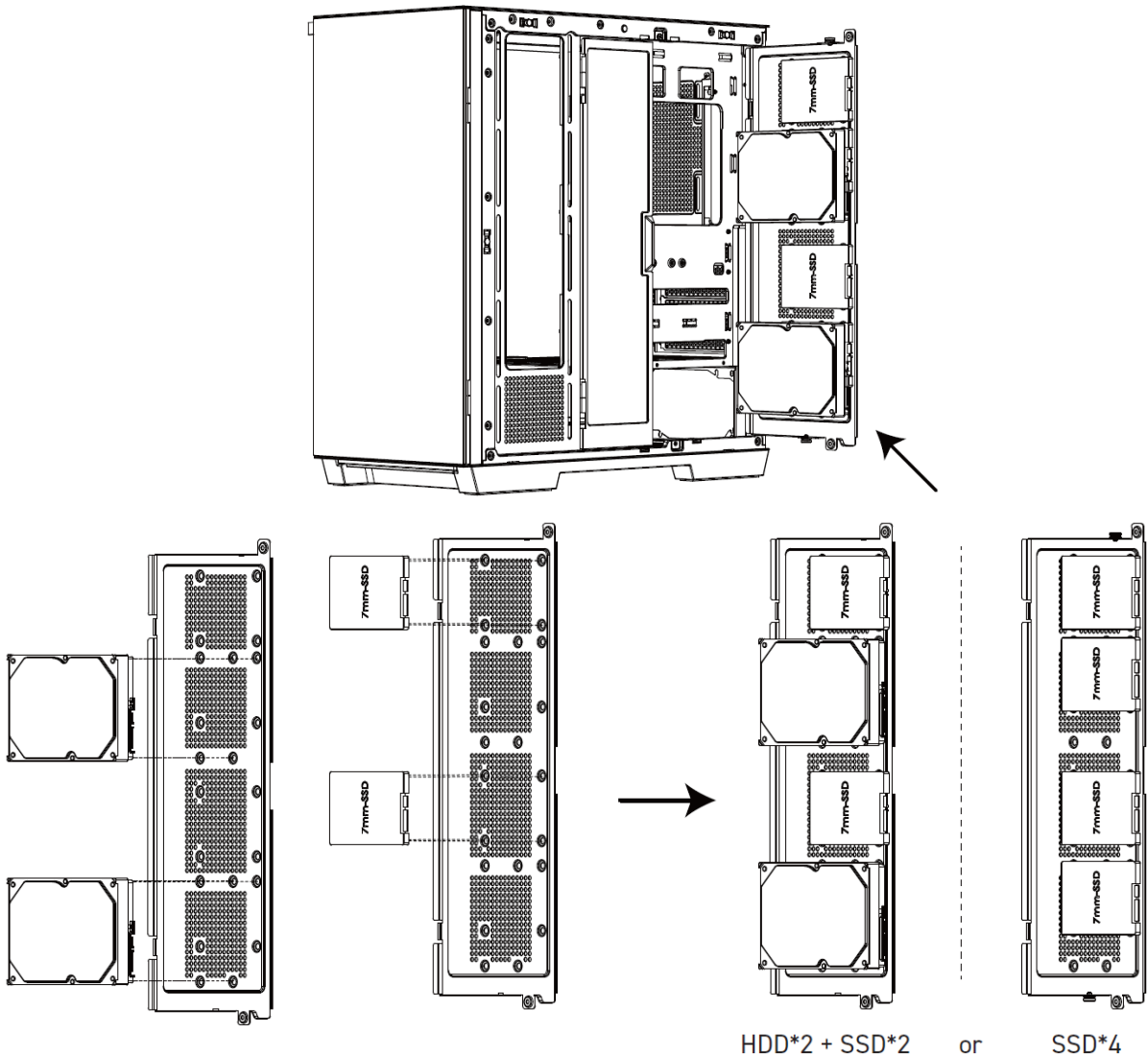

Vis #6-32 5mm

4

Disque dur  
3,5"



Vis M3 5mm

20

Carte mère /  
SSD

## 6. Installez la carte VGA

Retirez la cloison marquée sur l'image, assurez-vous que la carte VGA est alignée avec la fente de la carte mère, puis fixez la carte VGA et le boîtier avec la vis "#6-32 6mm".

Un support de carte VGA est fourni, qui peut être ajusté en fonction de l'emplacement de la carte VGA.

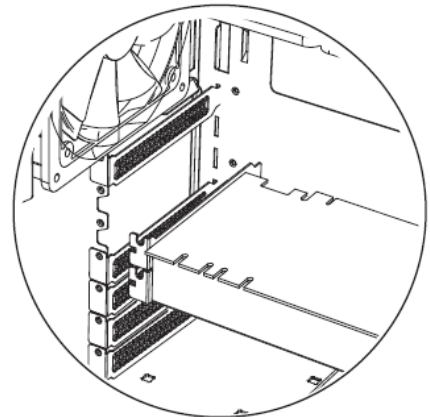
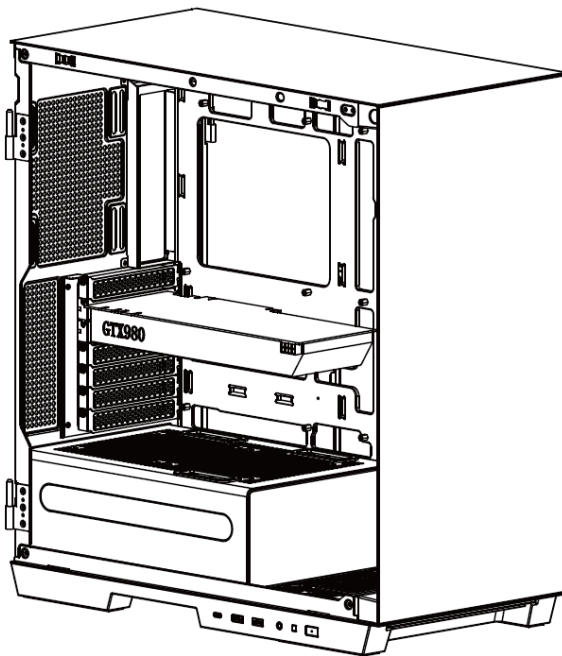

Vis #6-32 6mm

6

PSU / Carte  
PCIe

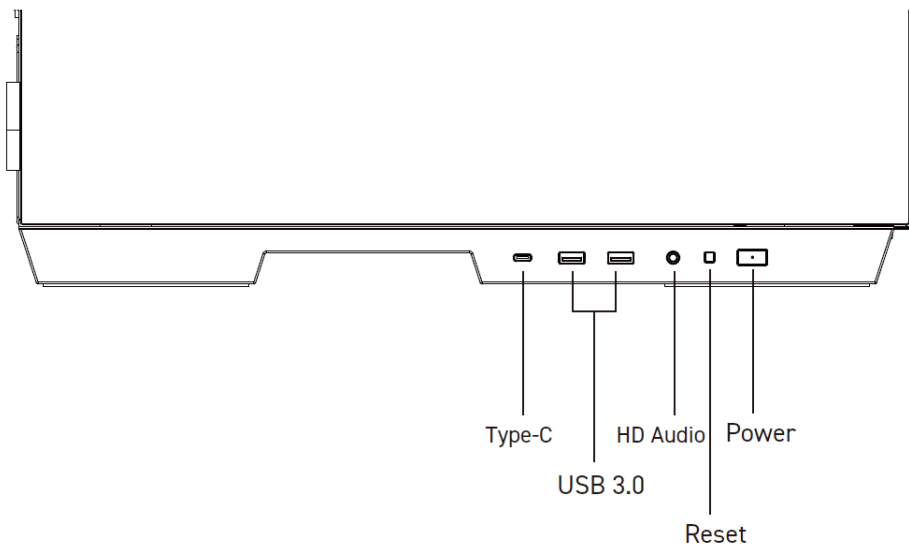

## Connexions

Connecteur audio HD du boîtier

Connecteur USB du boîtier

Connecteur USB 3.0 du boîtier

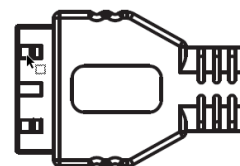

Connecteur audio carte mère

Connecteur USB carte mère

Connecteur USB 3.0 carte mère

PORT1L	■	AUD GND
PORT1R	■	PRESENSE#
PORT2R	■	SENSE1_RETURN
SENSE_SEND	■	NO PIN
PORT2L	■	SENSE_RETURN

VCC	■	VCC
D-	■	D-
D+	■	D+
GND	■	GND
	■	NC

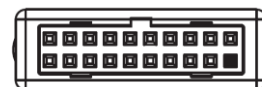

Connecteur Type C du boîtier

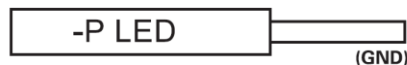
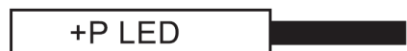

Connecteur Type C carte mère



## Sicherheitsanweisungen

- Die Verwendung des PC-Gehäuses ohne ausreichende Belüftung kann zu Überhitzung führen.
- Stellen Sie sicher, dass der Luftstrom nicht behindert wird. Blockieren Sie niemals die Lüftungsöffnungen.
- Platzieren Sie das PC-Gehäuse nur in einer Umgebung mit ausreichender Luftzirkulation.
- Vermeiden Sie es, das Gehäuse Flüssigkeiten oder Feuchtigkeit auszusetzen.
- Flüssigkeiten können zu einem elektrischen Defekt führen und das Risiko von Feuer oder Stromschlag erhöhen.
- Versuchen Sie nicht, interne Komponenten zu reparieren oder zu zerlegen. Nur qualifiziertes Personal sollte das PC-Gehäuse warten.
- Halten Sie Kinder von den Verpackungsmaterialien fern, da diese eine Erstickungsgefahr darstellen.







## Reinigung

- Trennen Sie die Stromversorgung und alle angeschlossenen Peripheriegeräte, bevor Sie das PC-Gehäuse reinigen.
- Verwenden Sie ein weiches, trockenes Tuch, um das Äußere des PCs zu reinigen.
- Vermeiden Sie die Verwendung von aggressiven Flüssigkeiten oder Reinigungsmitteln.
- Stellen Sie sicher, dass keine Flüssigkeit in die Lüftungsöffnungen gelangt, während Sie das Gerät reinigen.

## Entsorgung

- Ihr PC-Gehäuse besteht aus hochwertigen Materialien, die recycelt und wiederverwendet werden können.
- Beachten Sie die örtlichen Vorschriften zur Entsorgung von Elektronikabfällen.
- Befolgen Sie die örtlichen Richtlinien, um die ordnungsgemäße Entsorgung alter elektronischer Produkte sicherzustellen und negative Auswirkungen auf Umwelt und Gesundheit zu vermeiden.



GEGENSTAND	NAME	MENGE	VERWENDUNG
	Kabelbinder	5	Kabelmanagement
	Schraube #6-32 6.5mm	4	Mainboard-Stütze
	Schraube M3 5mm	20	Mainboard / SSD
	Schraube #6-32 6mm	6	PSU / PCIe-Karte
	Schraube #6-32 5mm	4	3,5" Festplatte
	Schraube M3 28mm	8	Lüfterschraube
	Rückseite E/A- Abdeckung	1	

## 1. Demontieren Sie die Seitenwand und die Vorderwand

Bitte entfernen Sie die Seitenwände, bevor Sie die Vorderwand demontieren.

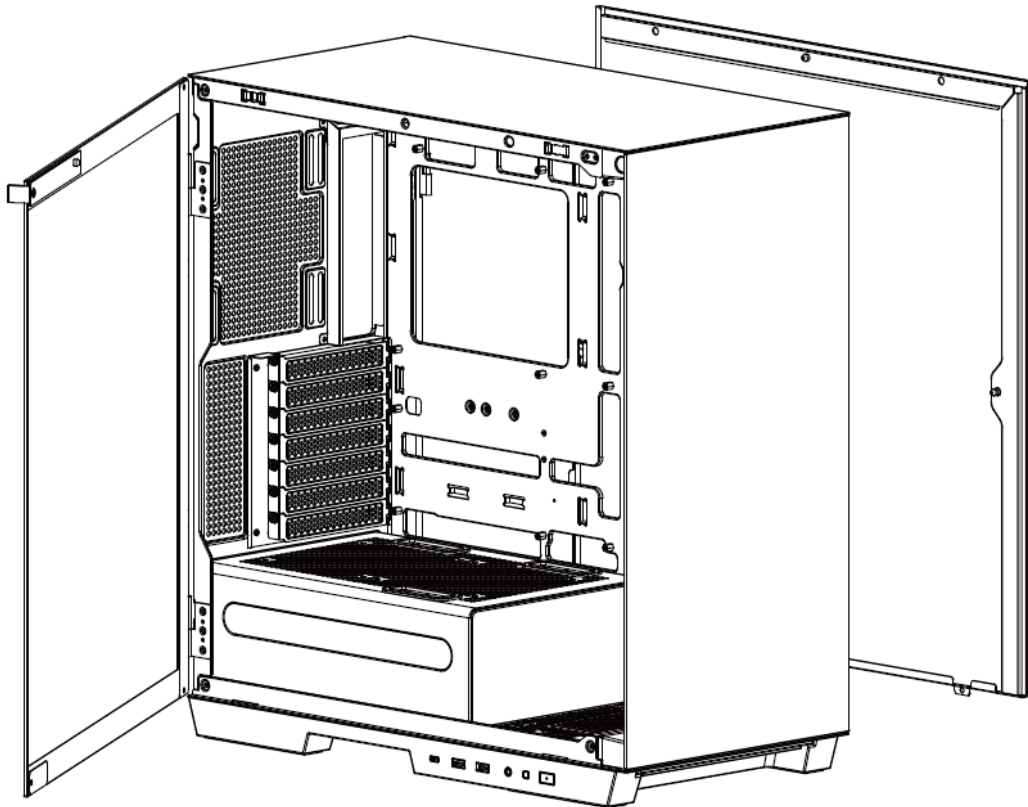

## 2. Installieren Sie das Netzteil

Stellen Sie sicher, dass die Löcher des Netzteils auf die Belüftungsöffnungen des Gehäuses ausgerichtet sind, wenn Sie das Netzteil installieren.

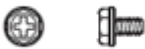
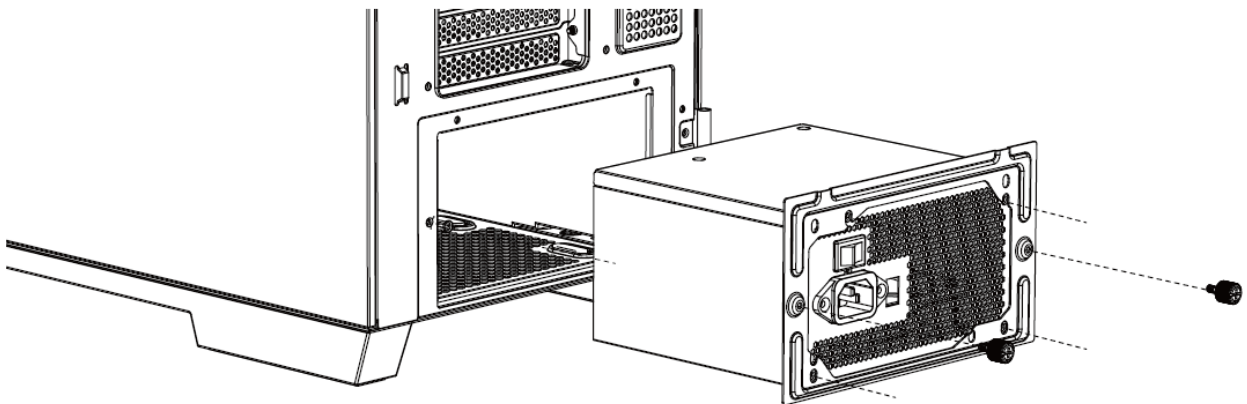

Schraube #6-32  
6mm

6

PSU / PCIe-  
Karte

### 3. Installieren Sie das Mainboard

Stellen Sie sicher, dass das Mainboard auf den Kupferzylinder ausgerichtet ist, und befestigen Sie das Mainboard mit der Schraube „M3 5mm“.

Hinweis: Wenn der Kupferpfiler des Gehäuses abfällt, befestigen Sie ihn mit der Schraube „#6-32 6,5mm“ am Kupferzylinder.

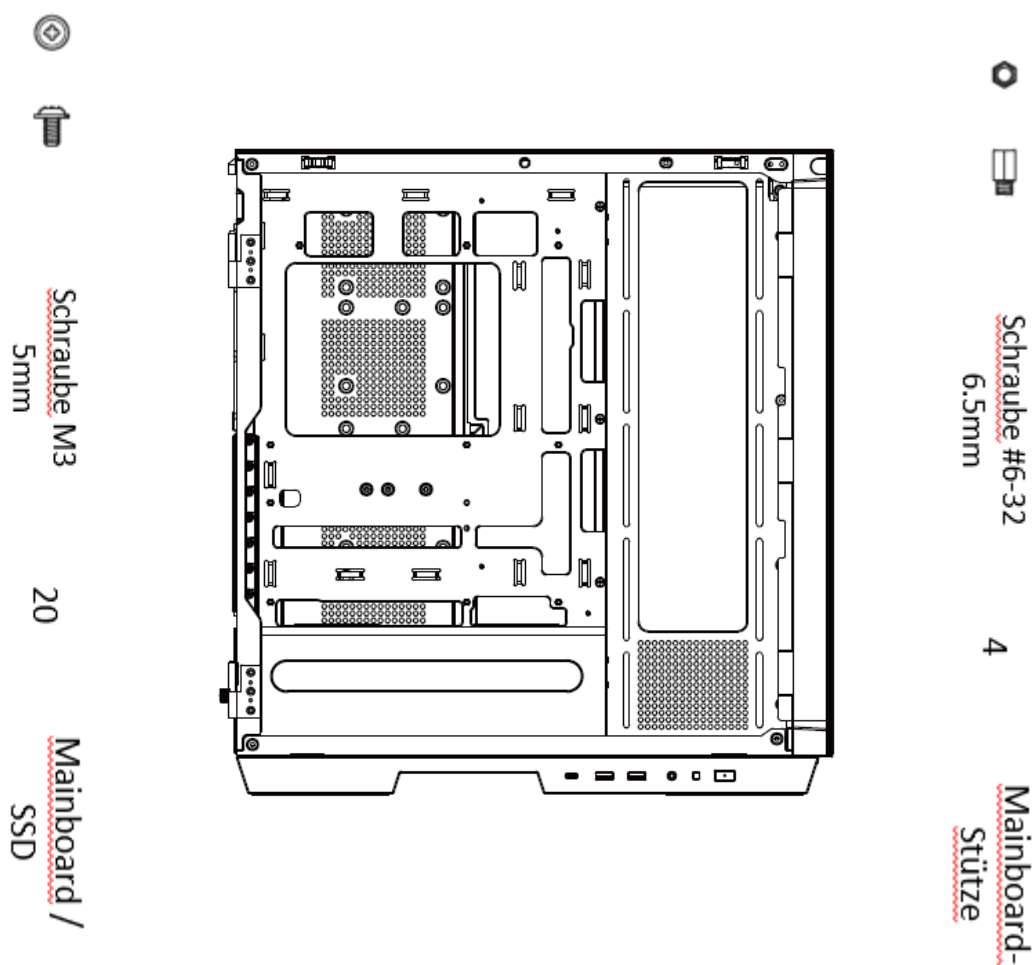

## 4. Installieren Sie den Lüfter und den Radiator

- Oben: 140mm x 2 oder 120mm x 3 (max.)
- Hinten: 140mm x 1 (max.)
- PSU: 120mm x 2 (max.)
- MB: 120mm x 3 (max.)
- Unten: 120mm x 1 (max.)

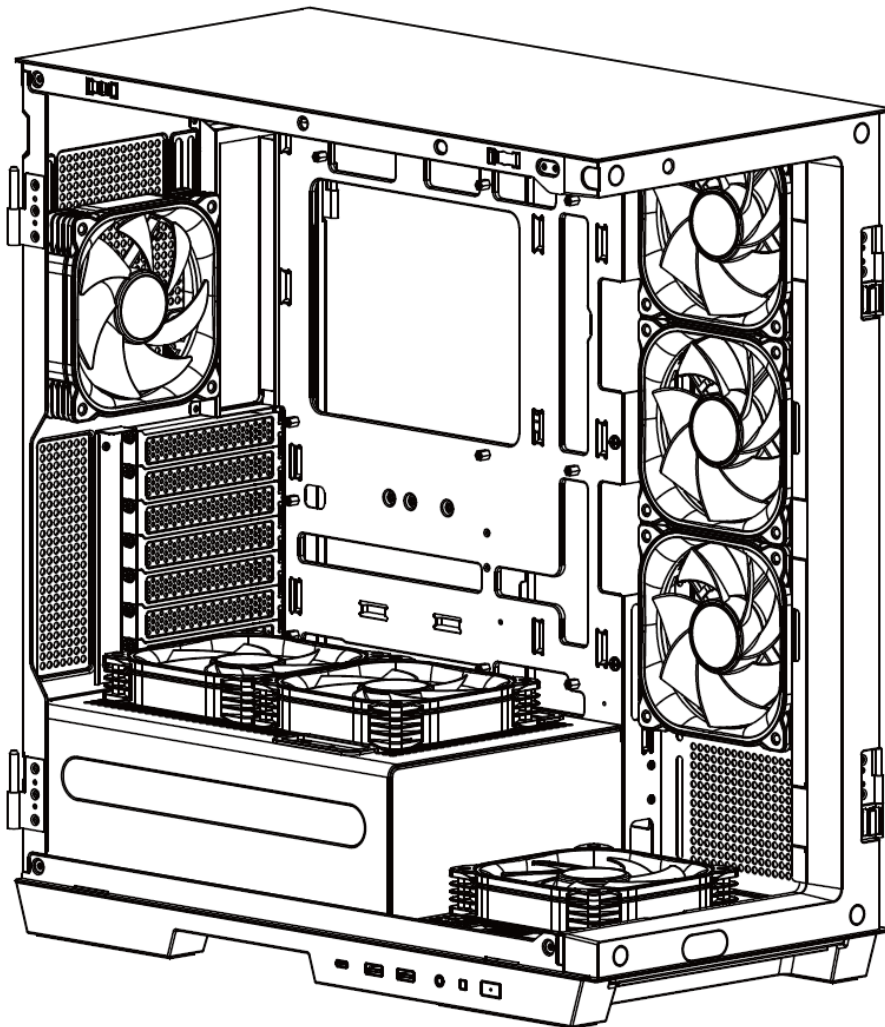

## 5. Installieren Sie die SSD & HDD

Festplattengehäuse für SSD und HDD; Schrauben Sie das Festplattengehäuse ab und installieren Sie die HDD mit den Schrauben.

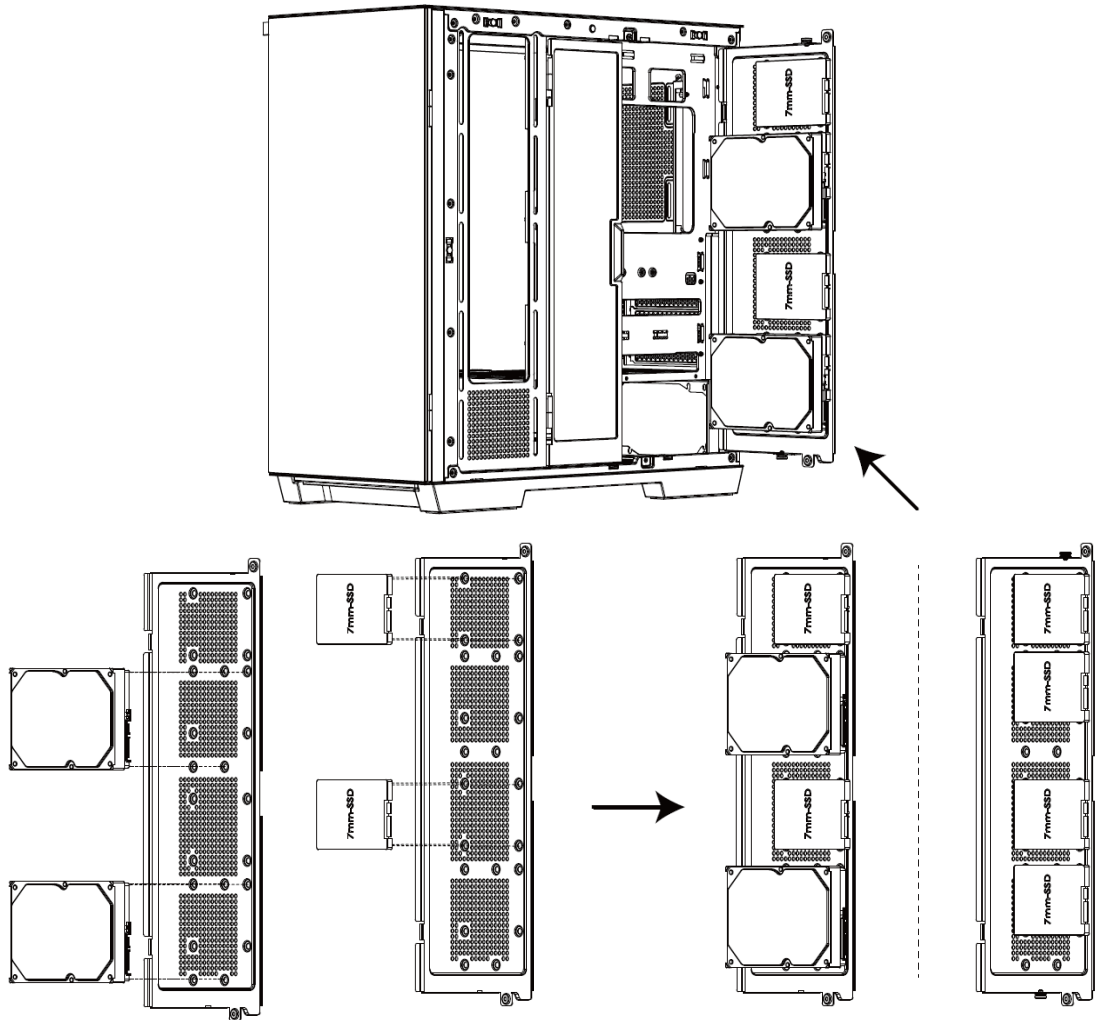

HDD\*2 + SSD\*2 or SSD\*4



Schraube M3  
5mm

20

Mainboard /  
SSD



Schraube #6-32  
5mm

4

3,5" Festplatte

## 6. Installieren Sie die VGA

Entfernen Sie die in der Abbildung markierte Blende, stellen Sie sicher, dass die VGA-Karte auf den Mainboard-Slot ausgerichtet ist, und befestigen Sie dann die VGA-Karte und das Gehäuse mit der Schraube „#6-32 6mm“.

Der VGA-Kartenhalter ist ausgestattet und kann je nach Position der VGA-Karte angepasst werden.

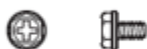
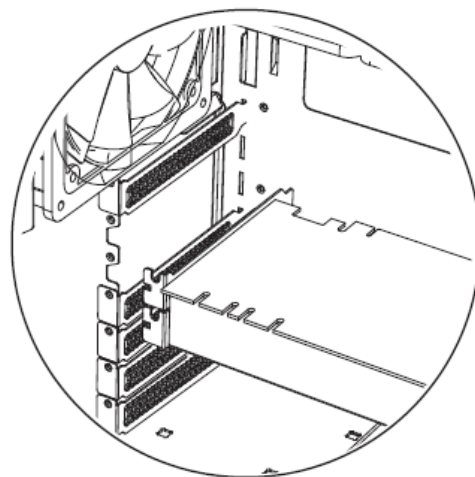
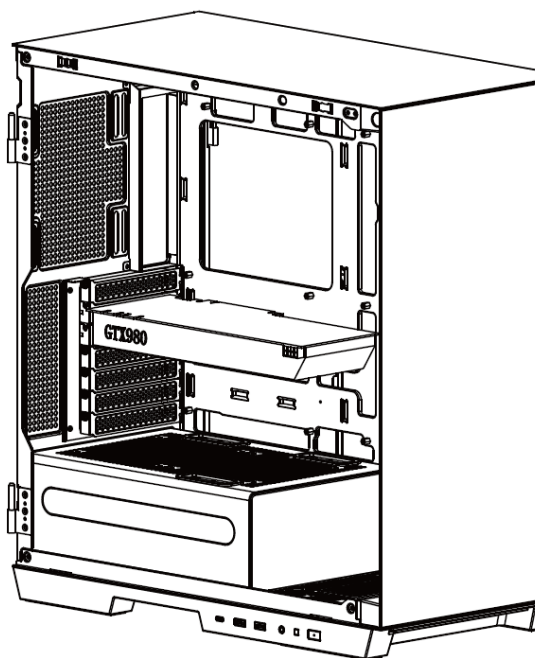

Schraube #6-32  
6mm

6

PSU / PCIe-  
Karte

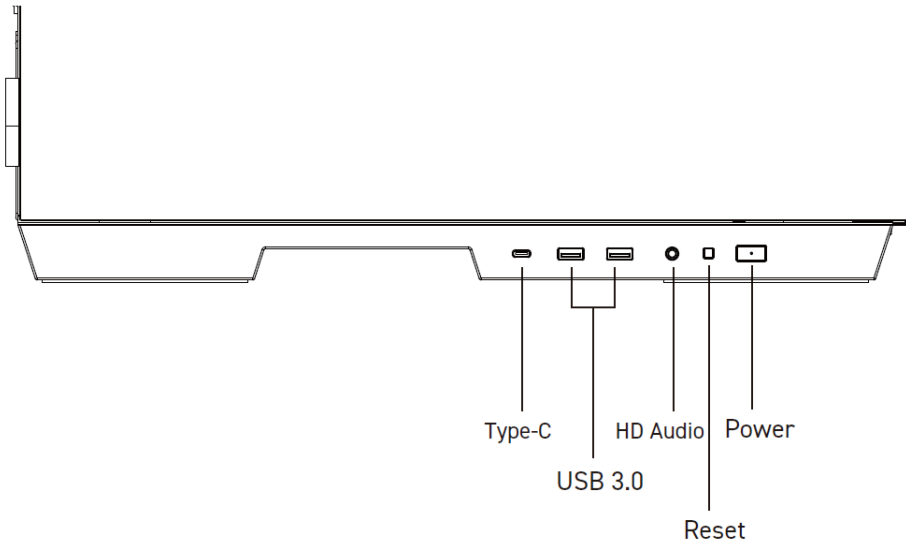

## Anschlüsse

HD-Audio-Anschluss Gehäuses

USB-Anschluss Gehäuses

USB 3.0-Anschluss Gehäuses

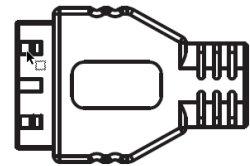
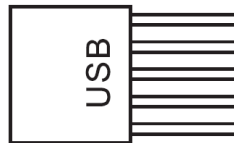

Audio-Anschluss Mainboards

USB-Anschluss Mainboards

USB 3.0-Anschluss Mainboards

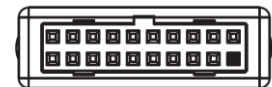
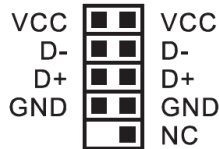

Typ-C-Anschluss Gehäuses

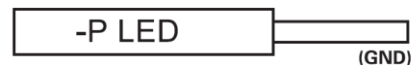
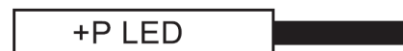

Typ-C-Anschluss Mainboards



## Istruzioni di sicurezza

- L'utilizzo del case del PC senza un'adeguata ventilazione può causare surriscaldamento.
- Assicurarsi che il flusso d'aria non sia ostruito.
- Non bloccare mai le aperture di ventilazione.
- Posizionare il case del PC solo in un ambiente con ampia circolazione d'aria.
- Evitare di esporre il case a liquidi o umidità. I liquidi possono causare guasti elettrici e aumentare il rischio di incendi o scosse elettriche.
- Non tentare di riparare o smontare i componenti interni.
- Solo personale qualificato deve intervenire sul case del PC.
- Tenere i bambini lontani dai materiali di imballaggio poiché presentano un rischio di soffocamento.









## Pulizia

- Scollegare l'alimentazione e tutte le periferiche collegate prima di pulire il case del PC.
- Utilizzare un panno morbido e asciutto per pulire l'esterno del PC.
- Evitare l'uso di liquidi corrosivi o detergenti.
- Assicurarsi che nessun liquido entri nelle aperture di ventilazione durante la pulizia.

## Smaltimento

- Il case del PC è realizzato con materiali di alta qualità che possono essere riciclati e riutilizzati.
- Essere a conoscenza delle normative locali per lo smaltimento dei rifiuti elettronici.
- Seguire le linee guida locali per garantire il corretto smaltimento dei vecchi prodotti elettronici, prevenendo impatti negativi sull'ambiente e sulla salute.

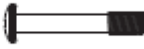

ARTICOLO	NOME	QUANTITÀ	USO
	Fascette per cavi	5	Gestione dei cavi
	Vite #6-32 6.5mm	4	Supporto della scheda madre
	Vite M3 5mm	20	Scheda madre / SSD
	Vite #6-32 6mm	6	PSU / Scheda PCIe
	Vite #6-32 5mm	4	HDD da 3,5"
 	Vite M3 28mm	8	Vite della ventola
	Copertura posteriore I/O	1	

## 1. Smontare il pannello laterale e il pannello frontale

Si prega di rimuovere i pannelli laterali prima di smontare il pannello frontale.

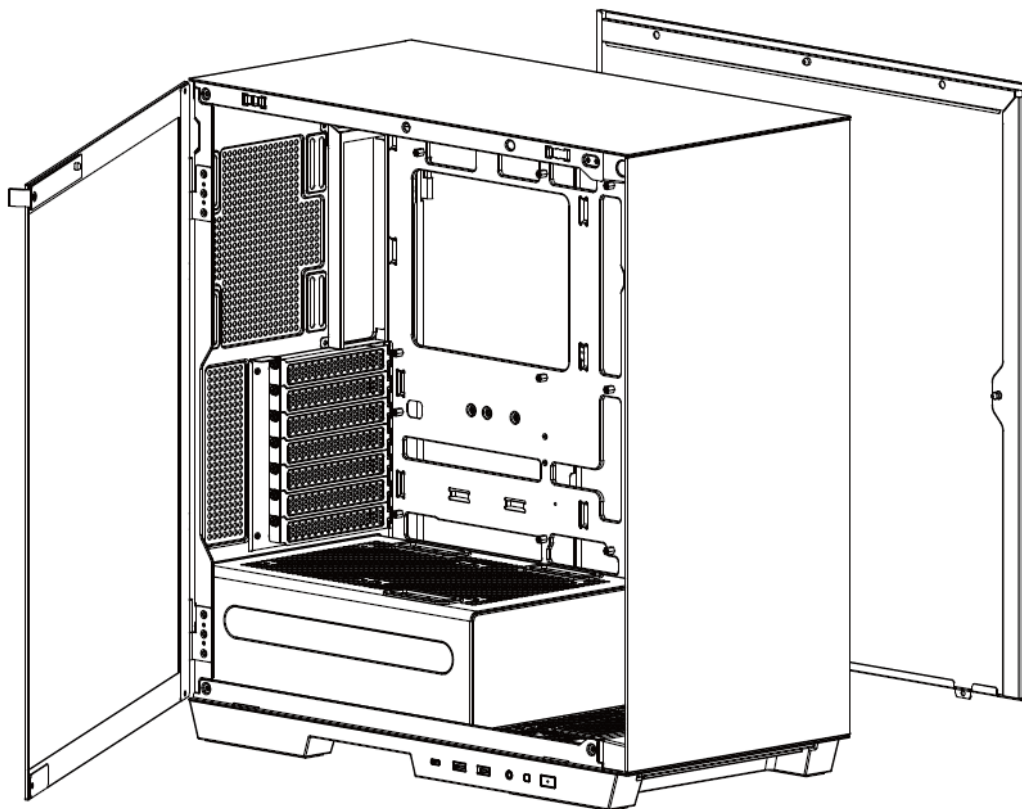

## 2. Installare l'alimentatore

Assicurarsi che i fori dell'alimentatore siano allineati con le griglie di raffreddamento del case durante l'installazione.

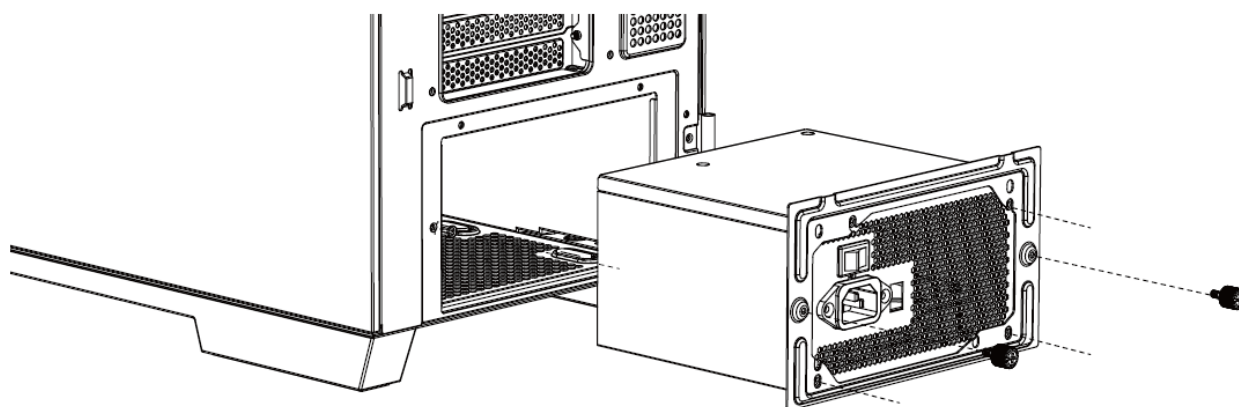

Vite #6-32 6mm

6

PSU / Scheda  
PCIe

### 3. Installare la scheda madre

Assicurarsi che la scheda madre sia allineata con il cilindro di rame e fissare la scheda madre con la vite "M3 5mm".

Nota: se il pilastro di rame del case si stacca, fissarlo con la vite "M6-32 6,5mm" nel cilindro di rame.

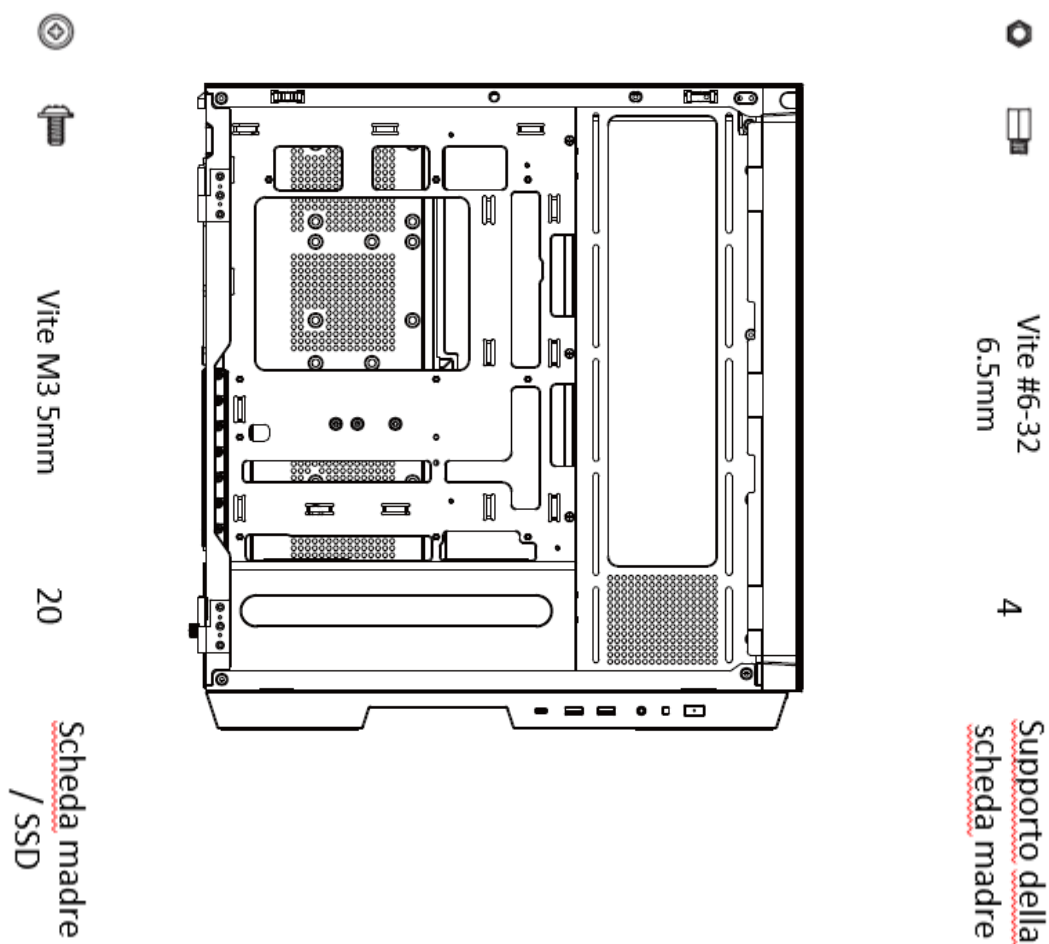

## 4. Installare ventola e radiatore

- Parte superiore: 140mm x 2 o 120mm x 3 (max.)
- Parte posteriore: 140mm x 1 (max.)
- PSU: 120mm x 2 (max.)
- MB: 120mm x 3 (max.)
- Parte inferiore: 120mm x 1 (max.)

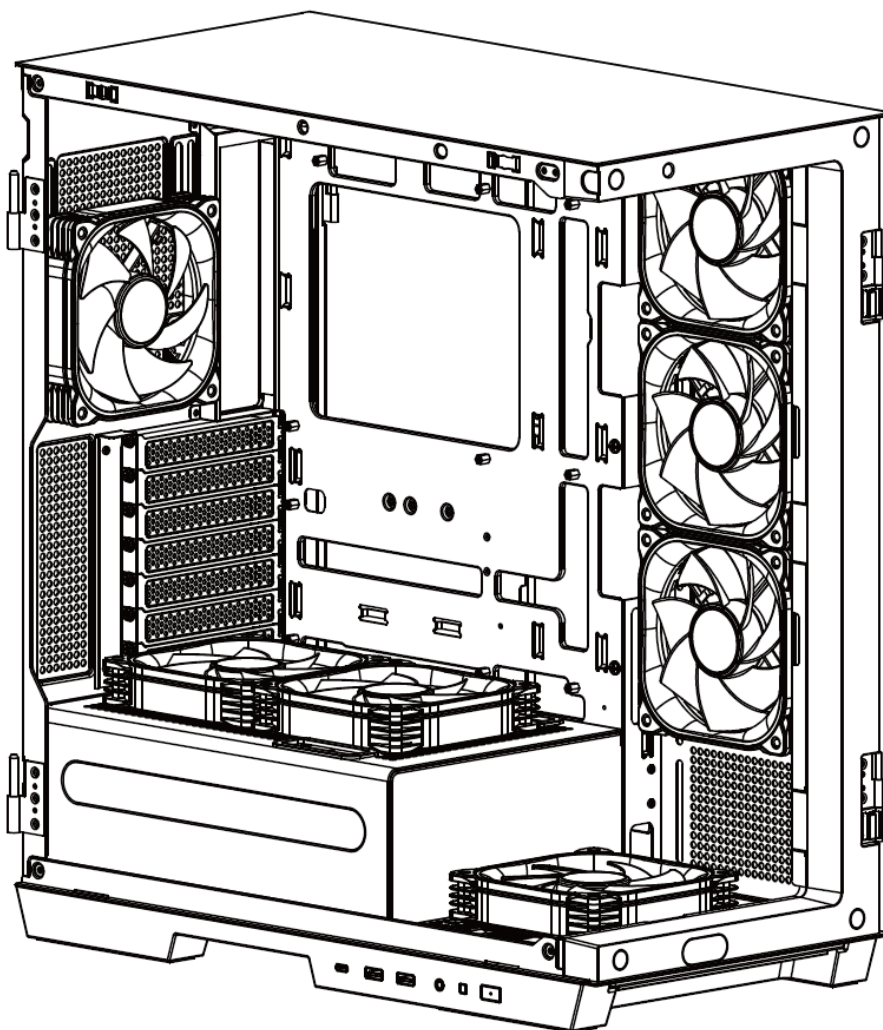

## 5. Installare SSD & HDD

Alloggiamento per dischi rigidi per SSD e HDD; svitare l'alloggiamento del disco rigido e installare l'HDD con le viti.

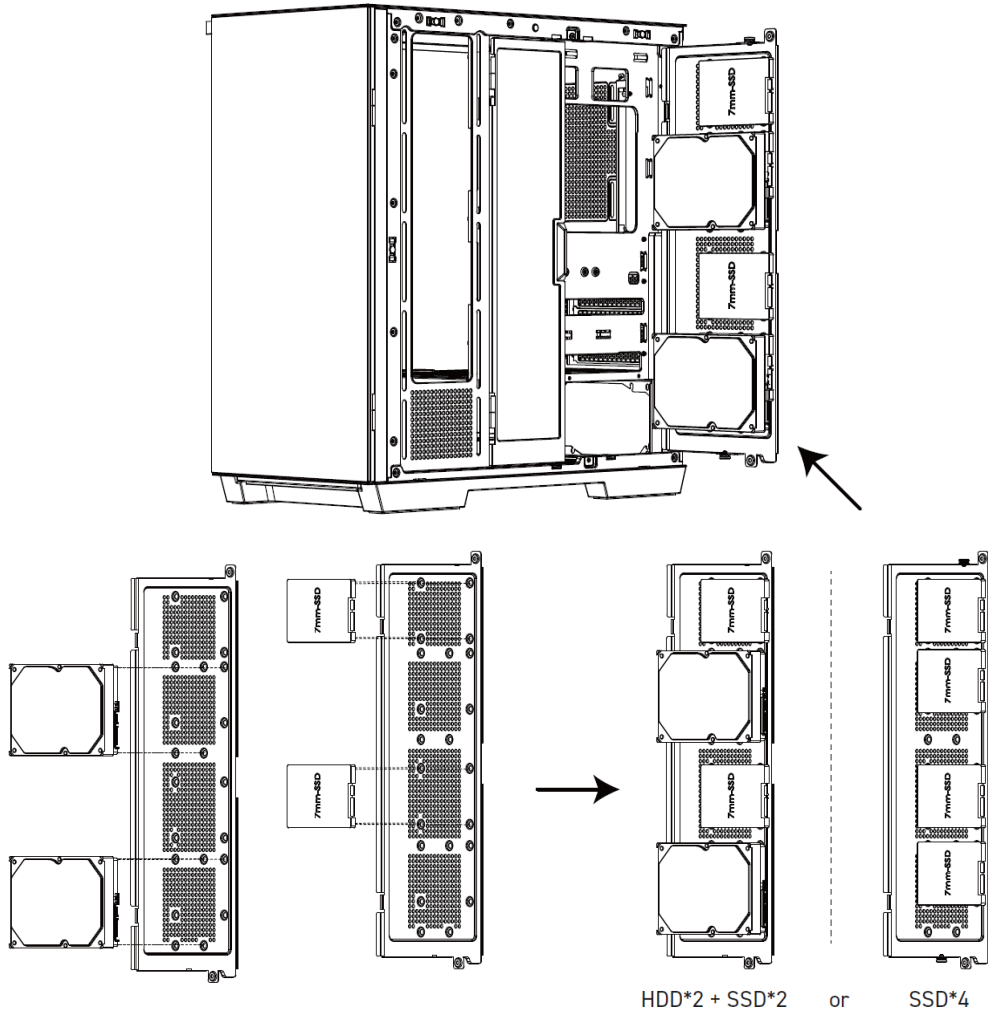

HDD\*2 + SSD\*2 or SSD\*4



Vite M3 5mm

20

Scheda madre  
/ SSD



Vite #6-32 5mm

4

HDD da 3,5"

## 6. Installare la VGA

Rimuovere la staffa segnata nell'immagine, assicurarsi che la scheda VGA sia allineata con lo slot della scheda madre e quindi fissare la scheda VGA e il case con la vite "#6-32 6mm".

Il supporto per la scheda VGA è fornito e può essere regolato in base alla posizione della scheda VGA.

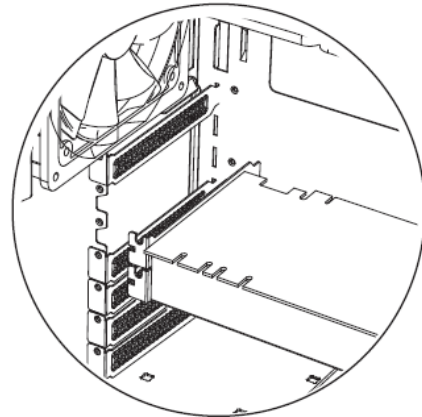
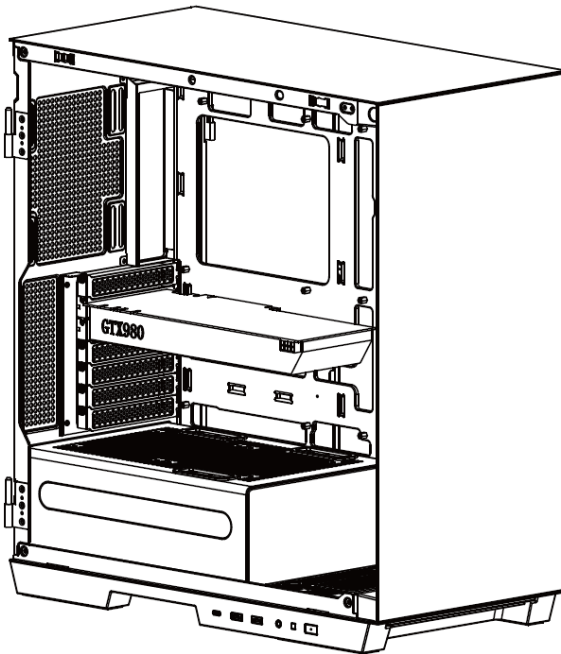

Vite #6-32 6mm

6

PSU / Scheda  
PCIe

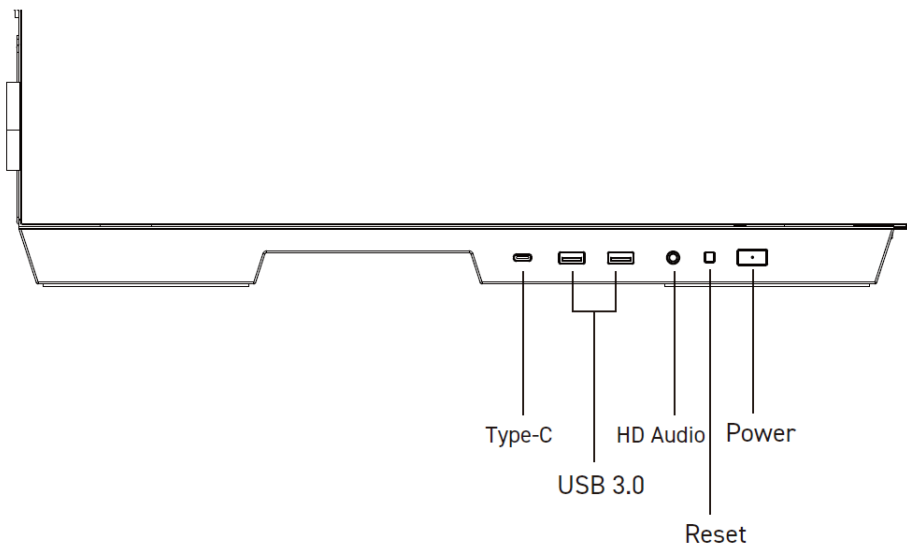

## Connessioni

Connettore audio HD del case

Connettore USB del case

Connettore USB 3.0 del case

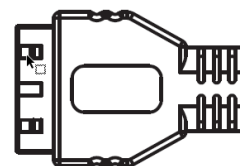

Connettore audio scheda madre

Connettore USB scheda madre

Connettore USB 3.0 della scheda madre

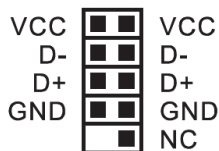

Connettore Type C del case



Connettore Type C scheda madre

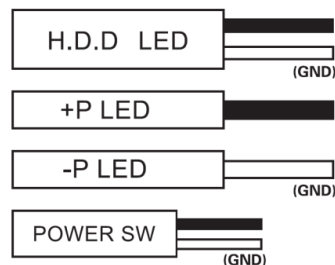

## Instruções de Segurança

- O uso do gabinete do PC sem a ventilação adequada pode levar ao superaquecimento.
- Certifique-se de que o fluxo de ar não esteja obstruído.
- Nunca bloqueie nenhuma abertura de ventilação.
- Coloque o gabinete do PC apenas em um ambiente com ampla circulação de ar. Evite expor o gabinete a líquidos ou umidade.
- Líquidos podem causar falhas elétricas e aumentar o risco de incêndio ou choque elétrico.
- Não tente reparar ou desmontar os componentes internos.
- Apenas pessoal qualificado deve fazer a manutenção do gabinete do PC. Mantenha as crianças longe dos materiais de embalagem, pois representam um risco de asfixia.







## Limpeza

- Desconecte a fonte de alimentação e quaisquer periféricos conectados antes de limpar o gabinete do PC.
- Use um pano macio e seco para limpar o exterior do PC. Evite o uso de líquidos corrosivos ou produtos de limpeza.
- Certifique-se de que nenhum líquido entre nas aberturas de ventilação durante a limpeza.

## Descarte

- Seu gabinete de PC é feito de materiais de alta qualidade que podem ser reciclados e reutilizados.
- Fique atento às regulamentações locais sobre o descarte de resíduos eletrônicos.
- Siga as diretrizes locais para garantir o descarte adequado de produtos eletrônicos antigos, prevenindo impactos negativos no meio ambiente e na saúde.



ITEM	NOME	QUANTIDADE	USO
	Amarras de cabos	5	Gerenciamento de cabos
	Parafuso #6-32 6.5mm	4	Pino da placa-mãe
	Parafuso M3 5mm	20	Placa-mãe / SSD
	Parafuso #6-32 6mm	6	PSU / Placa PCIe
	Parafuso #6-32 5mm	4	HDD de 3,5"
	Parafuso M3 28mm	8	Parafuso do ventilador
	Tampa traseira I/O	1	

## 1. Desmonte o painel lateral e o painel frontal

Por favor, remova os painéis laterais antes de desmontar o painel frontal.

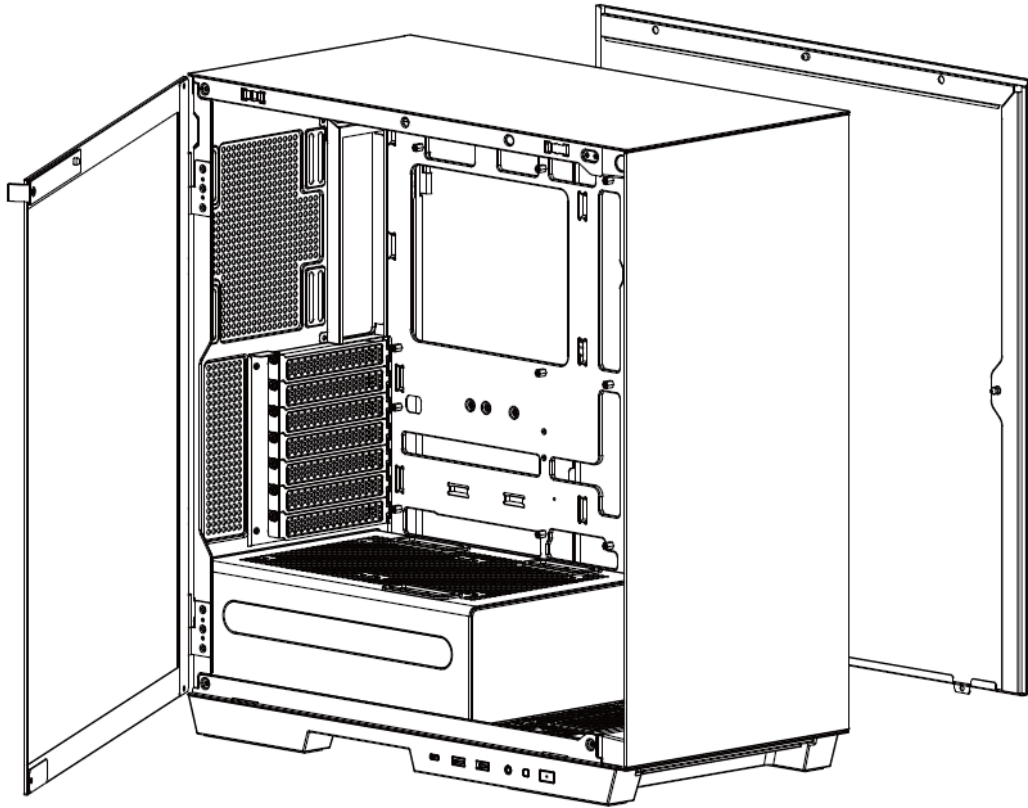

## 2. Instale a fonte de alimentação

Certifique-se de que os orifícios da fonte de alimentação estejam alinhados com as aberturas de ventilação do gabinete ao instalar a fonte de alimentação.

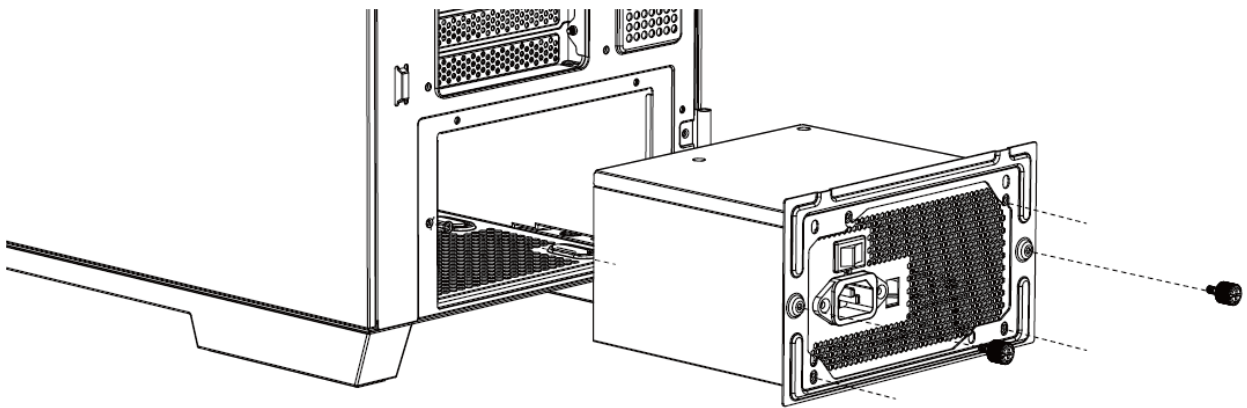

Parafuso #6-32  
6mm

6

PSU / Placa  
PCIe

### 3. Instale a placa-mãe

Certifique-se de que a placa-mãe esteja alinhada com o cilindro de cobre e fixe a placa-mãe com o parafuso "M3 5mm".

Nota: Se o pilar de cobre do gabinete se soltar, fixe-o com o parafuso "#6-32 6,5mm" no cilindro de cobre.

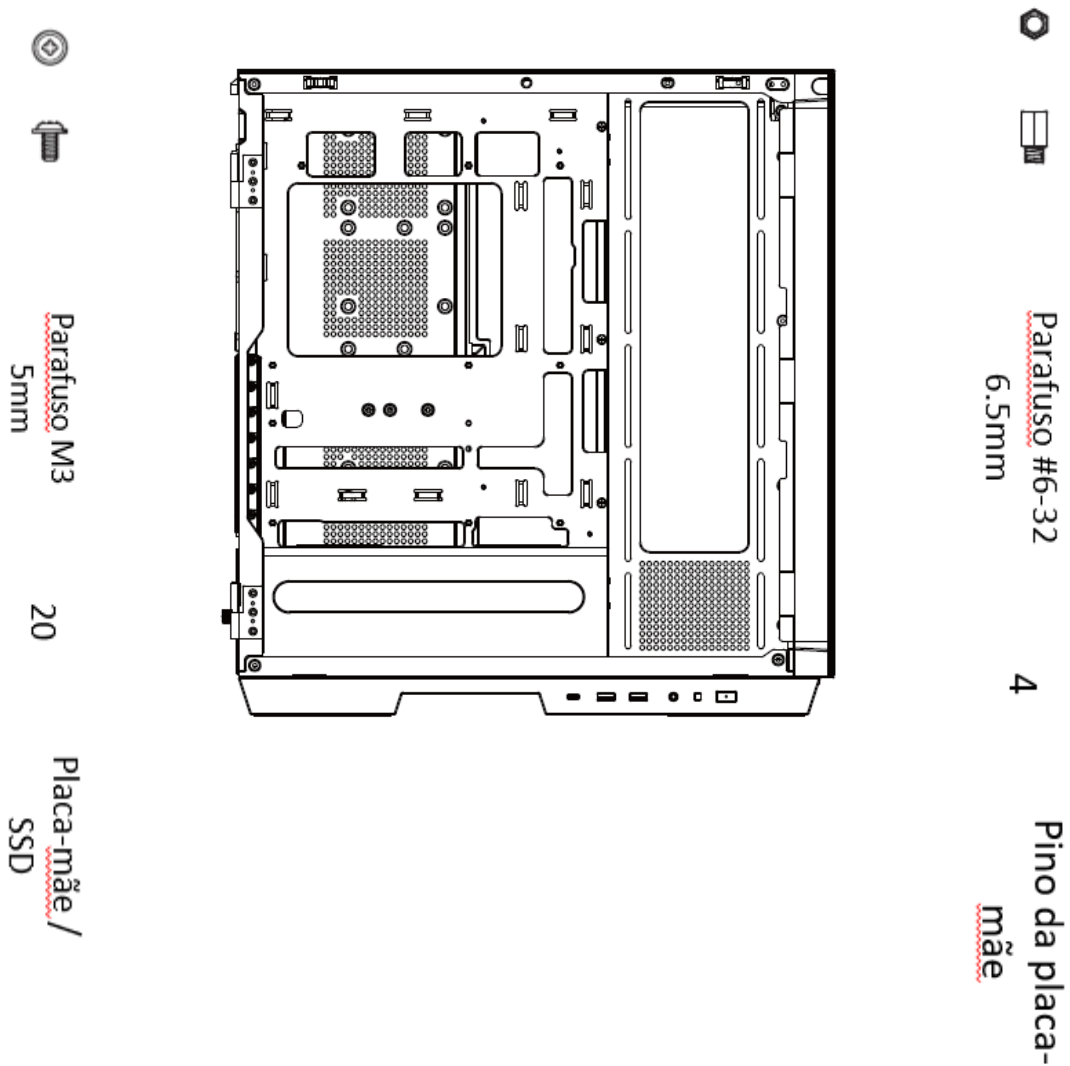

## 4. Instale o ventilador e o radiador

- Parte superior: 140mm x 2 ou 120mm x 3 (máx.)
- Parte traseira: 140mm x 1 (máx.)
- PSU: 120mm x 2 (máx.)
- MB: 120mm x 3 (máx.)
- Parte inferior: 120mm x 1 (máx.)

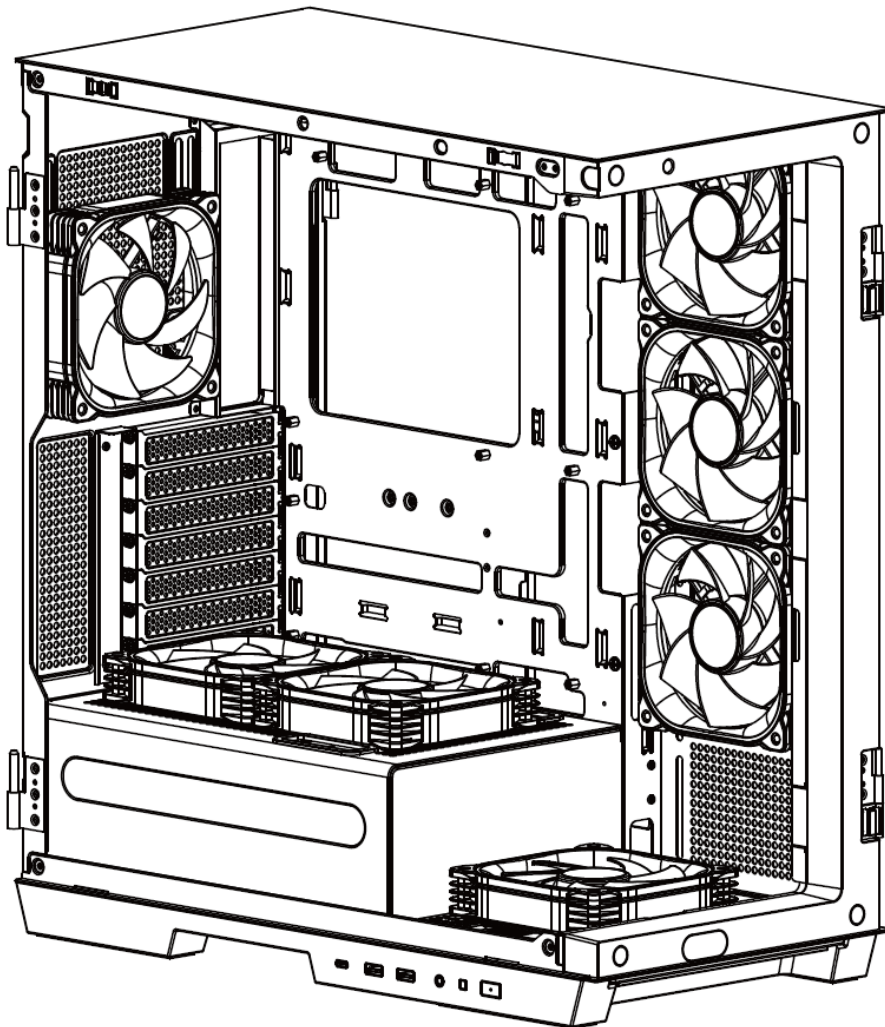

## 5. Instale o SSD & HDD

Compartimento de disco rígido para SSD e HDD; Desaparafuse o compartimento do disco rígido e instale o HDD com os parafusos.

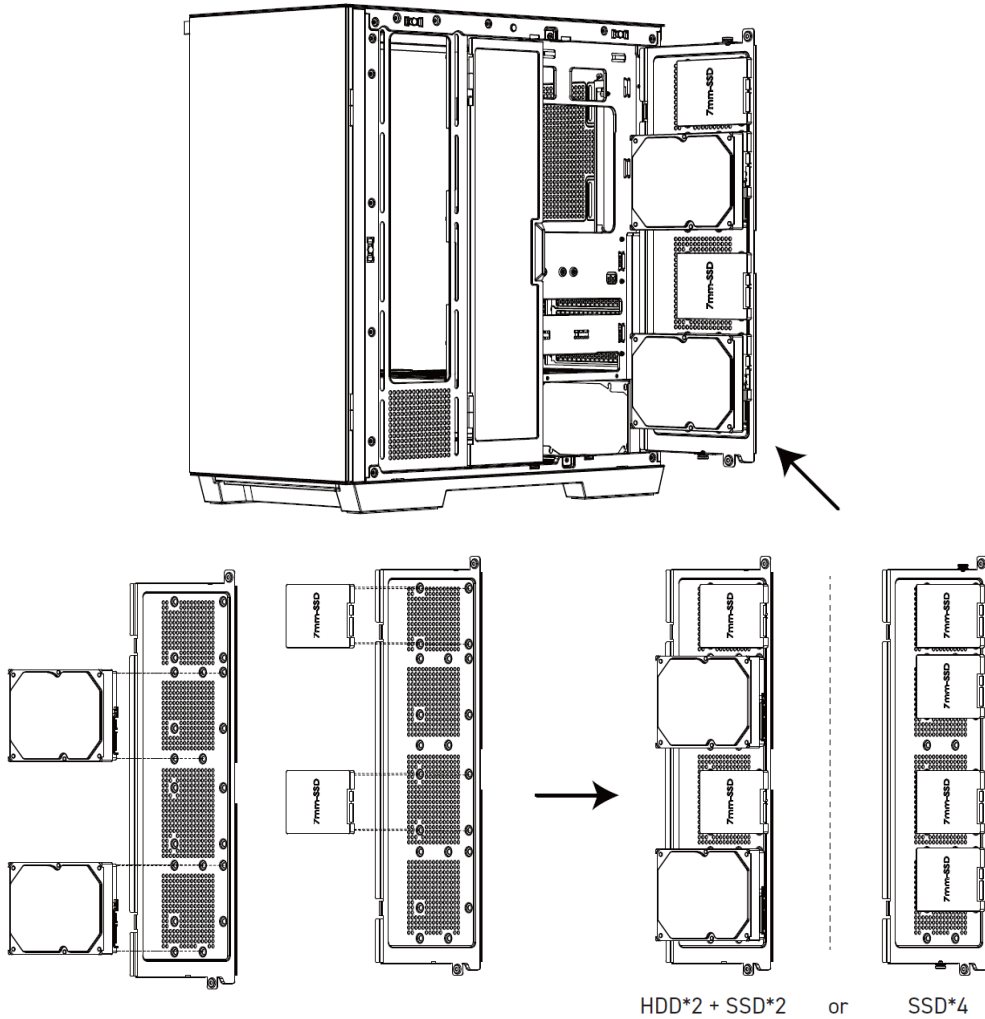

HDD\*2 + SSD\*2 or SSD\*4



Parafuso M3  
5mm

20

Placa-mãe /  
SSD



Parafuso #6-32  
5mm

4

HDD de 3,5"

## 6. Instale a VGA

Remova a tampa marcada na imagem, certifique-se de que a placa VGA esteja alinhada com o slot da placa-mãe e, em seguida, fixe a placa VGA e o gabinete com o parafuso "#6-32 6mm".

O suporte da placa VGA está equipado e pode ser ajustado de acordo com a localização da placa VGA.

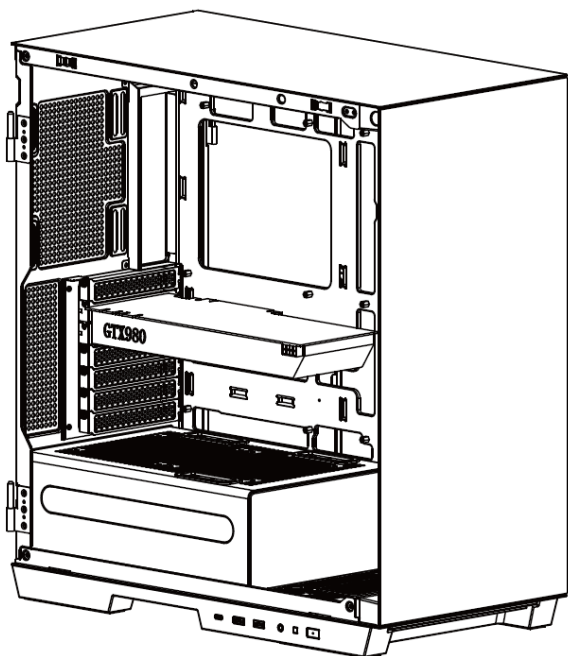

Parafuso #6-32  
6mm

6

PSU / Placa  
PCIe

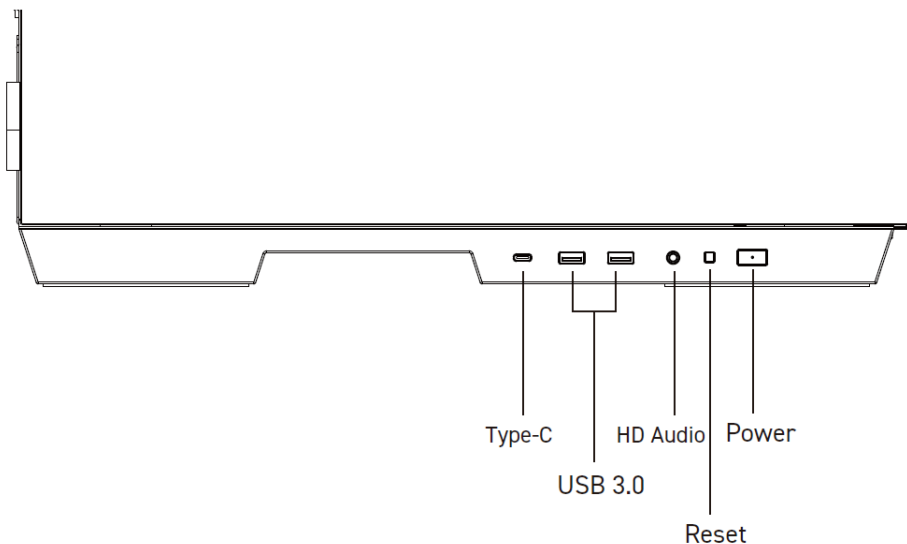

## Conexões

Conector de Áudio HD gabinete

Conector USB do gabinete

Conector USB 3.0 do gabinete

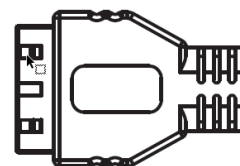

Conector de Áudio placa-mãe

Conector USB da placa-mãe

Conector USB 3.0 da placa-mãe

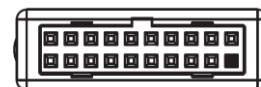
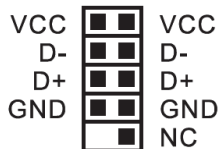

Conector Tipo C do gabinete



Conector Tipo C da placa-mãe

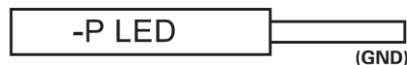
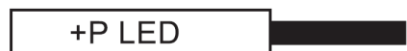

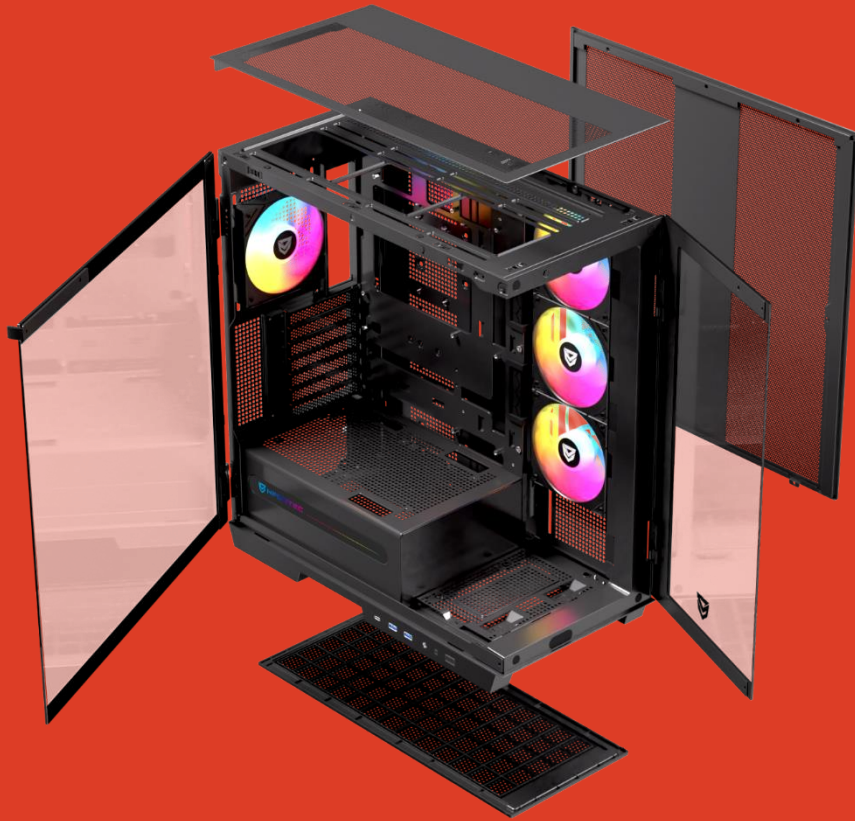

MORE INFORMATION AT  
[nfortec.com](http://nfortec.com)

NEW ALTERNATIVE TECHNOLOGIES, S.L.U.  
Avda de Suiza, 9 P.I. Las Salinas 30840  
Alhama de Murcia SPAIN