

▶ BEK435220M

- EN **User Manual**
Oven
- FR **Notice d'utilisation**
Four
- DE **Benutzerinformation**
Backofen
- IT **Istruzioni per l'uso**
Forno
- ES **Manual de instrucciones**
Horno

USER MANUAL



AEG

FOR PERFECT RESULTS

Thank you for choosing this AEG product. We have created it to give you impeccable performance for many years, with innovative technologies that help make life simpler – features you might not find on ordinary appliances. Please spend a few minutes reading to get the very best from it.

Visit our website to:



Get usage advice, brochures, trouble shooter, service and repair information:
www.aeg.com/support



Register your product for better service:
www.registeraeg.com



Buy Accessories, Consumables and Original spare parts for your appliance:
www.aeg.com/shop

CUSTOMER CARE AND SERVICE

Always use original spare parts.

When contacting our Authorised Service Centre, ensure that you have the following data available: Model, PNC, Serial Number.

The information can be found on the rating plate.

 Warning / Caution-Safety information

 General information and tips

 Environmental information

Subject to change without notice.

CONTENTS

1. SAFETY INFORMATION.....	2
2. SAFETY INSTRUCTIONS.....	4
3. PRODUCT DESCRIPTION.....	6
4. CONTROL PANEL.....	7
5. BEFORE FIRST USE.....	8
6. DAILY USE.....	8
7. CLOCK FUNCTIONS.....	9
8. USING THE ACCESSORIES.....	10
9. ADDITIONAL FUNCTIONS.....	11
10. HINTS AND TIPS.....	11
11. CARE AND CLEANING.....	23
12. TROUBLESHOOTING.....	25
13. ENERGY EFFICIENCY.....	26

1. SAFETY INFORMATION

Before the installation and use of the appliance, carefully read the supplied instructions. The manufacturer is not responsible

for any injuries or damage that are the result of incorrect installation or usage. Always keep the instructions in a safe and accessible location for future reference.

1.1 Children and vulnerable people safety

- This appliance can be used by children aged from 8 years and above and persons with reduced physical, sensory or mental capabilities or lack of experience and knowledge if they have been given supervision or instruction concerning the use of the appliance in a safe way and understand the hazards involved. Children of less than 8 years of age and persons with very extensive and complex disabilities shall be kept away from the appliance unless continuously supervised.
- Do not let children play with the appliance.
- Keep all packaging away from children and dispose of it appropriately.
- **WARNING:** Keep children and pets away from the appliance when it operates or when it cools down. Accessible parts become hot during use.
- If the appliance has a child safety device, it should be activated.
- Children shall not carry out cleaning and user maintenance of the appliance without supervision.

1.2 General Safety

- Only a qualified person must install this appliance and replace the cable.
- **WARNING:** The appliance and its accessible parts become hot during use. Care should be taken to avoid touching heating elements.
- Always use oven gloves to remove or put in accessories or ovenware.
- Before carrying out any maintenance, disconnect the appliance from the power supply.
- **WARNING:** Ensure that the appliance is switched off before replacing the lamp to avoid the possibility of electric shock.

- Do not use the appliance before installing it in the built-in structure.
- Do not use a steam cleaner to clean the appliance.
- Do not use harsh abrasive cleaners or sharp metal scrapers to clean the glass door since they can scratch the surface, which may result in shattering of the glass.
- If the mains power supply cable is damaged, it must be replaced by the manufacturer, its Authorised Service Centre or similarly qualified persons to avoid an electrical hazard.
- To remove the shelf supports first pull the front of the shelf support and then the rear end away from the side walls. Install the shelf supports in the opposite sequence.

2. SAFETY INSTRUCTIONS

2.1 Installation



WARNING!

Only a qualified person must install this appliance.

- Remove all the packaging.
- Do not install or use a damaged appliance.
- Follow the installation instructions supplied with the appliance.
- Always take care when moving the appliance as it is heavy. Always use safety gloves and enclosed footwear.
- Do not pull the appliance by the handle.
- Install the appliance in a safe and suitable place that meets installation requirements.
- Keep the minimum distance from other appliances and units.
- Before mounting the appliance, check if the oven door opens without restraint.
- The appliance is equipped with an electric cooling system. It must be operated with the electric power supply.
- The built-in unit must meet the stability requirements of DIN 68930.

Cabinet minimum height (Cabinet under the worktop minimum height)	578 (600) mm
-------------------------------------------------------------------------	--------------

Cabinet width	560 mm
---------------	--------

Cabinet depth	550 (550) mm
---------------	--------------

Height of the front of the appliance	594 mm
Height of the back of the appliance	576 mm
Width of the front of the appliance	595 mm
Width of the back of the appliance	559 mm
Depth of the appliance	567 mm
Built in depth of the appliance	546 mm
Depth with open door	1027 mm
Ventilation opening minimum size. Opening placed on the bottom rear side	560 x 20 mm
Mains supply cable length. Cable is placed in the right corner of the back side	1500 mm
Mounting screws	4 x 25 mm

2.2 Electrical connection



WARNING!

Risk of fire and electric shock.

- All electrical connections should be made by a qualified electrician.
- The appliance must be earthed.

- Make sure that the parameters on the rating plate are compatible with the electrical ratings of the mains power supply.
- Always use a correctly installed shockproof socket.
- Do not use multi-plug adapters and extension cables.
- Make sure not to cause damage to the mains plug and to the mains cable. Should the mains cable need to be replaced, this must be carried out by our Authorised Service Centre.
- Do not let mains cables touch or come near the appliance door or the niche below the appliance, especially when it operates or the door is hot.
- The shock protection of live and insulated parts must be fastened in such a way that it cannot be removed without tools.
- Connect the mains plug to the mains socket only at the end of the installation. Make sure that there is access to the mains plug after the installation.
- If the mains socket is loose, do not connect the mains plug.
- Do not pull the mains cable to disconnect the appliance. Always pull the mains plug.
- Use only correct isolation devices: line protecting cut-outs, fuses (screw type fuses removed from the holder), earth leakage trips and contactors.
- The electrical installation must have an isolation device which lets you disconnect the appliance from the mains at all poles. The isolation device must have a contact opening width of minimum 3 mm.
- This appliance is supplied with a main plug and a main cable.

2.3 Use



WARNING!

Risk of injury, burns and electric shock or explosion.

- This appliance is for household use only.
- Do not change the specification of this appliance.
- Make sure that the ventilation openings are not blocked.
- Do not let the appliance stay unattended during operation.
- Deactivate the appliance after each use.

- Be careful when you open the appliance door while the appliance is in operation. Hot air can release.
- Do not operate the appliance with wet hands or when it has contact with water.
- Do not apply pressure on the open door.
- Do not use the appliance as a work surface or as a storage surface.
- Open the appliance door carefully. The use of ingredients with alcohol can cause a mixture of alcohol and air.
- Do not let sparks or open flames to come in contact with the appliance when you open the door.
- Do not put flammable products or items that are wet with flammable products in, near or on the appliance.



WARNING!

Risk of damage to the appliance.

- To prevent damage or discoloration to the enamel:
 - do not put ovenware or other objects in the appliance directly on the bottom.
 - do not put aluminium foil directly on the bottom of cavity of the appliance.
 - do not put water directly into the hot appliance.
 - do not keep moist dishes and food in the appliance after you finish the cooking.
 - be careful when you remove or install the accessories.
- Discoloration of the enamel or stainless steel has no effect on the performance of the appliance.
- Use a deep pan for moist cakes. Fruit juices cause stains that can be permanent.
- This appliance is for cooking purposes only. It must not be used for other purposes, for example room heating.
- Always cook with the oven door closed.
- If the appliance is installed behind a furniture panel (e.g. a door) make sure the door is never closed when the appliance operates. Heat and moisture can build up behind a closed furniture panel and cause subsequent damage to the appliance, the housing unit or the floor. Do not close the furniture panel until the appliance has cooled down completely after use.

2.4 Care and cleaning



WARNING!

Risk of injury, fire, or damage to the appliance.

- Before maintenance, deactivate the appliance and disconnect the mains plug from the mains socket.
- Make sure the appliance is cold. There is the risk that the glass panels can break.
- Replace immediately the door glass panels when they are damaged. Contact the Authorised Service Centre.
- Clean regularly the appliance to prevent the deterioration of the surface material.
- Clean the appliance with a moist soft cloth. Use only neutral detergents. Do not use abrasive products, abrasive cleaning pads, solvents or metal objects.
- If you use an oven spray, follow the safety instructions on its packaging.

2.5 Internal lighting



WARNING!

Risk of electric shock.

- Concerning the lamp(s) inside this product and spare part lamps sold separately:

These lamps are intended to withstand extreme physical conditions in household appliances, such as temperature, vibration, humidity, or are intended to signal information about the operational status of the appliance. They are not intended to be used in other applications and are not suitable for household room illumination.

- Use only lamps with the same specifications.

2.6 Service

- To repair the appliance contact the Authorised Service Centre.
- Use original spare parts only.

2.7 Disposal



WARNING!

Risk of injury or suffocation.

- Disconnect the appliance from the mains supply.
- Cut off the mains electrical cable close to the appliance and dispose of it.
- Remove the door catch to prevent children or pets from becoming trapped in the appliance.

3. PRODUCT DESCRIPTION

3.1 General overview

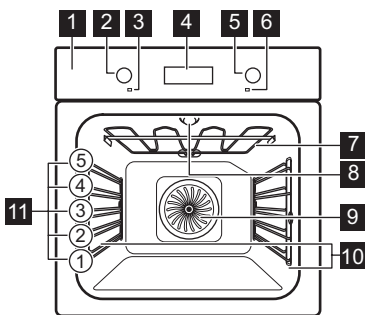

- 1** Control panel
- 2** Knob for the heating functions
- 3** Power lamp / symbol
- 4** Display
- 5** Control knob (for the temperature)
- 6** Temperature indicator / symbol
- 7** Heating element
- 8** Lamp
- 9** Fan
- 10** Shelf support, removable
- 11** Shelf positions

3.2 Accessories

Wire shelf

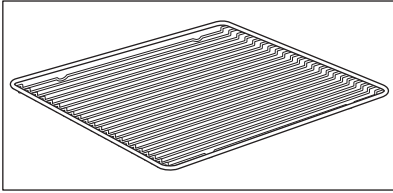

For cookware, cake tins, roasts.

Baking tray

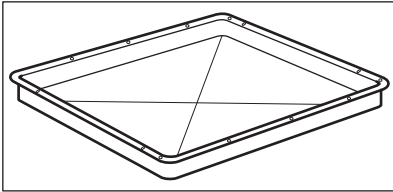

For cakes and biscuits.

Grill- / Roasting pan

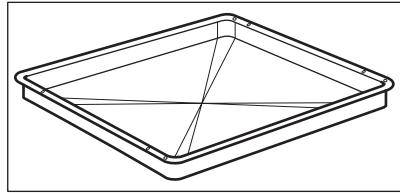

To bake and roast or as a pan to collect fat.

4. CONTROL PANEL

4.1 Retractable knobs

To use the appliance press the knob. The knob comes out.

4.2 Sensor fields / Buttons

—	To set the time.
⌚	To set a clock function.
+	To set the time.

4.3 Display

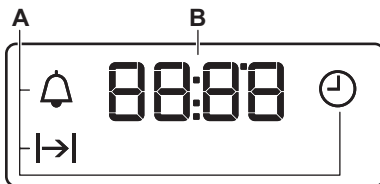

- A. Clock functions
- B. Timer

5. BEFORE FIRST USE



WARNING!

Refer to Safety chapters.

5.1 Before first use

The oven can emit an odour and smoke during preheating. Make sure that the room is ventilated.



Step 1

Set the clock

1. Press:
2. - press to set the hour.
Press:
3. - press to set the minutes. Press:



Step 2

Clean the oven

1. Remove all accessories and removable shelf supports from the oven.
2. Clean the oven and the accessories with a soft cloth, warm water and a mild detergent.



Step 3

Preheat the empty oven

1. Set the maximum temperature for the function:
Time: 1 h.
2. Set the maximum temperature for the function:
Time: 15 min.

Turn off the oven and wait until it is cold. Place the accessories and the removable shelf supports in the oven.

6. DAILY USE



WARNING!

Refer to Safety chapters.

6.1 How to set: Heating function

- Step 1** Turn the knob for the heating functions to select a heating function.
- Step 2** Turn the control knob to select the temperature.
- Step 3** When the cooking ends, turn the knobs to the off position to turn off the oven.

6.2 Heating functions

Heating function	Application
------------------	-------------

0

Off position

The oven is off.

Heating function	Application
------------------	-------------



Light

To turn on the lamp.



True Fan Cooking

To bake on up to three shelf positions at the same time and to dry food.
Set the temperature 20 - 40 °C lower than for Conventional Cooking.







Pizza Function

To bake pizza. To make intensive browning and a crispy bottom.



Conventional Cooking

To bake and roast food on one shelf position.

Heating function	Application
 Bottom Heat	To bake cakes with crispy bottom and to preserve food.
 Defrost	To defrost food (vegetables and fruit). The defrosting time depends on the amount and size of the frozen food.
 Moist Fan Baking	This function is designed to save energy during cooking. When you use this function, the temperature in the cavity may differ from the set temperature. The residual heat is used. The heating power may be reduced. For more information refer to "Daily Use" chapter, Notes on: Moist Fan Baking.
 Grill	To grill thin pieces of food and to toast bread.

Heating function	Application
 Turbo Grilling	To roast large meat joints or poultry with bones on one shelf position. To make gratins and to brown.

 The lamp may turn off automatically at a temperature below 60 °C during some oven functions.

6.3 Notes on: Moist Fan Baking



This function was used to comply with the energy efficiency class and ecodesign requirements according to EU 65/2014 and EU 66/2014. Tests according to EN 60350-1.

The oven door should be closed during cooking so that the function is not interrupted and the oven operates with the highest energy efficiency possible.

For the cooking instructions refer to "Hints and tips" chapter, Moist Fan Baking. For general energy saving recommendations refer to "Energy Efficiency" chapter, Energy Saving.

7. CLOCK FUNCTIONS

7.1 Clock functions

Clock function	Application
 Time of Day	To set, change or check the time of day.
 Duration	To set how long the oven works.
 Minute Minder	To set a countdown. This function has no effect on the operation of the oven. You can set this function at any time, also when the oven is off.



7.2 How to set: Clock functions



How to change: Time of Day

 - flashes when you connect the oven to the electrical supply, when there was a power cut or when the timer is not set.

How to change: Time of Day

Step 1  - press repeatedly.  - starts to flash.





Step 2 ,  - press to set the time.
After approximately 5 sec., the flashing stops and the display shows the time.

 - press repeatedly to change the time of day.  - starts to flash.

How to set: Duration

Step 1 Set an oven function and the temperature.

Step 2  - press repeatedly.  - starts to flash.



Step 3 ,  - press to set the duration.
The display shows: .
 - flashes when the set time ends. The signal sounds and the oven turns off.

Step 4 Press any button to stop the signal.

Step 5 Turn the knobs to the off position.

How to set: Minute Minder

Step 1  - press repeatedly.  - starts to flash.

Step 2 ,  - press to set the time.
The function starts automatically after 5 sec.
When the set time ends, the signal sounds.

Step 3 Press any button to stop the signal.

Step 4 Turn the knobs to the off position.

How to cancel: Clock functions

Step 1  - press repeatedly until the clock function symbol starts to flash.

Step 2 Press and hold: .
The clock function turns off after few seconds.

8. USING THE ACCESSORIES



WARNING!

Refer to Safety chapters.

devices. The high rim around the shelf prevents cookware from slipping of the shelf.

8.1 Inserting accessories

A small indentation at the top increases safety. The indentations are also anti-tip

Wire shelf:

Push the shelf between the guide bars of the shelf support.

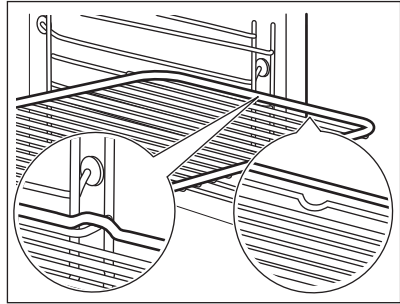

Baking tray / Deep pan:

Push the tray between the guide bars of the shelf support.

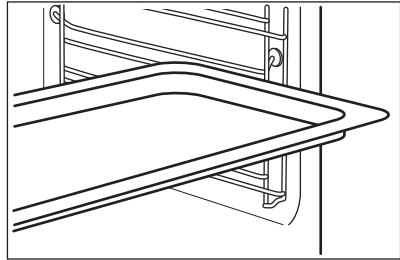

Wire shelf, Baking tray / Deep pan:

Push the tray between the guide bars of the shelf support and the wire shelf on the guide bars above.

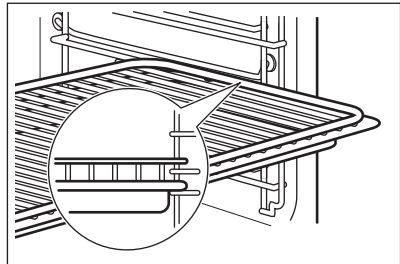

9. ADDITIONAL FUNCTIONS

9.1 Cooling fan

When the oven operates, the cooling fan turns on automatically to keep the surfaces of

the oven cool. If you turn off the oven, the cooling fan can continue to operate until the oven cools down.

10. HINTS AND TIPS



Refer to Safety chapters.

10.1 Cooking recommendations



The temperature and cooking times in the tables are guidelines only. They depend on the recipes and the quality and quantity of the ingredients used.

Your oven may bake or roast differently to the oven you had before. The tables below show recommended settings for temperature, cooking time and shelf position for specific types of the food.

If you cannot find the settings for a special recipe, look for the similar one.

10.2 Inner side of the door

On the inner side of the door you can find:

- the numbers of the shelf positions.
- information about the oven functions, recommended shelf positions and temperatures for dishes.

10.3 Baking

For the first baking, use the lower temperature.

10.4 Tips on baking





You can extend the baking time by 10 – 15 minutes if you bake cakes on more than one shelf position.

Cakes and pastries at different heights do not always brown equally. There is no need to change the temperature setting if an unequal browning occurs. The differences equalize during baking.

Trays in the oven can distort during baking. When the trays are cold again, the distortions disappear.

Baking results	Possible cause	Remedy
The bottom of the cake is not baked sufficiently.	The shelf position is incorrect.	Put the cake on a lower shelf.
The cake sinks and becomes soggy or streaky.	The oven temperature is too high.	Next time set slightly lower oven temperature.
	The oven temperature is too high and the baking time is too short.	Next time set a longer baking time and lower oven temperature.
The cake is too dry.	The oven temperature is too low.	Next time set higher oven temperature.
	The baking time is too long.	Next time set shorter baking time.
The cake bakes unevenly.	The oven temperature is too high and the baking time is too short.	Next time set a longer baking time and lower oven temperature.
	The cake batter is not evenly distributed.	Next time spread the cake batter evenly on the baking tray.
The cake is not ready in the baking time specified in a recipe.	The oven temperature is too low.	Next time set a slightly higher oven temperature.



10.5 Baking on one shelf level

 BAK- ING IN TINS		 (°C)	 (min)	
Flan base - short pastry, preheat the empty oven	True Fan Cooking	170 - 180	10 - 25	2
Flan base - sponge cake mixture	True Fan Cooking	150 - 170	20 - 25	2
Ring cake / Brioche	True Fan Cooking	150 - 160	50 - 70	1
Madeira cake / Fruit cakes	True Fan Cooking	140 - 160	70 - 90	1
Cheesecake	Conventional Cooking	170 - 190	60 - 90	1

Use the third shelf position.

Use the function: True Fan Cooking.





Use a baking tray.





 CAKES / PASTRIES / BREADS	 (°C)	 (min)
Cake with crumble topping	150 - 160	20 - 40
Fruit flans (made of yeast dough / sponge cake mixture), use a deep pan	150	35 - 55
Fruit flans made of short pastry	160 - 170	40 - 80

Preheat the empty oven.





Use the function: Conventional Cooking.

Use a baking tray.

 CAKES / PASTRIES / BREADS	 (°C)	 (min)	
Swiss roll	180 - 200	10 - 20	3
Rye bread:	first: 230	20	1
	then: 160 - 180	30 - 60	
Buttered almond cake / Sugar cakes	190 - 210	20 - 30	3
Cream puffs / Eclairs	190 - 210	20 - 35	3
Plaited bread / Bread crown	170 - 190	30 - 40	3





 CAKES / PASTRIES / BREADS	 (°C)	 (min)	
Fruit flans (made of yeast dough / sponge cake mixture), use a deep pan	170	35 - 55	3
Yeast cakes with delicate toppings (e.g. quark, cream, custard)	160 - 180	40 - 80	3
Christstollen	160 - 180	50 - 70	2

Use the third shelf position.

 BISCUITS		 (°C)	 (min)
Short pastry biscuits	True Fan Cooking	150 - 160	10 - 20
Rolls, preheat the empty oven	True Fan Cooking	160	10 - 25
Biscuits made of sponge cake mixture	True Fan Cooking	150 - 160	15 - 20
Puff pastries, preheat the empty oven	True Fan Cooking	170 - 180	20 - 30
Biscuits made of yeast dough	True Fan Cooking	150 - 160	20 - 40
Macaroons	True Fan Cooking	100 - 120	30 - 50
Pastries made of egg white / Meringues	True Fan Cooking	80 - 100	120 - 150
Rolls, preheat the empty oven	Conventional Cooking	190 - 210	10 - 25

10.6 Bakes and gratins





Use the first shelf position.





		 (°C)	 (min)
Baguettes topped with melted cheese	True Fan Cooking	160 - 170	15 - 30
Vegetables au gratin, preheat the empty oven	Turbo Grilling	160 - 170	15 - 30
Lasagne	Conventional Cooking	180 - 200	25 - 40
Fish bakes	Conventional Cooking	180 - 200	30 - 60
Stuffed vegetables	True Fan Cooking	160 - 170	30 - 60
Sweet bakes	Conventional Cooking	180 - 200	40 - 60
Pasta bake	Conventional Cooking	180 - 200	45 - 60

10.7 Multilevel Baking

Use the function: True Fan Cooking.

Use the baking trays.

 CAKES / PASTRIES	 (°C)	 (min)	 2 positions
Cream puffs / Eclairs, pre-heat the empty oven	160 - 180	25 - 45	1 / 4
Dry streusel cake	150 - 160	30 - 45	1 / 4

 BIS-CUITS / SMALL CAKES / PASTRIES / ROLLS	 (°C)	 (min)	 2 positions	 3 positions
Rolls	180	20 - 30	1 / 4	-
Short pastry biscuits	150 - 160	20 - 40	1 / 4	1 / 3 / 5
Biscuits made of sponge cake mixture	160 - 170	25 - 40	1 / 4	-
Puff pastries, pre-heat the empty oven	170 - 180	30 - 50	1 / 4	-
Biscuits made of yeast dough	160 - 170	30 - 60	1 / 4	-
Macaroons	100 - 120	40 - 80	1 / 4	-
Biscuits made of egg white / Meringues	80 - 100	130 - 170	1 / 4	-

10.8 Tips on Roasting

Use heat-resistant ovenware.

Roast lean meat covered (you can use aluminium foil).

Roast large meat joints directly in the tray or on the wire shelf placed above the tray.

Put some water in the tray to prevent dripping fat from burning.

Turn the roast after 1/2 - 2/3 of the cooking time.

Roast meat and fish in large pieces (1 kg or more).

Baste meat joints with their own juice several times during roasting.

10.9 Roasting

Use the first shelf position.

BEEF

(°C)
(min)

Pot roast	1 - 1.5 kg	Conventional Cooking	230	120 - 150
Roast beef or fillet, rare, preheat the empty oven	per cm of thickness	Turbo Grilling	190 - 200	5 - 6
Roast beef or fillet, medium, preheat the empty oven	per cm of thickness	Turbo Grilling	180 - 190	6 - 8
Roast beef or fillet, well done, preheat the empty oven	per cm of thickness	Turbo Grilling	170 - 180	8 - 10

PORK

Use the function: Turbo Grilling.

(kg)
(°C)
(min)

Shoulder / Neck / Ham joint	1 - 1.5		160 - 180	90 - 120
Chops / Spare rib	1 - 1.5		170 - 180	60 - 90
Meatloaf	0.75 - 1		160 - 170	50 - 60
Pork knuckle, precooked	0.75 - 1		150 - 170	90 - 120

VEAL

Use the function: Turbo Grilling.

(kg)
(°C)
(min)

Roast veal	1		160 - 180	90 - 120
Veal knuckle	1.5 - 2		160 - 180	120 - 150



LAMB



Use the function: **Turbo Grilling.**



(kg)



(°C)



(min)

Lamb leg / Roast lamb	1 - 1.5	150 - 170	100 - 120
Lamb saddle	1 - 1.5	160 - 180	40 - 60



GAME



Use the function: **Conventional Cooking.**



(kg)



(°C)



(min)

Saddle / Hare leg, preheat the empty oven	up to 1	230	30 - 40
Venison saddle	1.5 - 2	210 - 220	35 - 40
Haunch of venison	1.5 - 2	180 - 200	60 - 90



POULTRY



Use the function: **Turbo Grilling.**



(kg)



(°C)



(min)

Poultry, portions	0.2 - 0.25 each	200 - 220	30 - 50
Chicken, half	0.4 - 0.5 each	190 - 210	35 - 50
Chicken, poulard	1 - 1.5	190 - 210	50 - 70
Duck	1.5 - 2	180 - 200	80 - 100
Goose	3.5 - 5	160 - 180	120 - 180
Turkey	2.5 - 3.5	160 - 180	120 - 150
Turkey	4 - 6	140 - 160	150 - 240



FISH (STEAMED)



Use the function: **Conventional Cooking.**



(kg)



(°C)



(min)

Whole fish

1 - 1.5

210 - 220

40 - 60

10.10 Crispy baking with: Pizza Function



PIZZA



Use the first shelf position.



(°C)



(min)

Tarts

180 - 200

40 - 55

Spinach flan

160 - 180

45 - 60

Quiche lorraine /
Swiss flan

170 - 190

45 - 55

Cheesecake

140 - 160

60 - 90

Vegetable pie

160 - 180

50 - 60



PIZZA



Preheat the empty oven before cooking.



Use the second shelf position.



(°C)



(min)

Pizza, thin crust,
use a deep pan

200 - 230

15 - 20



PIZZA



Preheat the empty oven before cooking.



Use the second shelf position.



(°C)



(min)

Pizza, thick
crust

180 - 200

20 - 30

Unleavened
bread

230 - 250

10 - 20

Puff pastry flan

160 - 180

45 - 55

Flammkuchen

230 - 250

12 - 20

Pierogi

180 - 200

15 - 25

10.11 Grill

Preheat the empty oven before cooking.

Grill only thin pieces of meat or fish.

Put a pan on the first shelf position to collect fat.



GRILL



Use the function: Grill



(°C)



(min)
1st side



(min)
2nd side



	(°C)	(min) 1st side	(min) 2nd side	
Roast beef	210 - 230	30 - 40	30 - 40	2
Beef fillet	230	20 - 30	20 - 30	3
Pork loin	210 - 230	30 - 40	30 - 40	2
Veal loin	210 - 230	30 - 40	30 - 40	2
Lamb saddle	210 - 230	25 - 35	20 - 25	3
Whole fish, 0.5 kg - 1 kg	210 - 230	15 - 30	15 - 30	3 / 4

10.12 Frozen Foods



DEFROSTING



Use the function: True Fan Cooking.



(°C)



(min)



	(°C)	(min)	
Pizza, frozen	200 - 220	15 - 25	2
Pizza American, frozen	190 - 210	20 - 25	2
Pizza, chilled	210 - 230	13 - 25	2
Pizza snacks, frozen	180 - 200	15 - 30	2
French fries, thin	200 - 220	20 - 30	3
French fries, thick	200 - 220	25 - 35	3
Wedges / Croquettes	220 - 230	20 - 35	3
Hash browns	210 - 230	20 - 30	3
Lasagne / Cannelloni, fresh	170 - 190	35 - 45	2
Lasagne / Cannelloni, frozen	160 - 180	40 - 60	2
Baked cheese	170 - 190	20 - 30	3
Chicken wings	190 - 210	20 - 30	2





10.13 Defrost

Remove the food packaging and put the food on a plate.

Do not cover the food, as this can extend the defrost time.

Use the first shelf position.

For large portions of food place an upturned empty plate on the bottom of the oven cavity. Put the food in a deep dish and set it on top of the plate inside the oven. Remove the shelf supports if necessary.

	 (kg)	 (min) Defrosting time	 (min) Further defrosting time	
Chicken	1	100 - 140	20 - 30	Turn halfway through.
Meat	1	100 - 140	20 - 30	Turn halfway through.
Trout	0.15	25 - 35	10 - 15	-
Strawberries	0.3	30 - 40	10 - 20	-
Butter	0.25	30 - 40	10 - 15	-
Cream	2 x 0.2	80 - 100	10 - 15	Whip the cream when still slightly frozen in places.
Gateau	1.4	60	60	-

10.14 Preserving

Use the function Bottom Heat.

Use only preserve jars of the same dimensions available on the market.

Do not use jars with twist-off and bayonet type lids or metal tins.

Use the first shelf position.

Put no more than six one-litre preserve jars on the baking tray.



Fill the jars equally and close with a clamp.



The jars cannot touch each other.



Put approximately 1/2 litre of water into the baking tray to give sufficient moisture in the oven.

When the liquid in the jars starts to simmer (after approximately 35 - 60 minutes with one-litre jars), stop the oven or decrease the temperature to 100 °C (see the table).

Set the temperature to 160 - 170 °C.

 SOFT FRUIT	 (min) Cooking time until simmering
Strawberries / Blueberries / Raspberries / Ripe gooseberries	35 - 45

 STONE FRUIT	 (min) Cooking time until simmering	 (min) Continue to cook at 100 °C
Peaches / Quinces / Plums	35 - 45	10 - 15

 VEG-ETABLES	 (min) Cooking time until simmering	 (min) Continue to cook at 100 °C
Carrots	50 - 60	5 - 10
Cucumbers	50 - 60	-
Mixed pickles	50 - 60	5 - 10
Kohlrabi / Peas / Asparagus	50 - 60	15 - 20

10.15 Dehydrating - True Fan Cooking

Cover trays with grease proof paper or baking parchment.

For a better result, stop the oven halfway through the drying time, open the door and let it cool down for one night to complete the drying.

For 1 tray use the third shelf position.

For 2 trays use the first and fourth shelf position.

10.16 Moist Fan Baking - recommended accessories

Use the dark and non-reflective tins and containers. They have better heat absorption than the light colour and reflective dishes.



Pizza pan

Dark, non-reflective
28 cm diameter

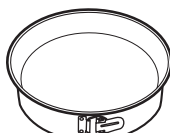

Baking dish

Dark, non-reflective
26 cm diameter



Ramekins

Ceramic
8 cm diameter, 5 cm height





Flan base tin



Dark, non-reflective
28 cm diameter





10.17 Moist Fan Baking

For the best results follow suggestions listed in the table below.

 VEGETABLES	 (°C)	 (h)
Beans	60 - 70	6 - 8
Peppers	60 - 70	5 - 6
Vegetables for soup	60 - 70	5 - 6
Mushrooms	50 - 60	6 - 8
Herbs	40 - 50	2 - 3







Set the temperature to 60 - 70 °C.







 FRUIT	 (h)
Plums	8 - 10
Apricots	8 - 10
Apple slices	6 - 8
Pears	6 - 9

	 (°C)	 (min)	
Bread sticks, 0.5 kg in total	190 - 200	50 - 60	3
Baked scallops in shells	180 - 200	30 - 40	4
Whole fish in salt, 0.3 - 0.5 kg	190 - 200	45 - 50	4
Whole fish in parchment, 0.3 - 0.5 kg	190 - 200	50 - 60	3
Amaretti (20; 0.5 kg in total)	170 - 180	40 - 50	3
Apple crumble	190 - 200	50 - 60	4
Chocolate muffins (20; 0.5 kg in total)	160 - 170	35 - 45	3

10.18 Information for test institutes

Tests according to: EN 60350, IEC 60350.

 BAKING ON ONE LEVEL. Baking in tins				
		 (°C)	 (min)	
Fatless sponge cake	True Fan Cooking	140 - 150	35 - 50	2
Fatless sponge cake	Conventional Cooking	160	35 - 50	2
Apple pie, 2 tins Ø20 cm	True Fan Cooking	160	60 - 90	2
Apple pie, 2 tins Ø20 cm	Conventional Cooking	180	70 - 90	1

 BAKING ON ONE LEVEL. Biscuits				
 Use the third shelf position.				
		 (°C)	 (min)	
Short bread / Pastry strips	True Fan Cooking	140	25 - 40	
Short bread / Pastry strips, pre-heat the empty oven	Conventional Cooking	160	20 - 30	
Small cakes, 20 per tray, preheat the empty oven	True Fan Cooking	150	20 - 35	
Small cakes, 20 per tray, preheat the empty oven	Conventional Cooking	170	20 - 30	



MULTILEVEL BAKING. Biscuits



(°C)



(min)



Short bread / Pastry strips	True Fan Cooking	140	25 - 45	1 / 4
Small cakes, 20 per tray, pre-heat the empty oven	True Fan Cooking	150	23 - 40	1 / 4
Fatless sponge cake	True Fan Cooking	160	35 - 50	1 / 4



GRILL



Preheat the empty oven for 5 minutes.



Grill with the maximum temperature setting.



(min)



Toast	Grill	1 - 3	5	
Beef steak, turn halfway through	Grill	24 - 30	4	

11. CARE AND CLEANING



WARNING!

Refer to Safety chapters.

11.1 Notes on cleaning



Clean the front of the oven with a soft cloth with warm water and a mild detergent.

Use a cleaning solution to clean metal surfaces.

Clean stains with a mild detergent.

Cleaning Agents



Clean the cavity after each use. Fat accumulation or other residue may cause fire.

Do not store the food in the oven for longer than 20 minutes. Dry the cavity with a soft cloth after each use.

Everyday Use



Clean all accessories after each use and let them dry. Use a soft cloth with warm water and a mild detergent. Do not clean the accessories in a dishwasher.

Do not clean the non-stick accessories using abrasive cleaner or sharp-edged objects.

Accessories

11.2 How to remove: Shelf supports

Remove the shelf supports to clean the oven.

Step 1 Turn off the oven and wait until it is cold.

Step 2 Pull the front of the shelf support away from the side wall.

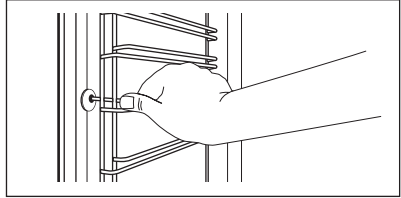

Step 3 Pull the rear end of the shelf support away from the side wall and remove it.

Step 4 Install the shelf supports in the opposite sequence.

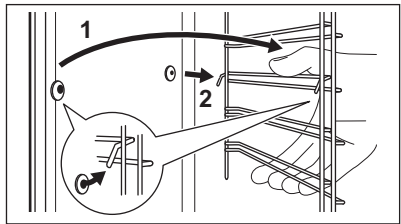

11.3 How to remove: Grill



WARNING!

There is a risk of burns.

Step 1 Turn off the oven and wait until it is cold to clean it.
Remove the shelf supports.

Step 2 Grab the grill corners. Pull it forwards against the spring pressure and out of two holders. The grill folds down.

Step 3 Clean the oven ceiling with warm water, a soft cloth and a mild detergent. Let it dry.

Step 4 Install the grill in the opposite sequence.

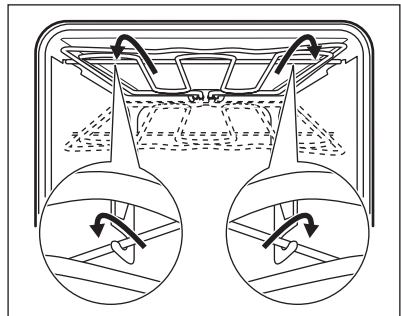

Step 5 Install the shelf supports.

11.4 How to remove and install:

The number of glass panels is different for different models.



CAUTION!

Carefully handle the glass, especially around the edges of the front panel. The glass can break.

11.5 How to replace: Lamp



WARNING!

Risk of electric shock.
The lamp can be hot.

Before you replace the lamp:

Step 1	Step 2	Step 3
Turn off the oven. Wait until the oven is cold.	Disconnect the oven from the mains.	Put a cloth on the bottom of the cavity.

Top lamp

Step 1 Turn the glass cover to remove it.

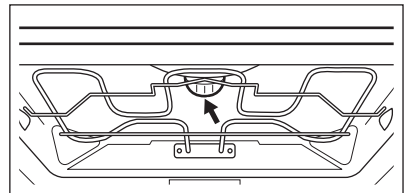

Step 2 Clean the glass cover.

Step 3 Replace the lamp with a suitable 300 °C heat-resistant lamp.

Step 4 Install the glass cover.

12. TROUBLESHOOTING



WARNING!

Refer to Safety chapters.

12.1 What to do if...

In any cases not included in this table please contact with an Authorised Service Centre.

Problem	Check if...
The oven does not heat up.	The fuse is blown.
The display shows "12.00".	There was a power cut. Set the time of day.

Problem	Check if...
The lamp does not work.	The lamp is burnt out.

12.2 Service data

If you cannot find a solution to the problem yourself, contact your dealer or an Authorised Service Centre.

The necessary data for the service centre is on the rating plate. The rating plate is on the front frame of the oven cavity. Do not remove the rating plate from the oven cavity.

We recommend that you write the data here:

Model (MOD.)
Product number (PNC)
Serial number (S.N.)

13. ENERGY EFFICIENCY

13.1 Product Information and Product Information Sheet*

Supplier's name	AEG
Model identification	BEK435220M 944188023
Energy Efficiency Index	81.2
Energy efficiency class	A+
Energy consumption with a standard load, conventional mode	0.99 kWh/cycle
Energy consumption with a standard load, fan-forced mode	0.69 kWh/cycle
Number of cavities	1
Heat source	Electricity
Volume	71 l
Type of oven	Built-In Oven
Mass	34.0 kg

* For European Union according to EU Regulations 65/2014 and 66/2014.
For Republic of Belarus according to STB 2478-2017, Appendix G; STB 2477-2017, Annexes A and B.
For Ukraine according to 568/32020.

Energy efficiency class is not applicable for Russia.

EN 60350-1 - Household electric cooking appliances - Part 1: Ranges, ovens, steam ovens and grills - Methods for measuring performance.

13.2 Energy saving



The oven has features which help you save energy during everyday cooking.

Make sure that the oven door is closed when the oven operates. Do not open the oven door too often during cooking. Keep the door gasket clean and make sure it is well fixed in its position.

Use metal cookware to improve energy saving.

When possible, do not preheat the oven before cooking.

Keep breaks between baking as short as possible when you prepare a few dishes at one time.

Cooking with fan

When possible, use the cooking functions with fan to save energy.

Residual heat

When the cooking duration is longer than 30 min, reduce the oven temperature to minimum 3 - 10 min before the end of cooking. The residual heat inside the oven will continue to cook.

Use the residual heat to warm up other dishes.

Keep food warm

Choose the lowest possible temperature setting to use residual heat and keep a meal warm.

Moist Fan Baking

Function designed to save energy during cooking.

14. ENVIRONMENTAL CONCERNS

Recycle materials with the symbol . Put the packaging in relevant containers to recycle it. Help protect the environment and human health by recycling waste of electrical and electronic appliances. Do not dispose of

appliances marked with the symbol  with the household waste. Return the product to your local recycling facility or contact your municipal office.

POUR DES RÉSULTATS PARFAITS

Merci d'avoir choisi ce produit AEG. Nous l'avons conçu pour vous offrir des performances irréprochables pendant longtemps, avec des technologies innovantes qui simplifient la vie : autant de caractéristiques que vous ne trouverez peut-être pas sur des appareils ordinaires. Veuillez prendre quelques instants pour lire cette notice afin d'utiliser au mieux votre appareil.

Visitez notre site Web pour :



Obtenir des conseils d'utilisation, des brochures, un dépanneur, des informations sur le service et les réparations :

www.aeg.com/support



Enregistrer votre produit pour un meilleur service :

www.registeraeg.com



Acheter des accessoires, des consommables et des pièces de rechange d'origine pour votre appareil :

www.aeg.com/shop

SERVICE ET ASSISTANCE À LA CLIENTÈLE

Utilisez toujours des pièces de rechange d'origine.

Avant de contacter notre centre de service agréé, assurez-vous de disposer des informations suivantes : Modèle, PNC, Numéro de série.

Les informations se trouvent sur la plaque signalétique.

 Avertissement/Mise en garde-Information de sécurité

 Informations générales et conseils

 Informations environnementales

Sous réserve de modifications.

TABLE DES MATIÈRES

1. INFORMATION SUR LA SÉCURITÉ.....	28
2. CONSIGNES DE SÉCURITÉ.....	30
3. DESCRIPTION DE L'APPAREIL.....	33
4. BANDEAU DE COMMANDE.....	34
5. AVANT LA PREMIÈRE UTILISATION.....	34
6. UTILISATION QUOTIDIENNE.....	35
7. FONCTIONS DE L'HORLOGE.....	36
8. UTILISATION DES ACCESSOIRES.....	37
9. FONCTIONS SUPPLÉMENTAIRES.....	38
10. CONSEILS ET ASTUCES.....	38
11. ENTRETIEN ET NETTOYAGE.....	51
12. DÉPANNAGE.....	54
13. RENDEMENT ÉNERGÉTIQUE.....	54

1. INFORMATION SUR LA SÉCURITÉ

Avant d'installer et d'utiliser cet appareil, lisez soigneusement les instructions fournies. Le fabricant ne pourra être tenu pour

responsable des blessures et dégâts résultant d'une mauvaise installation ou utilisation. Conservez toujours les instructions dans un lieu sûr et accessible pour vous y référer ultérieurement.

1.1 Sécurité des enfants et des personnes vulnérables

- Cet appareil peut être utilisé par des enfants âgés d'au moins 8 ans et par des personnes ayant des capacités physiques, sensorielles ou mentales réduites ou dénuées d'expérience ou de connaissance, s'ils sont correctement surveillés ou si des instructions relatives à l'utilisation de l'appareil en toute sécurité leur ont été données et s'ils comprennent les risques encourus. Les enfants de moins de 8 ans et les personnes ayant un handicap très important et complexe doivent être tenus à l'écart de l'appareil, à moins d'être surveillés en permanence.
- Ne laissez pas les enfants jouer avec l'appareil.
- Ne laissez pas les emballages à la portée des enfants et jetez-les convenablement.
- **AVERTISSEMENT** : Tenez les enfants et les animaux éloignés de l'appareil lorsqu'il est en cours de fonctionnement ou lorsqu'il refroidit. Les parties accessibles deviennent chaudes en cours d'utilisation.
- Si l'appareil est équipé d'un dispositif de sécurité enfants, nous vous recommandons de l'activer.
- Le nettoyage et l'entretien ne doivent pas être effectués par des enfants sans surveillance.

1.2 Consignes générales de sécurité

- L'appareil doit être installé et le câble remplacé uniquement par un professionnel qualifié.
- **AVERTISSEMENT** : L'appareil et ses parties accessibles deviennent chauds pendant son fonctionnement. Veillez à ne pas toucher les éléments chauffants.
- Utilisez toujours des gants de cuisine pour retirer ou enfourner des accessoires ou des plats allant au four.

- Avant d'effectuer une opération de maintenance, débranchez l'appareil de la prise secteur.
- **AVERTISSEMENT** : Assurez-vous que l'appareil est éteint et débranché avant de remplacer l'éclairage afin d'éviter tout risque de choc électrique.
- N'utilisez pas l'appareil avant de l'avoir installé dans la structure encastrée.
- N'utilisez pas de nettoyeur vapeur pour nettoyer l'appareil.
- N'utilisez pas de produits abrasifs ni de racloirs pointus en métal pour nettoyer la porte en verre car ils peuvent rayer sa surface, ce qui peut briser le verre.
- Si le câble d'alimentation est endommagé, il doit être remplacé par le fabricant, un service de maintenance agréé ou un technicien qualifié afin d'éviter tout danger lié à l'électricité.
- Pour retirer les supports de grille, tirez d'abord sur l'avant de ceux-ci, puis sur l'arrière, pour les écarter des parois extérieures. Réinstallez les supports de grille en répétant cette procédure dans l'ordre inverse.

2. CONSIGNES DE SÉCURITÉ

2.1 Installation



AVERTISSEMENT!

L'appareil doit être installé uniquement par un professionnel qualifié.

- Retirez l'intégralité de l'emballage.
- N'installez pas et ne branchez pas un appareil endommagé.
- Suivez scrupuleusement les instructions d'installation fournies avec l'appareil.
- Soyez toujours vigilants lorsque vous déplacez l'appareil car il est lourd. Utilisez toujours des gants de sécurité et des chaussures fermées.
- Ne tirez jamais l'appareil par la poignée.
- Installez l'appareil dans un lieu sûr et adapté répondant aux exigences d'installation.
- Respectez l'espacement minimal requis par rapport aux autres appareils et éléments.

- Avant de monter l'appareil, vérifiez si la porte du four s'ouvre sans retenue.
- Cet appareil est équipé d'un système de refroidissement électrique. Il doit être utilisé lorsque l'appareil est raccordé à une prise secteur.
- La stabilité de l'élément encastré doit être conforme à la norme DIN 68930.

Hauteur minimale du meuble (Hauteur minimale du meuble sous le plan de travail)	578 (600) mm
---------------------------------------------------------------------------------	--------------

Largeur du meuble	560 mm
-------------------	--------

Profondeur du meuble	550 (550) mm
----------------------	--------------

Hauteur de l'avant de l'appareil	594 mm
----------------------------------	--------

Hauteur de l'arrière de l'appareil	576 mm
------------------------------------	--------

Largeur de l'avant de l'appareil	595 mm
----------------------------------	--------

Largeur de l'arrière de l'appareil	559 mm
Profondeur de l'appareil	567 mm
Profondeur d'encastrement de l'appareil	546 mm
Profondeur avec porte ouverte	1027 mm
Dimensions minimales de l'ouverture de ventilation. Ouverture placée sur la partie inférieure de la face arrière	560 x 20 mm
Longueur du câble d'alimentation secteur. Le câble est placé dans le coin droit de la face arrière	1500 mm
Vis de montage	4 x 25 mm

2.2 Raccordement électrique



AVERTISSEMENT!

Risque d'incendie ou d'électrocution.

- Tous les raccordements électriques doivent être effectués par un électricien qualifié.
- L'appareil doit être relié à la terre.
- Assurez-vous que les paramètres figurant sur la plaque signalétique correspondent aux données électriques nominale de l'alimentation secteur.
- Utilisez toujours une prise de courant de sécurité correctement installée.
- N'utilisez pas d'adaptateurs multiprise et de rallonges.
- Veillez à ne pas endommager la fiche secteur ni le câble d'alimentation. Le remplacement du câble d'alimentation de l'appareil doit être effectué par notre service après-vente agréé.
- Ne laissez pas les câbles d'alimentation entrer en contact ou s'approcher de la porte de l'appareil ou de la niche d'encastrement sous l'appareil, particulièrement lorsqu'il est en marche ou que la porte est chaude.
- La protection contre les chocs des parties sous tension et isolées doit être fixée de telle manière qu'elle ne puisse pas être enlevée sans outils.
- Ne branchez la fiche secteur dans la prise secteur qu'à la fin de l'installation.

Assurez-vous que la prise secteur est accessible après l'installation.

- Si la prise secteur est détachée, ne branchez pas la fiche secteur.
- Ne tirez pas sur le câble secteur pour débrancher l'appareil. Tirez toujours sur la fiche de la prise secteur.
- N'utilisez que des systèmes d'isolation appropriés : des coupe-circuits, des fusibles (les fusibles à visser doivent être retirés du support), un disjoncteur différentiel et des contacteurs.
- L'installation électrique doit comporter un dispositif d'isolation qui vous permet de déconnecter l'appareil du secteur à tous les pôles. Le dispositif d'isolement doit avoir une largeur d'ouverture de contact de 3 mm minimum.
- Cet appareil est fourni avec une fiche d'alimentation et un câble d'alimentation.

2.3 Utilisation



AVERTISSEMENT!

Risque de blessures, de brûlures, d'électrocution ou d'explosion.

- Cet appareil est exclusivement destiné à une utilisation domestique.
- Ne modifiez pas les caractéristiques de cet appareil.
- Assurez-vous que les orifices de ventilation ne sont pas bouchés.
- Ne laissez jamais l'appareil sans surveillance pendant son fonctionnement.
- Éteignez l'appareil après chaque utilisation.
- Soyez prudent lors de l'ouverture de la porte de l'appareil lorsque celui-ci est en fonctionnement. De l'air brûlant peut s'en échapper.
- N'utilisez jamais cet appareil avec les mains mouillées ou lorsqu'il est en contact avec de l'eau.
- N'exercez jamais de pression sur la porte ouverte.
- N'utilisez jamais l'appareil comme plan de travail ou comme plan de stockage.
- Ouvrez prudemment la porte de l'appareil. Si vous utilisez des ingrédients contenant de l'alcool, un mélange d'alcool et d'air facilement inflammable peut éventuellement se former.

- Ne laissez pas des étincelles ou des flammes nues entrer en contact avec l'appareil lorsque vous ouvrez la porte.
- Ne placez pas de produits inflammables ou d'éléments imbibés de produits inflammables à l'intérieur ou à proximité de l'appareil, ni sur celui-ci.



AVERTISSEMENT!

Risque d'endommagement de l'appareil.

- Pour éviter tout endommagement ou décoloration de l'émail :
 - ne posez pas de plats allant au four ni aucun autre objet directement sur le fond de l'appareil.
 - ne placez jamais de feuilles d'aluminium directement sur le fond de la cavité de l'appareil.
 - ne versez jamais d'eau directement dans l'appareil lorsqu'il est chaud.
 - une fois la cuisson terminée, ne laissez jamais d'aliments ou de plats humides à l'intérieur de l'appareil.
 - faites attention lorsque vous retirez ou remettez en place les accessoires.
- La décoloration de l'émail ou de l'acier inoxydable est sans effet sur les performances de l'appareil.
- Utilisez un plat à rôtir pour obtenir des gâteaux moelleux. Les jus de fruits causent des taches qui peuvent être permanentes.
- Cet appareil est exclusivement destiné à un usage culinaire. Ne l'utilisez pas pour des usages autres que celui pour lequel il a été conçu, à des fins de chauffage par exemple.
- La porte du four doit toujours être fermée pendant la cuisson.
- Si l'appareil est installé derrière la paroi d'un meuble (par ex. une porte), veuillez à ce que la porte ne soit jamais fermée lorsque l'appareil fonctionne. La chaleur et l'humidité peuvent s'accumuler derrière la porte fermée du meuble et provoquer d'importants dégâts sur l'appareil, le meuble ou le sol. Ne fermez pas la paroi du meuble tant que l'appareil n'a pas complètement refroidi.

2.4 Entretien et Nettoyage



AVERTISSEMENT!

Risque de blessure, d'incendie ou de dommages matériels sur l'appareil.

- Avant toute opération d'entretien, éteignez l'appareil et débranchez la fiche de la prise secteur.
- Vérifiez que l'appareil est froid. Les panneaux de verre risquent de se briser.
- Remplacez immédiatement les vitres de la porte si elles sont endommagées. Contactez le service après-vente agréé.
- Nettoyez régulièrement l'appareil afin de maintenir le revêtement en bon état.
- Nettoyez l'appareil avec un chiffon doux humide. Utilisez uniquement des produits de lavage neutres. N'utilisez pas de produits abrasifs, de tampons à récurer, de solvants ni d'objets métalliques.
- Si vous utilisez un spray pour four, suivez les consignes de sécurité figurant sur son emballage.

2.5 Éclairage intérieur



AVERTISSEMENT!

Risque d'électrocution !

- Concernant la/les lampe(s) à l'intérieur de ce produit et les lampes de rechange vendues séparément : Ces lampes sont conçues pour résister à des conditions physiques extrêmes dans les appareils électroménagers, telles que la température, les vibrations, l'humidité, ou sont conçues pour signaler des informations sur le statut opérationnel de l'appareil. Elles ne sont pas destinées à être utilisées dans d'autres applications et ne conviennent pas à l'éclairage des pièces d'un logement.
- Utilisez uniquement des ampoules ayant les mêmes spécifications.

2.6 Maintenance

- Pour réparer l'appareil, contactez un service après-vente agréé.
- Utilisez exclusivement des pièces d'origine.

2.7 Mise au rebut



AVERTISSEMENT!

Risque de blessure ou d'asphyxie.

- Débranchez l'appareil de l'alimentation électrique.

- Coupez le câble d'alimentation au ras de l'appareil et mettez-le au rebut.
- Retirez le dispositif de verrouillage du hublot pour empêcher les enfants et les animaux de s'enfermer dans l'appareil.

3. DESCRIPTION DE L'APPAREIL

3.1 Présentation générale

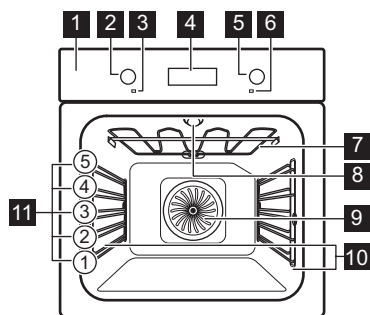

- 1 Bandeau de commande
- 2 Manette de sélection des modes de cuisson
- 3 Voyant / symbole de mise sous tension
- 4 Affichage
- 5 Thermostat
- 6 Indicateur / symbole de température
- 7 Élément chauffant
- 8 Éclairage
- 9 Ventilateur
- 10 Support de grille, amovible
- 11 Position des grilles

3.2 Accessoires

Grille métallique

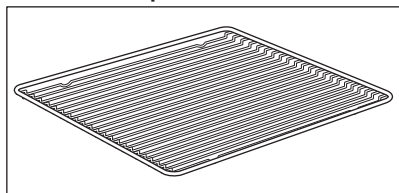

Pour les plats à rôtir, à gratin et les moules à gâteau/pâtisserie.

Plateau de cuisson

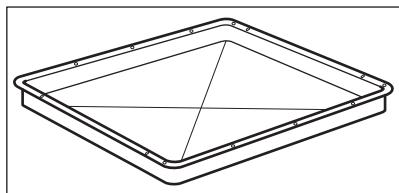

Pour gâteaux et biscuits.

Plat à rôtir

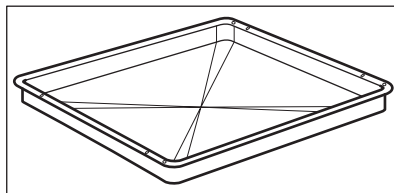

Pour cuire et griller ou à utiliser comme plat pour recueillir la graisse.

4. BANDEAU DE COMMANDE

4.1 Manettes rétractables

Pour utiliser l'appareil, appuyez sur la manette. La manette sort alors de son logement.

4.2 Touches sensibles

—	Pour régler l'heure.
	Pour régler une fonction de l'horloge.
+	Pour régler l'heure.

4.3 Affichage

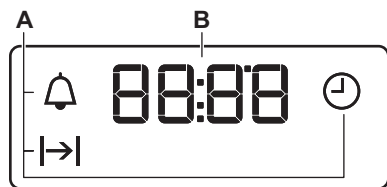

- A. Fonctions de l'horloge
- B. Minuteur

5. AVANT LA PREMIÈRE UTILISATION



AVERTISSEMENT!

Reportez-vous aux chapitres concernant la sécurité.

5.1 Avant la première utilisation

Le four peut produire une odeur et de la fumée lors du préchauffage. Assurez-vous que la pièce est ventilée.



Étape 1

Réglez l'horloge









Étape 2

Nettoyez le four



Étape 3

Préchauffez le four à vide

- | | | |
|-----------------------------------------------------------------------------------------------------------------------------------------------------------------------------------------------------------------------------------------------------------------------------------------------------------------------------------------------------------------------------------------------------------------------------------------------------------------------------------------------------------------------------------------------------------------------------------------------------------------------|-------------------------------------------------------------------------------------------------------------------------------------------------------------------------------------------------------------------------------------------|--------------------------------------------------------------------------------------------------------------------------------------------------------------------------------------------------------------------------------------------------------------------------------------------------------------------------------------------------------------------------------|
| <ol style="list-style-type: none"> 1. Appuyez sur : . 2.  - appuyez pour régler l'heure. Appuyez sur : . 3.  - appuyez pour régler les minutes. Appuyez sur : . | <ol style="list-style-type: none"> 1. Retirez les supports de grille amovibles et tous les accessoires du four. 2. Nettoyez le four et les accessoires avec un chiffon doux, de l'eau tiède et un détergent doux. | <ol style="list-style-type: none"> 1. Réglez la température maximale pour la fonction : .
Durée : 1 h 2. Réglez la température maximale pour la fonction : .
Durée : 15 min. |
|-----------------------------------------------------------------------------------------------------------------------------------------------------------------------------------------------------------------------------------------------------------------------------------------------------------------------------------------------------------------------------------------------------------------------------------------------------------------------------------------------------------------------------------------------------------------------------------------------------------------------|-------------------------------------------------------------------------------------------------------------------------------------------------------------------------------------------------------------------------------------------|--------------------------------------------------------------------------------------------------------------------------------------------------------------------------------------------------------------------------------------------------------------------------------------------------------------------------------------------------------------------------------|

Éteignez le four et attendez qu'il soit froid. Placez les accessoires et les supports de grille amovibles dans le four.

6. UTILISATION QUOTIDIENNE



AVERTISSEMENT!

Reportez-vous aux chapitres concernant la sécurité.

6.1 Comment régler : Mode de cuisson

Étape 1 Tournez la manette des modes de cuisson pour sélectionner un mode de cuisson.

Étape 2 Tournez la manette pour sélectionner la température.

Étape 3 Une fois la cuisson terminée, tournez les manettes sur la position Arrêt pour éteindre le four.

6.2 Modes de cuisson

Mode de cuisson	Application
-----------------	-------------



Position Arrêt

Le four est éteint.



Éclairage four

Pour allumer l'éclairage.



Chaleur tournante

Pour faire cuire sur 3 niveaux en même temps et pour déshydrater des aliments. Diminuez les températures du four de 20 à 40 °C par rapport à la Chauffage Haut/ Bas.



Fonction Pizza

Pour cuire des pizzas. Pour dorer de façon intensive et obtenir un fond croustillant.

Mode de cuisson	Application
-----------------	-------------



Chauffage Haut/ Bas

Pour cuire et rôtir des aliments sur un seul niveau.



Cuisson de sole

Pour cuire des gâteaux à fond croustillant et pour stériliser des aliments.



Décongélation

Pour décongeler des aliments (fruits et légumes). Le temps de décongélation dépend de la quantité et de l'épaisseur des aliments surgelés.



Chaleur tournante humide

Cette fonction est conçue pour économiser de l'énergie en cours de cuisson. Lorsque vous utilisez cette fonction, la température à l'intérieur de la cavité peut différer de la température sélectionnée. La chaleur résiduelle est utilisée. La puissance peut être réduite. Pour plus d'informations, consultez le chapitre « Utilisation quotidienne », Remarques sur : Chaleur tournante humide.



Gril

Pour faire griller des aliments peu épais et du pain.



Turbo gril

Pour rôtir de grosses pièces de viande ou de volaille avec os sur un seul niveau. Également pour gratiner et faire dorer.



Durant certaines fonctions, l'éclairage s'éteint automatiquement lorsque le four atteint une température inférieure à 60 °C.

6.3 Remarques sur : Chaleur tournante humide



Cette fonction était utilisée pour se conformer à la classe d'efficacité énergétique et aux exigences d'éco-conception selon les normes EU 65/2014 et EU 66/2014. Tests conformément à la norme EN 60350-1.

Pendant la cuisson, la porte du four doit rester fermée pour éviter d'interrompre la fonction et pour un fonctionnement avec la meilleure efficacité énergétique possible.

Pour obtenir des instructions de cuisson, reportez-vous au chapitre « Conseils », paragraphe Chaleur tournante humide. Pour obtenir des recommandations générales sur les économies d'énergie, consultez le chapitre « Efficacité énergétique, « Four - Économie d'énergie ».

7. FONCTIONS DE L'HORLOGE



7.1 Fonctions de l'horloge



Fonction de l'horloge	Utilisation
 Heure	Pour régler, changer ou vérifier l'heure.
 Durée	Pour régler la durée de fonctionnement du four.
 Minuteur	Pour régler la minuterie. Cette fonction est sans effet sur le fonctionnement du four. Vous pouvez régler cette fonction à tout moment, même quand le four est éteint.



7.2 Comment régler : Fonctions de l'horloge

Comment modifier : Heure

 - clignote lorsque vous branchez le four à l'alimentation électrique, lorsqu'il y a eu une coupure de courant ou que le minuteur n'est pas réglé.

Étape 1  - appuyez à plusieurs reprises.  - commence à clignoter.

Étape 2  ,  - appuyez pour régler l'heure.
Après environ 5 s, le symbole cesse de clignoter et l'heure s'affiche.





 - appuyez à plusieurs reprises pour modifier l'heure.  - commence à clignoter.

Comment régler : Durée





Étape 1 Sélectionnez une fonction du four et la température.

Étape 2  - appuyez à plusieurs reprises.  - commence à clignoter.



Comment régler : Durée

- Étape 3**  ,  - appuyez pour régler la durée.
L'affichage indique : .
 - clignote lorsque la durée définie est écoulée. Le signal sonore retentit et le four s'éteint.
- Étape 4** Appuyez sur n'importe quelle touche pour arrêter le signal sonore.
- Étape 5** Tournez la manette sur la position Arrêt.

Comment régler : Minuteur

- Étape 1**  - appuyez à plusieurs reprises.  - commence à clignoter.
- Étape 2**  ,  - appuyez pour régler l'heure.
La fonction démarre automatiquement au bout de 5 s.
Lorsque la durée définie est écoulée, un signal sonore retentit.
- Étape 3** Appuyez sur n'importe quelle touche pour arrêter le signal sonore.
- Étape 4** Tournez la manette sur la position Arrêt.

Comment annuler : Fonctions de l'horloge

- Étape 1**  - appuyez plusieurs fois jusqu'à ce que le symbole de la fonction horloge commence à clignoter.
- Étape 2** Maintenez la touche : .
La fonction horloge est désactivée au bout de quelques secondes.

8. UTILISATION DES ACCESSOIRES



AVERTISSEMENT!

Reportez-vous aux chapitres concernant la sécurité.

8.1 Insertion des accessoires

Une petite indentation sur le dessus apporte plus de sécurité. Les indentations sont

également des dispositifs anti-bascule. Le rebord élevé de la grille empêche les ustensiles de cuisine de glisser.

Grille métallique:

Poussez la grille entre les barres de guidage des supports de grille.

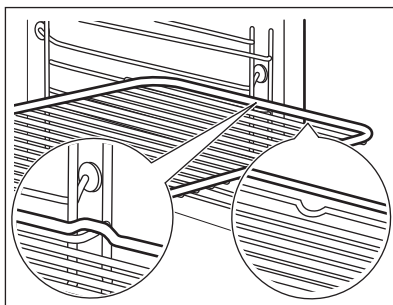
**Plateau de cuisson /Lèche-frite:**

Poussez le plateau entre les rails du support de grille.

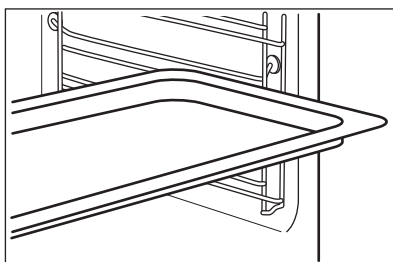
**Grille métallique, Plateau de cuisson /Lèche-frite:**

Poussez le plateau entre les rails du support de grille et glissez la grille métallique entre les rails se trouvant juste au-dessus.

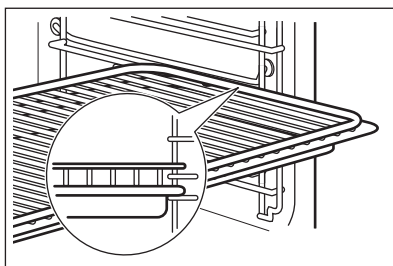

9. FONCTIONS SUPPLÉMENTAIRES

9.1 Ventilateur de refroidissement

Lorsque le four fonctionne, le ventilateur de refroidissement se met automatiquement en marche pour refroidir les surfaces du four. Si

vous éteignez le four, le ventilateur de refroidissement continue à fonctionner jusqu'à ce que le four refroidisse.

10. CONSEILS ET ASTUCES



Reportez-vous aux chapitres concernant la sécurité.

10.1 Recommandations de cuisson



Les températures et temps de cuisson se trouvant dans les tableaux ne sont indiqués qu'à titre indicatif. Ils varient en fonction des recettes ainsi que de la qualité et de la quantité des ingrédients utilisés.

Votre four peut cuire les aliments d'une manière complètement différente de celle de votre ancien four. Les tableaux ci-dessous contiennent les réglages de température, les temps de cuisson et les positions de grilles recommandés pour des types de plats en particulier.

Si vous ne trouvez pas les réglages appropriés pour une recette spécifique, cherchez-en une qui s'en rapproche.

10.2 Intérieur de la porte

Vous trouverez à l'intérieur de la porte du four :

- les numéros des niveaux d'enfournement.
- des informations sur les fonctions du four, les niveaux d'enfournement et les températures recommandés pour certains plats.

10.3 Cuisson

Pour la première cuisson, utilisez la température inférieure.

Le temps de cuisson peut être prolongé de 10 à 15 minutes, si vous cuisez des gâteaux sur plusieurs niveaux.





Les gâteaux et petites pâtisseries placés à différentes hauteurs ne dorent pas toujours de manière homogène. S'ils ne dorent uniformément, il n'est pas nécessaire de modifier la température. Les différences s'atténuent en cours de cuisson.

Les plateaux insérés dans le four peuvent se déformer en cours de cuisson. Une fois les plateaux refroidis, les déformations disparaissent.

10.4 Conseils de cuisson

Résultats de cuisson	Cause possible	Solution
Le dessous du gâteau n'est pas suffisamment cuit.	La position de la grille est incorrecte.	Placez le gâteau sur un niveau plus bas.
Le gâteau s'affaisse et devient mou ou plein de grumeaux.	La température du four est trop élevée.	La prochaine fois, réglez une température du four légèrement plus basse.
	Température du four trop élevée et durée de cuisson trop courte.	Réglez une température de cuisson légèrement inférieure et un temps de cuisson plus long la prochaine fois.
Le gâteau est trop sec.	Température de cuisson trop basse.	La prochaine fois, réglez une température du four plus élevée.
	Durée de cuisson trop longue.	La prochaine fois, réduisez le temps de cuisson.
La cuisson du gâteau n'est pas homogène.	Température du four trop élevée et durée de cuisson trop courte.	Réglez une température de cuisson légèrement inférieure et un temps de cuisson plus long la prochaine fois.
	La pâte à gâteau n'est pas correctement répartie.	La prochaine fois, étalez la préparation de façon homogène sur le plateau de cuisson.
Le gâteau n'est pas cuit à la fin de la durée de cuisson indiquée dans la recette.	Température de cuisson trop basse.	La prochaine fois, réglez une température du four légèrement plus élevée.



10.5 Cuisson sur un seul niveau

 CUIS- SON DANS DES MOULES		 (°C)	 (min)	
Fond de tarte - pâte brisée, pré- chauffer le four à vide	Chaleur tournante	170 - 180	10 - 25	2
Fond de tarte - mélange de génoi- se	Chaleur tournante	150 - 170	20 - 25	2
Savarin / Brioche	Chaleur tournante	150 - 160	50 - 70	1
Quatre-quarts / Gâteaux aux fruits	Chaleur tournante	140 - 160	70 - 90	1
Cheesecake	Chauffage Haut/ Bas	170 - 190	60 - 90	1

Utilisez le troisième niveau de la grille.

Utilisez la fonction : Chaleur tournante.





Utilisez un plateau de cuisson.





 GÂTEAUX / PÂTISSERIES / PAINS	 (°C)	 (min)
Gâteau avec garniture à base de crumble	150 - 160	20 - 40
Flans aux fruits (à base de pâte levée/mélange de génoise), utilisez un plat à rôtir	150	35 - 55
Flans aux fruits à base de pâte brisée	160 - 170	40 - 80

Préchauffez le four à vide.





Utilisez la fonction : Chauffage Haut/ Bas.

Utilisez un plateau de cuisson.

 GÂTEAUX / PÂTISSERIES / PAINS	 (°C)	 (min)	
Gâteau roulé	180 - 200	10 - 20	3
Pain de seigle:	d'abord : 230	20	1
	puis : 160 - 180	30 - 60	
Gâteau aux amandes beurré / Gâteaux au sucre	190 - 210	20 - 30	3
Choux à la crème / Éclairs	190 - 210	20 - 35	3





 GÂTEAUX / PÂTISSERIES / PAINS	 (°C)	 (min)	
Pain tressé / Pain en forme de couronne	170 - 190	30 - 40	3
Flans aux fruits (à base de pâte levée/mélange de génoise), utilisez un plat à rôtir	170	35 - 55	3
Gâteaux à pâte levée à garniture fragile (par ex. fromage blanc, crème, crème anglaise)	160 - 180	40 - 80	3
Brioche de Noël	160 - 180	50 - 70	2





Utilisez le troisième niveau de la grille.

 BISCUITS		 (°C)	 (min)
Biscuits à pâte brisée	Chaleur tournante	150 - 160	10 - 20
Petits pains, préchauffer le four à vide	Chaleur tournante	160	10 - 25
Biscuits à base de mélange de génoise	Chaleur tournante	150 - 160	15 - 20
Pâtes feuilletées, préchauffer le four à vide	Chaleur tournante	170 - 180	20 - 30
Biscuits à base de pâte levée	Chaleur tournante	150 - 160	20 - 40
Macarons	Chaleur tournante	100 - 120	30 - 50
Pâtisseries à base de blanc d'œuf / Meringues	Chaleur tournante	80 - 100	120 - 150
Petits pains, préchauffer le four à vide	Chauffage Haut/ Bas	190 - 210	10 - 25

10.6 Gratins

Utilisez le premier niveau de la grille.





		 (°C)	 (min)
Baguettes nappées de fromage fondu	Chaleur tournante	160 - 170	15 - 30
Gratin de légumes, préchauffer le four à vide	Turbo grill	160 - 170	15 - 30





		 (°C)	 (min)
Lasagne	Chauffage Haut/ Bas	180 - 200	25 - 40
Poisson gratiné	Chauffage Haut/ Bas	180 - 200	30 - 60
Légumes farcis	Chaleur tournante	160 - 170	30 - 60
Pâtisseries sucrées	Chauffage Haut/ Bas	180 - 200	40 - 60
Cuisson des pâtes	Chauffage Haut/ Bas	180 - 200	45 - 60

10.7 Cuisson sur plusieurs niveaux

Utilisez la fonction : Chaleur tournante.

Utilisez les plateaux de cuisson.

 GÂTEAUX / PÂTISSERIES	 (°C)	 (min)	 2 positions
Choux à la crème / Éclairs, préchauffer le four à vide	160 - 180	25 - 45	1 / 4
Gâteau Streusel sec	150 - 160	30 - 45	1 / 4

 BIS- CUITS / PETITS GÂTEAUX / VIENNOISE- RIES / ROULÉS	 (°C)	 (min)	 2 positions	 3 positions
Petits pains	180	20 - 30	1 / 4	-
Biscuits à pâte bri- sée	150 - 160	20 - 40	1 / 4	1 / 3 / 5
Biscuits à base de mélange de génoise	160 - 170	25 - 40	1 / 4	-
Pâtes feuilletées, préchauffer le four à vide	170 - 180	30 - 50	1 / 4	-
Biscuits à base de pâte levée	160 - 170	30 - 60	1 / 4	-
Macarons	100 - 120	40 - 80	1 / 4	-
Biscuits à base de blanc d'œuf / Merin- gues	80 - 100	130 - 170	1 / 4	-

10.8 Conseils de rôtissage

Utilisez des plats résistant à la chaleur.

Viande maigre rôtie couverte (vous pouvez utiliser du papier aluminium).

Vous pouvez cuire de gros rôtis directement dans le plat à rôtir ou sur la grille métallique en plaçant le plat à rôtir en dessous.

Pour éviter que les graisses de cuisson ne brûlent, versez un peu d'eau dans le plat à rôtir.







Si nécessaire, retournez le rôti à la moitié ou aux deux tiers du temps de cuisson.







Faites rôtir la viande et le poisson par morceaux d'au moins 1 kg.

Arrosez les morceaux de viande avec leur propre jus de cuisson plusieurs fois durant la cuisson.

10.9 Rôtissage

Utilisez le premier niveau de la grille.

 BŒUF				 (°C)	 (min)
Braisé	1 - 1,5 kg	Chauffage Haut/ Bas		230	120 - 150
Rôti ou filet de bœuf, saignant, préchauffer le four à vide	par cm d'épaisseur	Turbo gril		190 - 200	5 - 6
Rôti ou filet de bœuf, à point, préchauffer le four à vide	par cm d'épaisseur	Turbo gril		180 - 190	6 - 8
Rôti ou filet de bœuf, bien cuit, préchauffer le four à vide	par cm d'épaisseur	Turbo gril		170 - 180	8 - 10

 PORC	 Utilisez la fonction : Turbo gril.				
	 (kg)	 (°C)	 (min)		
Épaule / Cou / Noix de jambon	1 - 1.5	160 - 180	90 - 120		
Côtelettes / Côte levée	1 - 1.5	170 - 180	60 - 90		
Pain de viande	0.75 - 1	160 - 170	50 - 60		
Jarret de porc, pré-cuit	0.75 - 1	150 - 170	90 - 120		



VEAU



Utilisez la fonction : Turbo gril.



(kg)



(°C)



(min)

Rôti de veau

1

160 - 180

90 - 120

Jarret de veau

1.5 - 2

160 - 180

120 - 150



AGNEAU



Utilisez la fonction : Turbo gril.



(kg)



(°C)



(min)

Gigot d'agneau / Rôti
d'agneau

1 - 1.5

150 - 170

100 - 120

Selle d'agneau

1 - 1.5

160 - 180

40 - 60



GIBIER



Utilisez la fonction : Chauffage Haut/ Bas.



(kg)



(°C)



(min)

Selle / Cuisse de lièvre,
préchauffer le four à vide

jusqu'à 1

230

30 - 40

Selle de cerf

1.5 - 2

210 - 220

35 - 40

Cuissot de chevreuil

1.5 - 2

180 - 200

60 - 90



VOLAILLE



Utilisez la fonction : Turbo grill.



(kg)



(°C)



(min)

Volaille, portions	0,2 - 0,25 chacun	200 - 220	30 - 50
Poulet, demi	0,4 - 0,5 chacun	190 - 210	35 - 50
Poulet, poularde	1 - 1,5	190 - 210	50 - 70
Canard	1,5 - 2	180 - 200	80 - 100
Oie	3,5 - 5	160 - 180	120 - 180
Dinde	2,5 - 3,5	160 - 180	120 - 150
Dinde	4 - 6	140 - 160	150 - 240



POISSON (À LA VAPEUR)



Utilisez la fonction : Chauffage Haut/ Bas.



(kg)



(°C)



(min)

Poisson entier	1 - 1,5	210 - 220	40 - 60
----------------	---------	-----------	---------

10.10 Cuisson croustillante avec la fonction :Fonction Pizza



PIZZA



Utilisez le premier niveau de la grille.



(°C)



(min)

Tartes	180 - 200	40 - 55
Flan d'épinards	160 - 180	45 - 60
Quiche lorraine / Flan suisse	170 - 190	45 - 55



PIZZA



Utilisez le premier niveau de la grille.



(°C)



(min)

Cheesecake	140 - 160	60 - 90
Tourte aux légumes	160 - 180	50 - 60



PIZZA



Avant la cuisson, faites préchauffer votre four vide.



Utilisez le deuxième niveau de la grille.



(°C)



(min)

Pizza, croûte fine, utilisez un plat à rôtir

200 - 230

15 - 20

Pizza, croûte épaisse

180 - 200

20 - 30

Pain sans levain

230 - 250

10 - 20

Flan à pâte feuilletée

160 - 180

45 - 55

Tarte flambée

230 - 250

12 - 20



PIZZA



Avant la cuisson, faites préchauffer votre four vide.



Utilisez le deuxième niveau de la grille.



(°C)



(min)

Pierogi

180 - 200

15 - 25

10.11 Gril

Avant la cuisson, faites préchauffer votre four vide.

Ne faites griller que des morceaux plats de viande ou de poisson.

Placez un plat au premier niveau pour récupérer les graisses.



GRIL



Utilisez la fonction : Gril



(°C)



(min)
1re face



(min)
2e face



Rôti de bœuf

210 - 230

30 - 40

30 - 40

2

Filet de bœuf

230

20 - 30

20 - 30

3

Longe de porc

210 - 230

30 - 40

30 - 40

2

Longe de veau

210 - 230

30 - 40

30 - 40

2

Selle d'agneau

210 - 230

25 - 35

20 - 25

3

Poisson entier, 0,5 kg - 1 kg

210 - 230

15 - 30

15 - 30

3 / 4

10.12 Plats surgelés



DÉCONGÉLATION



Utilisez la fonction : Chaleur tournante.



(°C)



(min)



	(°C)	(min)	
Pizza, surgelée	200 - 220	15 - 25	2
Pizza épaisse, surgelée	190 - 210	20 - 25	2
Pizza, fraîche	210 - 230	13 - 25	2
Bouchées de pizza, surgelées	180 - 200	15 - 30	2
Frites, fines	200 - 220	20 - 30	3
Frites, épaisses	200 - 220	25 - 35	3
Quartiers / Croquettes	220 - 230	20 - 35	3
Rôtis	210 - 230	20 - 30	3
Lasagne / Cannellonis, frais	170 - 190	35 - 45	2
Lasagne / Cannellonis, surgelés	160 - 180	40 - 60	2
Fromage cuit au four	170 - 190	20 - 30	3
Ailes de poulet	190 - 210	20 - 30	2

10.13 Décongélation

Retirez l'emballage des aliments puis placez-les dans une assiette.

Ne couvrez pas les aliments car cela peut rallonger le temps de décongélation.

Pour les grosses quantités d'aliments, placez une assiette vide retournée au fond de la

Utilisez le premier niveau de la grille.

cavité. Placez les aliments dans un plat creux, et posez le tout sur l'assiette retournée dans le four. Retirez les supports de grille si nécessaire.



(kg)



(min)

Temps de décongélation



(min)

Temps de décongélation supplémentaire







Poulet

1

100 - 140

20 - 30

Retournez à la moitié du temps.

	 (kg)	 (min) Temps de décon- gélation	 (min) Temps de décon- gélation supplé- mentaire	
Viande	1	100 - 140	20 - 30	Retournez à la moitié du temps.
Truite	0,15	25 - 35	10 - 15	-
Fraises	0,3	30 - 40	10 - 20	-
Beurre	0,25	30 - 40	10 - 15	-
Crème	2 x 0,2	80 - 100	10 - 15	La crème fraîche peut être battue même si elle n'est pas complètement décongelée.
Gâteau	1,4	60	60	-

10.14 Stérilisation

Utilisez la fonction Cuisson de sole.

Utilisez toujours des bocaux à stériliser de dimensions identiques, disponibles dans le commerce.

N'utilisez pas de bocaux à couvercles à visser ou à baïonnette, ni de boîtes métalliques.

Utilisez le premier niveau de la grille.

Ne mettez pas plus de six bocaux à conserves d'un litre sur le plateau de cuisson.



Remplissez les bocaux au même niveau et enclenchez le système de fermeture.

Les bocaux ne doivent pas se toucher.



Mettez environ 1/2 litre d'eau dans le plateau de cuisson pour humidifier le four.

Lorsque le liquide contenu dans les pots commence à frémir (au bout d'environ 35 à 60 minutes pour des pots d'un litre), éteignez le four ou réduisez la température à 100 °C (reportez-vous au tableau).



Réglez la température sur 160 - 170 °C.

 **BAIES** 
(min)
Cuisson jusqu'à ce que la préparation commence à frémir

Fraises / Myrtilles / Framboises / Groseilles à maquereau mûres 35 - 45

 **FRUITS À NOYAU**  (min)  (min)
Cuisson jusqu'à ce que la préparation commence à frémir **Continuez la cuisson à 100 °C**

Pêches / Coings / Prunes 35 - 45 10 - 15

 LÉ- GUMES	 (min) Cuisson jus- qu'à ce que la prépara- tion com- mence à fré- mir	 (min) Continuez la cuisson à 100 °C
Carottes	50 - 60	5 - 10
Concombres	50 - 60	-
Cornichons mé- langés	50 - 60	5 - 10
Chou-rave / Pe- tits pois / Asper- ges	50 - 60	15 - 20

10.15 Déshydratation - Chaleur tournante

Utilisez des plaques recouvertes de papier sulfurisé.

Pour obtenir un meilleur résultat, arrêtez le four à la moitié de la durée de déshydratation, ouvrez la porte et laissez refroidir pendant une nuit pour terminer le séchage.

10.16 Chaleur tournante humide - accessoires recommandés

Utilisez les moules et récipients foncés et non réfléchissants. Ils offrent une meilleure absorption de la chaleur que les plats réfléchissants de couleur claire.



Plaque à pizza

Sombre, non réfléchissant
Diamètre de 28 cm

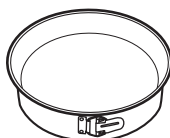

Plat de cuisson

Sombre, non réfléchissant
Diamètre de 26 cm



Ramequins

Céramique
8 cm de diamètre,
5 cm de hauteur

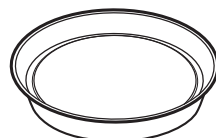

Moule pour fond de tarte



Sombre, non réfléchissant
Diamètre de 28 cm

10.17 Chaleur tournante humide



Pour de meilleurs résultats, suivez les suggestions indiquées dans le tableau ci-dessous.





Pour une plaque, utilisez le troisième niveau de la grille.

Pour deux plaques, utilisez les premier et quatrième niveaux de la grille.

 LÉGUMES	 (°C)	 (h)
Haricots	60 - 70	6 - 8
Poivrons	60 - 70	5 - 6
Légumes pour soupe	60 - 70	5 - 6
Champignons	50 - 60	6 - 8
Herbes	40 - 50	2 - 3







Réglez la température sur 60 - 70 °C.







 FRUITS	 (h)
Prunes	8 - 10
Abricots	8 - 10
Tranches de pommes	6 - 8
Poires	6 - 9

	 (°C)	 (min)	
Gressins, 0,5 kg au total	190 - 200	50 - 60	3
Coquilles Saint-Jacques cuites au four	180 - 200	30 - 40	4
Poisson entier en sel, 0,3 - 0,5 kg	190 - 200	45 - 50	4
Poisson entier en papier sulfurisé, 0,3 - 0,5 kg	190 - 200	50 - 60	3
Amaretti (20 ; 0,5 kg au total)	170 - 180	40 - 50	3
Crumble aux pommes	190 - 200	50 - 60	4
Muffins au chocolat (20 ; 0,5 kg au total)	160 - 170	35 - 45	3

10.18 Informations pour les instituts de test

Tests conformes aux normes : EN 60350, IEC 60350.

 CUISSON SUR UN SEUL NIVEAU. Cuisson dans des moules				
		 (°C)	 (min)	
Génoise allégée	Chaleur tournante	140 - 150	35 - 50	2
Génoise allégée	Chauffage Haut/ Bas	160	35 - 50	2
Tourte aux pommes, 2 moules Ø20 cm	Chaleur tournante	160	60 - 90	2
Tourte aux pommes, 2 moules Ø20 cm	Chauffage Haut/ Bas	180	70 - 90	1

 CUISSON SUR UN SEUL NIVEAU. Biscuits/Gâteaux secs				
 Utilisez le troisième niveau de la grille.				
		 (°C)	 (min)	
Sablé / Lamelles de pâtisserie	Chaleur tournante	140	25 - 40	
Sablé / Lamelles de pâtisserie, préchauffer le four à vide	Chauffage Haut/ Bas	160	20 - 30	



CUISSON SUR UN SEUL NIVEAU. Biscuits/Gâteaux secs



Utilisez le troisième niveau de la grille.



(°C)



(min)

Petits gâteaux, 20 par plateau,
préchauffer le four à vide

Chaleur tournante

150

20 - 35

Petits gâteaux, 20 par plateau,
préchauffer le four à vide

Chauffage Haut/ Bas

170

20 - 30



CUISSON SUR PLUSIEURS NIVEAUX. Biscuits/Gâteaux secs



(°C)



(min)



Sablé / Lamelles de pâtisserie

Chaleur tournante

140

25 - 45

1 / 4

Petits gâteaux, 20 par plateau,
préchauffer le four à vide

Chaleur tournante

150

23 - 40

1 / 4

Génoise allégée

Chaleur tournante

160

35 - 50

1 / 4



GRIL



Préchauffez toujours le four à vide pendant 5 minutes.



Réglez le gril à la température maximale.



(min)



Toasts

Gril

1 - 3

5

Steak de bœuf, tourner à mi-cuis-
son

Gril

24 - 30

4

11. ENTRETIEN ET NETTOYAGE



AVERTISSEMENT!

Reportez-vous aux chapitres
concernant la sécurité.

11.1 Remarques concernant l'entretien



Agents nettoyants

Nettoyez la façade du four avec un chiffon doux, de l'eau tiède et un détergent doux.

Utilisez une solution de nettoyage pour nettoyer les surfaces métalliques.

Nettoyez les taches avec un détergent doux.



Utilisation quotidienne

Nettoyez la cavité après chaque utilisation. L'accumulation de graisse ou d'autres résidus peut provoquer un incendie.

Ne conservez pas les aliments dans le four pendant plus de 20 minutes. Sécher la cavité avec un chiffon doux après chaque utilisation.



Accessoires

Après chaque utilisation, lavez tous les accessoires et séchez-les. Utilisez un chiffon doux avec de l'eau tiède et un détergent doux. Ne lavez pas les accessoires au lave-vaisselle.

Ne nettoyez pas les accessoires antiadhésifs avec un produit nettoyant abrasif ou des objets tranchants.

11.2 Comment enlever : Supports de grille

Retirez les supports de grille pour nettoyer le four.

Étape 1 Éteignez le four et attendez qu'il soit froid.

Étape 2 Écartez l'avant du support de grille de la paroi latérale.

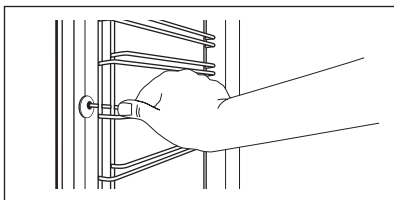

Étape 3 Écartez l'arrière du support de grille de la paroi latérale et retirez le support.

Étape 4 Réinstallez les supports de grille en répétant cette procédure dans l'ordre inverse.

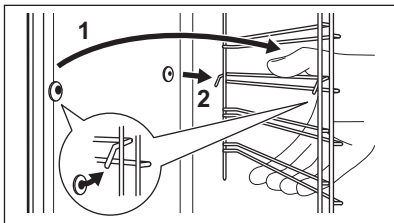

11.3 Comment enlever : Gril



AVERTISSEMENT!

Risque de brûlure !

Étape 1 Éteignez le four et attendez qu'il soit froid pour le nettoyer.
Retirez les supports de grille.

Étape 2 Saisissez les coins de la grille. Tirez-la vers l'avant en surmontant la pression du ressort et sortez-la des deux supports. Le gril se replie.

Étape 3 Nettoyez la voûte du four avec de l'eau chaude, un chiffon doux et un détergent doux. Laissez-la sécher.

Étape 4 Installez le gril selon la même procédure, mais dans l'ordre inverse.

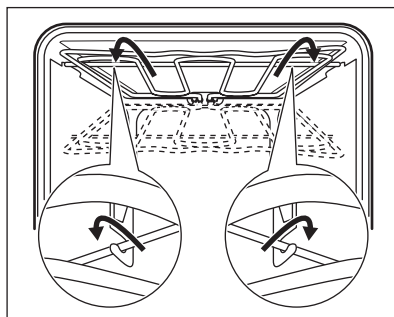

Étape 5 Installez les supports de grille.

11.4 Comment démonter et installer :

Le nombre de panneaux en verre varie selon les modèles.



ATTENTION!

Manipulez soigneusement la vitre, en particulier autour des bords du panneau avant. Elles pourraient se briser.

11.5 Comment remplacer : Éclairage



AVERTISSEMENT!

Risque d'électrocution.
L'éclairage peut être chaud.

Avant de remplacer l'éclairage :

Étape 1

Éteignez le four. Attendez que le four ait refroidi.

Étape 2

Débranchez le four de l'alimentation secteur.

Étape 3

Placez un chiffon au fond de la cavité.

Lampe supérieure

Étape 1 Tournez le diffuseur en verre pour le retirer.

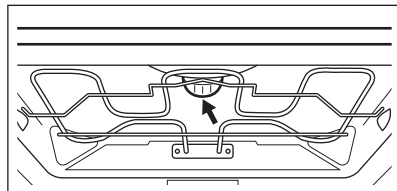

Étape 2 Nettoyez le diffuseur en verre.

Étape 3 Remplacez l'éclairage par une ampoule adaptée résistant à une température de 300 °C.

Étape 4 Remettez en place le diffuseur en verre.

12. DÉPANNAGE



AVERTISSEMENT!

Reportez-vous aux chapitres concernant la sécurité.

12.1 Que faire si...

Dans tous les cas ne figurant pas dans ce tableau, veuillez contacter un service après-vente agréé.

Problème	Vérifiez si...
Le four ne chauffe pas.	Le fusible a disjoncté.
L'affichage indique « 12.00 ».	Une coupure de courant s'est produite. Pour régler l'heure.

Problème

Vérifiez si...

L'éclairage ne fonctionne pas. L'ampoule est grillée.

12.2 Données de maintenance

Si vous ne trouvez pas de solution au problème, veuillez contacter votre revendeur ou un service après-vente agréé.

Les informations à fournir au service après-vente figurent sur la plaque signalétique. La plaque signalétique se trouve sur l'encadrement avant de la cavité du four. Ne retirez pas la plaque signalétique de la cavité du four.

Nous vous recommandons de noter ces informations ici :

Modèle (MOD.)

Référence du produit (PNC)

Numéro de série (S.N.)

13. RENDEMENT ÉNERGÉTIQUE

13.1 Informations produit et Fiche d'informations produit*

Nom du fournisseur	AEG
Identification du modèle	BEK435220M 944188023
Index d'efficacité énergétique	81.2
Classe d'efficacité énergétique	A+
Consommation d'énergie avec charge standard et mode traditionnel	0.99 kWh/cycle
Consommation d'énergie avec charge standard et mode air pulsé	0.69 kWh/cycle
Nombre de cavités	1
Source de chaleur	Électricité
Volume	71 l
Type de four	Four encastrable
Masse	34.0 kg

* Pour l'Union européenne conformément aux Règlements UE 65/2014 et 66/2014.
Pour la République de Biélorussie conformément à STB 2478-2017, Annexe G ; STB 2477-2017, Annexes A et B.
Pour l'Ukraine conformément à 568/32020.

La classe d'efficacité énergétique n'est pas applicable pour la Russie.

EN 60350-1 - Appareils de cuisson domestiques électriques - Partie 1 : Plages, fours, fours à vapeur et grils - Méthodes de mesure des performances.

13.2 Économie d'énergie



Ce four est doté de caractéristiques qui vous permettent d'économiser de l'énergie lors de votre cuisine au quotidien.

Veillez à ce que la porte du four soit fermée lorsqu'il fonctionne. N'ouvrez pas la porte du four trop souvent pendant la cuisson. Gardez le joint de porte propre et veillez à ce qu'il soit bien fixé en place.

Utilisez des plats en métal pour accroître les économies d'énergie.

Si possible, ne préchauffez pas le four avant la cuisson.

Lorsque vous cuisez plusieurs plats les uns après les autres, veillez à ne pas trop espacer les cuissons.

Cuisson avec ventilation

Si possible, utilisez les fonctions de cuisson avec la ventilation pour économiser de l'énergie.

Chaleur résiduelle

Si la cuisson doit durer plus de 30 minutes, réduisez la température du four au minimum 3 à 10 minutes avant la fin de la cuisson. La chaleur résiduelle à l'intérieur du four poursuivra la cuisson.

Utilisez la chaleur résiduelle pour réchauffer d'autres plats.

Maintien des aliments au chaud

Sélectionnez la température la plus basse possible pour utiliser la chaleur résiduelle et maintenir le repas au chaud.

Chaleur tournante humide

Fonction conçue pour économiser de l'énergie en cours de cuisson.

14. EN MATIÈRE DE PROTECTION DE L'ENVIRONNEMENT

Recyclez les matériaux portant le symbole



Déposez les emballages dans les conteneurs prévus à cet effet. Contribuez à la protection de l'environnement et à votre sécurité, recyclez vos produits électriques et électroniques. Ne jetez pas les appareils

portant le symbole  avec les ordures ménagères. Emmenez un tel produit dans votre centre local de recyclage ou contactez vos services municipaux.

FÜR PERFEKTE ERGEBNISSE

Danke, dass Sie sich für dieses AEG Produkt entschieden haben. Wir haben es geschaffen, damit Sie viele Jahre von seiner ausgezeichneten Leistung und den innovativen Technologien, die Ihnen das Leben erleichtern, profitieren können. Es ist mit Funktionen ausgestattet, die in gewöhnlichen Geräten nicht vorhanden sind. Nehmen Sie sich ein paar Minuten Zeit zum Lesen, um seine Vorzüge kennen zu lernen.

Besuchen Sie uns auf unserer Website, um:



Anwendungshinweise, Prospekte, Fehlerbehebungs-, Service- und Reparatur-Informationen zu erhalten:

www.aeg.com/support



Ihr erworbenes Produkt zu registrieren, um den besten Service für es zu gewährleisten:

www.registreaeg.com



Zubehör, Verbrauchsmaterial und Original-Ersatzteile für Ihr Gerät zu erwerben:

www.aeg.com/shop

REPARATUR- UND KUNDENDIENST

Verwenden Sie ausschließlich Original-Ersatzteile.

Halten Sie folgende Angaben bereit, wenn Sie sich an den Kundendienst wenden:

Modell, Produktnummer (PNC), Seriennummer.

Diese Informationen finden Sie auf dem Typenschild.

 Warnungs-/Sicherheitshinweise

 Allgemeine Informationen und Empfehlungen

 Informationen zum Umweltschutz

Änderungen vorbehalten.

INHALTSVERZEICHNIS

1. SICHERHEITSHINWEISE.....	56
2. SICHERHEITSHINWEISEN.....	58
3. GERÄTEBESCHREIBUNG.....	61
4. BEDIENFELD.....	62
5. VOR DER ERSTEN INBETRIEBNAHME.....	62
6. TÄGLICHER GEBRAUCH.....	63
7. UHRFUNKTIONEN.....	64
8. VERWENDUNG DES ZUBEHÖRS.....	65
9. ZUSATZFUNKTIONEN.....	66
10. TIPPS UND HINWEISE.....	66
11. REINIGUNG UND PFLEGE.....	78
12. FEHLERSUCHE.....	81
13. ENERGIEEFFIZIENZ.....	81

1. SICHERHEITSHINWEISE

Lesen Sie vor der Montage und dem Gebrauch des Geräts zuerst die Bedienungsanleitung. Bei Verletzungen oder

Schäden infolge nicht ordnungsgemäßer Montage oder Verwendung übernimmt der Hersteller keine Haftung. Bewahren Sie die Anleitung zum Nachschlagen an einem sicheren und zugänglichen Ort auf.

1.1 Sicherheit von Kindern und schutzbedürftigen Personen

- Das Gerät kann von Kindern ab 8 Jahren und Personen mit eingeschränkten physischen, sensorischen oder geistigen Fähigkeiten oder mit mangelnder Erfahrung und/oder mangelndem Wissen nur dann verwendet werden, wenn sie durch eine für ihre Sicherheit zuständige Person beaufsichtigt werden oder in die sichere Verwendung des Geräts eingewiesen wurden und die mit dem Gerät verbundenen Gefahren verstanden haben. Kinder unter 8 Jahren und Personen mit schweren Behinderungen oder Mehrfachbehinderung müssen vom Gerät ferngehalten werden, wenn sie nicht ständig beaufsichtigt werden.
- Kinder dürfen nicht mit dem Gerät spielen.
- Halten Sie sämtliches Verpackungsmaterial von Kindern fern und entsorgen Sie es ordnungsgemäß.
- **WARNUNG:** Halten Sie Kinder und Haustiere während des Betriebs oder der Abkühlphase vom Gerät fern. Die zugänglichen Geräteteile werden beim Betrieb sehr heiß.
- Falls Ihr Gerät mit einer Kindersicherung ausgestattet ist, empfehlen wir, diese einzuschalten.
- Kinder dürfen keine Reinigung und Wartung ohne Beaufsichtigung durchführen.

1.2 Allgemeine Sicherheit

- Die Montage des Geräts und der Austausch des Kabels muss von einer Fachkraft vorgenommen werden.
- **WARNUNG:** Das Gerät und die zugänglichen Geräteteile werden während des Betriebs heiß. Seien Sie vorsichtig und berühren Sie niemals die Heizelemente.
- Verwenden Sie zum Anfassen des Zubehörs und der Töpfe wärmeisolierende Handschuhe.

- Ziehen Sie bitte vor jeder Wartungsmaßnahme den Netzstecker aus der Steckdose.
- **WARNUNG:** Vergewissern Sie sich, dass das Gerät ausgeschaltet ist, bevor Sie die Lampe austauschen, um einen Stromschlag zu vermeiden.
- Verwenden Sie das Gerät nicht, bevor es in den Einbauschrank gesetzt wird.
- Reinigen Sie das Gerät nicht mit einem Dampfstrahlreiniger.
- Benutzen Sie keine scharfe Scheuermittel oder Metallschwämmchen zum Reinigen der Glastür; sie können die Glasfläche verkratzen und zum Zersplittern der Scheibe führen.
- Wenn das Netzkabel beschädigt ist, muss es vom Hersteller, seinem autorisierten Kundenservice oder einer gleichermaßen qualifizierten Person ausgetauscht werden, um Gefahren durch elektrischen Strom zu vermeiden.
- Ziehen Sie die Einhängegitter erst vorne und dann hinten von der Seitenwand weg und nehmen Sie sie heraus. Führen Sie zum Einsetzen der Einhängegitter die oben aufgeführten Schritte in umgekehrter Reihenfolge durch.

2. SICHERHEITSANWEISUNGEN

2.1 Montage



WARNUNG!

Die Montage des Geräts darf nur von einer qualifizierten Fachkraft durchgeführt werden.

- Entfernen Sie das gesamte Verpackungsmaterial.
- Montieren Sie ein beschädigtes Gerät nicht und benutzen Sie es nicht.
- Halten Sie sich an die mitgelieferte Montageanleitung.
- Seien Sie beim Umsetzen des Gerätes vorsichtig, da es sehr schwer ist. Tragen Sie stets Sicherheitshandschuhe und festes Schuhwerk.
- Ziehen Sie das Gerät nicht am Griff.
- Montieren Sie das Gerät an einem sicheren und geeigneten Ort, der den Montageanforderungen entspricht.

- Die Mindestabstände zu anderen Geräten und Küchenmöbeln sind einzuhalten.
- Überprüfen Sie vor der Montage des Gerätes, ob sich die Ofentür ohne Kraftanwendung öffnen lässt.
- Das Gerät ist mit einem elektrischen Kühlsystem ausgestattet. Es muss an die Stromversorgung angeschlossen werden.
- Die Standsicherheit des Küchenmöbels muss DIN 68930 entsprechen.

Mindesthöhe des Einbaumöbels (Mindesthöhe des Schrankes unter der Arbeitsplatte) 578 (600) mm

Schrankbreite 560 mm

Schranktiefe 550 (550) mm

Höhe der Gerätevorderseite	594 mm
Höhe der Geräterückseite	576 mm
Breite der Gerätevorderseite	595 mm
Breite der Geräterückseite	559 mm
Gerätetiefe	567 mm
Geräteeinbautiefe	546 mm
Tiefe bei geöffneter Tür	1027 mm
Mindestgröße der Belüftungsöffnung. Öffnung auf der Rückseite unten	560 x 20 mm
Länge des Netzanschlusskabels. Das Kabel befindet sich in der rechten Ecke auf der Rückseite.	1500 mm
Befestigungsschrauben	4 x 25 mm

2.2 Elektroanschluss



WARNUNG!

Brand- und Stromschlaggefahr.

- Alle elektrischen Anschlüsse sind von einem geprüften Elektriker vorzunehmen.
- Das Gerät muss geerdet sein.
- Stellen Sie sicher, dass die Daten auf dem Typenschild mit den elektrischen Nennwerten der Netzspannung übereinstimmen.
- Schließen Sie das Gerät nur an eine ordnungsgemäß installierte Schutzkontaktsteckdose an.
- Verwenden Sie keine Mehrfachsteckdosen oder Verlängerungskabel.
- Achten Sie darauf, Netzstecker und Netzkabel nicht zu beschädigen. Falls das Netzkabel des Geräts ersetzt werden muss, lassen Sie diese Arbeit durch unseren autorisierten Kundendienst durchführen.
- Achten Sie darauf, dass das Netzkabel die Gerätetür oder die Nische unter dem Gerät nicht berührt oder in ihre Nähe gelangt, insbesondere wenn das Gerät eingeschaltet oder die Tür heiß ist.
- Alle Teile, die gegen direktes Berühren schützen, sowie die isolierten Teile müssen so befestigt werden, dass sie

nicht ohne Werkzeug entfernt werden können.

- Stecken Sie den Netzstecker erst nach Abschluss der Montage in die Steckdose. Stellen Sie sicher, dass der Netzstecker nach der Montage noch zugänglich ist.
- Falls die Steckdose lose ist, schließen Sie den Netzstecker nicht an.
- Ziehen Sie nicht am Netzkabel, wenn Sie das Gerät von der Stromversorgung trennen möchten. Ziehen Sie stets am Netzstecker.
- Verwenden Sie nur geeignete Trenneinrichtungen: Überlastschalter, Sicherungen (Schraubsicherungen müssen aus dem Halter entfernt werden können), Fehlerstromschutzschalter und Schütze.
- Die elektrische Installation muss eine Trenneinrichtung aufweisen, mit der Sie das Gerät allpolig von der Stromversorgung trennen können. Die Trenneinrichtung muss mit einer Kontaktöffnungsweite von mindestens 3 mm ausgeführt sein.
- Das Gerät wird mit einem Netzstecker und Netzkabel geliefert.

2.3 Bedienung



WARNUNG!

Verletzungs-, Verbrennungs-, Stromschlag- oder Explosionsgefahr.

- Dieses Gerät ist ausschließlich zur Verwendung im Haushalt bestimmt.
- Nehmen Sie keine technischen Änderungen am Gerät vor.
- Die Lüftungsöffnungen dürfen nicht abgedeckt werden.
- Lassen Sie das Gerät bei Betrieb nicht unbeaufsichtigt.
- Schalten Sie das Gerät nach jedem Gebrauch aus.
- Gehen Sie beim Öffnen der Tür vorsichtig vor, wenn das Gerät in Betrieb ist. Es kann heiße Luft austreten.
- Bedienen Sie das Gerät nicht mit feuchten oder nassen Händen oder wenn es mit Wasser in Kontakt gekommen ist.
- Üben Sie keinen Druck auf die geöffnete Gerätetür aus.
- Benutzen Sie das Gerät nicht als Arbeits- oder Abstellfläche.

- Öffnen Sie die Gerätetür vorsichtig. Bei der Verwendung von Zutaten, die Alkohol enthalten, kann ein Alkohol-Luftgemisch entstehen.
- Achten Sie beim Öffnen der Tür darauf, dass keine Funken oder offenen Flammen in das Gerät gelangen.
- Laden Sie keine entflammaren Produkte oder Gegenstände, die mit entflammaren Produkten benetzt sind, in das Gerät und stellen Sie solche nicht in die Nähe oder auf das Gerät.



WARNUNG!

Risiko von Schäden am Gerät.

- Um Beschädigungen und Verfärbungen der Emailbeschichtung zu vermeiden:
 - Stellen Sie feuerfestes Geschirr oder andere Gegenstände nicht direkt auf den Boden des Geräts.
 - Legen Sie keine Alufolie direkt auf den Boden des Garraums.
 - Füllen Sie kein Wasser in das heiße Gerät.
 - Lassen Sie nach Abschluss des Garvorgangs kein feuchtes Geschirr oder feuchte Speisen im Gerät stehen.
 - Gehen Sie beim Herausnehmen oder Einsetzen des Zubehörs sorgfältig vor.
- Verfärbungen der Email- oder Edelstahlbeschichtung haben keine Auswirkung auf die Leistung des Geräts.
- Verwenden Sie für feuchte Kuchen das tiefe Blech. Fruchtsäfte können bleibende Flecken verursachen.
- Dieses Gerät ist nur zum Kochen bestimmt. Jeder andere Gebrauch ist als bestimmungsfremd anzusehen, zum Beispiel das Beheizen eines Raums.
- Die Backofentür muss beim Betrieb geschlossen sein.
- Ist das Gerät hinter einer Möbelfront (z. B. einer Tür) installiert, achten Sie darauf, dass die Tür während des Gerätebetriebs nicht geschlossen wird. Hinter einer geschlossenen Möbelfront können sich Hitze und Feuchtigkeit ansammeln und das Gerät, Gehäuse oder den Boden beschädigen. Schließen Sie die Möbelfront nicht, bevor das Gerät nach dem Gebrauch vollständig abgekühlt ist.

2.4 Reinigung und Pflege



WARNUNG!

Verletzungs-, Brandgefahr sowie Risiko von Schäden am Gerät.

- Schalten Sie das Gerät immer aus und ziehen Sie den Netzstecker aus der Steckdose, bevor Reinigungsarbeiten durchgeführt werden.
- Vergewissern Sie sich, dass das Gerät abgekühlt ist. Es besteht die Gefahr, dass die Glasscheiben brechen.
- Ersetzen Sie die Türglasscheiben umgehend, wenn sie beschädigt sind. Wenden Sie sich an einen autorisierten Kundendienst.
- Reinigen Sie das Gerät regelmäßig, um eine Verschlechterung des Oberflächenmaterials zu verhindern.
- Reinigen Sie das Geräts mit einem weichen, feuchten Tuch. Verwenden Sie ausschließlich Neutralreiniger. Benutzen Sie keine Scheuermittel, scheuernde Reinigungsschwämmchen, Lösungsmittel oder Metallgegenstände.
- Falls Sie ein Backofenspray verwenden, befolgen Sie die Sicherheitsanweisungen auf seiner Verpackung.

2.5 Innenbeleuchtung



WARNUNG!

Stromschlaggefahr.

- Bezüglich der Lampe(n) in diesem Gerät und separat verkaufter Ersatzlampen: Diese Lampen müssen extremen physikalischen Bedingungen in Haushaltsgeräten standhalten, wie z.B. Temperatur, Vibration, Feuchtigkeit, oder sollen Informationen über den Betriebszustand des Gerätes anzeigen. Sie sind nicht für den Einsatz in anderen Geräten vorgesehen und nicht für die Raumbeleuchtung geeignet.
- Verwenden Sie nur Lampen mit der gleichen Leistung .

2.6 Service

- Wenden Sie sich zur Reparatur des Geräts an den autorisierten Kundendienst.
- Verwenden Sie ausschließlich Originalersatzteile.

2.7 Entsorgung



WARNUNG!

Verletzungs- und Erstickungsgefahr.

- Trennen Sie das Gerät von der Stromversorgung.

- Schneiden Sie das Netzkabel in der Nähe des Geräts ab, und entsorgen Sie es.
- Entfernen Sie das Türschloss, um zu verhindern, dass sich Kinder oder Haustiere im Gerät einschließen.

3. GERÄTEBESCHREIBUNG

3.1 Gesamtansicht

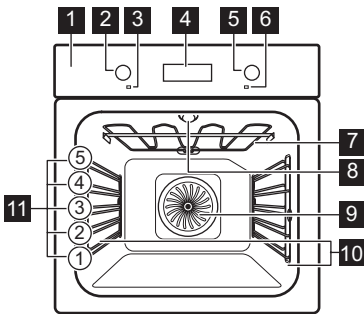

- 1** Bedienblende
- 2** Einstellknopf für die Ofenfunktionen
- 3** Betriebskontrolllampe/-symbol
- 4** Elektronischer Programmspeicher Display
- 5** Einstellknopf (für die Temperatur)
- 6** Temperaturanzeige/-symbol
- 7** Heizelement
- 8** Lampe
- 9** Ventilator
- 10** Einhängeschienen, herausnehmbar
- 11** Einschubebenen

3.2 Zubehör

Kombirost

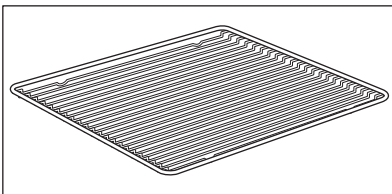

Für Kochgeschirr, Kuchenformen, Braten.

Backblech

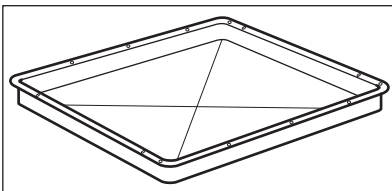

Für Kuchen und Plätzchen.

Brat- und Fettpfanne

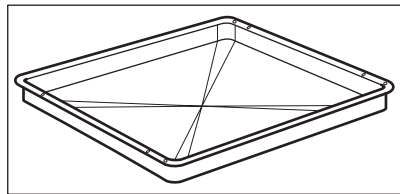

Zum Backen und Braten oder zum Auffangen von abtropfendem Fett.

4. BEDIENFELD

4.1 Versenkbare Knöpfe

Drücken Sie zum Benutzen des Geräts den Knopf. Der Knopf kommt dann heraus.

4.2 Sensorfelder/Tasten

—	Einstellen der Zeit.
⌚	Einstellen einer Uhrfunktion.
+	Einstellen der Zeit.

4.3 Display

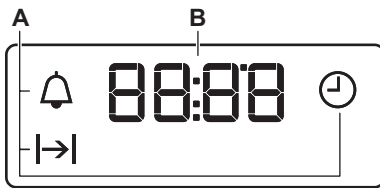

- A. Uhrfunktionen
- B. Timer

5. VOR DER ERSTEN INBETRIEBNAHME



WARNUNG!

Siehe Kapitel
Sicherheitshinweise.

5.1 Vor der ersten Inbetriebnahme

Der Backofen kann während des Vorheizens Geruch und Rauch verströmen. Stellen Sie sicher, dass der Raum belüftet ist.



Schritt 1

Stellen Sie die Uhrzeit ein











Schritt 2

Reinigen Sie den Backofen



Schritt 3

Heizen Sie den leeren Backofen
vor

- | | | |
|------------------------------------------------------------------------------------------------------------------------------------------------------------------------------------------------------------------------------------------------------------------------------------------------------------------------------------------------------------------------------------------------------------------------------------------------------------------------------------------------------------------------------------------------------------------------------------------------------------------------------------------------------------------------------------------------------------------------------------------------------------------------------------------------|----------------------------------------------------------------------------------------------------------------------------------------------------------------------------------------------------------------------------------------------------------------------------------------------|---------------------------------------------------------------------------------------------------------------------------------------------------------------------------------------------------------------------------------------------------------------------------------------------------------------------------------------------------------------------------------------------------|
| <ol style="list-style-type: none"> 1. Drücken Sie:  2. ,  - zum Einstellen der Stunde drücken. Drücken Sie:  3. ,  - zum Einstellen der Minuten drücken. Drücken Sie:  | <ol style="list-style-type: none"> 1. Nehmen Sie die Zubehörteile und die herausnehmbaren Einhängegitter aus dem Ofen. 2. Feuchten Sie ein weiches Tuch mit warmem Wasser und etwas mildem Reinigungsmittel an, und reinigen Sie damit den Backofen und das Zubehör. | <ol style="list-style-type: none"> 1. Stellen Sie die Höchsttemperatur für folgende Funktion ein: 
Dauer: 1 Std. 2. Stellen Sie die Höchsttemperatur für folgende Funktion ein: 
Dauer: 15 Min. |
|------------------------------------------------------------------------------------------------------------------------------------------------------------------------------------------------------------------------------------------------------------------------------------------------------------------------------------------------------------------------------------------------------------------------------------------------------------------------------------------------------------------------------------------------------------------------------------------------------------------------------------------------------------------------------------------------------------------------------------------------------------------------------------------------|----------------------------------------------------------------------------------------------------------------------------------------------------------------------------------------------------------------------------------------------------------------------------------------------|---------------------------------------------------------------------------------------------------------------------------------------------------------------------------------------------------------------------------------------------------------------------------------------------------------------------------------------------------------------------------------------------------|

Schalten Sie den Ofen aus und warten Sie, bis er abgekühlt ist. Setzen Sie die Zubehörteile und die herausnehmbaren Einhängegitter in den Backofen.

6. TÄGLICHER GEBRAUCH





WARNUNG!







Siehe Kapitel Sicherheitshinweise.

6.1 Einstellung: Ofenfunktion

- Schritt 1** Drehen Sie den Backofen-Einstellknopf auf eine Ofenfunktion.
- Schritt 2** Drehen Sie den Wahlknopf, um die Temperatur auszuwählen.
- Schritt 3** Drehen Sie nach Beendigung des Gargvorgangs die Knöpfe in die Aus-Position, um den Backofen auszuschalten.

6.2 Ofenfunktionen

Ofenfunktion	Anwendung
0 Stellung Aus	Der Backofen ist ausgeschaltet.
 Backofenbeleuchtung	Einschalten der Lampe.
 Heißluft	Zum Backen auf bis zu drei Einschubebenen gleichzeitig und zum Dörren von Lebensmitteln. Stellen Sie eine 20 - 40 °C niedrigere Backofentemperatur als bei Ober-/Unterhitze ein.

Ofenfunktion	Anwendung
 Pizzastufe	Zum Backen von Pizza. Für ein intensives Überbacken und einen knusprigen Boden.
 Ober-/Unterhitze	Zum Backen und Braten auf einer Ebene.
 Unterhitze	Zum Backen von Kuchen mit knusprigen Böden und zum Einkochen von Lebensmitteln.
 Auftauen	Zum Auftauen von Lebensmitteln (Gemüse und Obst). Die Auftauzeit hängt ab von der Menge und Größe der Tiefkühlgerichte.
 Feuchte Umluft	Diese Funktion ist entwickelt worden, um während des Gargvorgangs Energie zu sparen. Wenn Sie diese Funktion nutzen, kann die Temperatur im Garraum von der eingestellten Temperatur abweichen. Es wird die Restwärme genutzt. Die Wärmeleistung kann geringer sein. Weitere Informationen zu folgenden Themen finden Sie im Kapitel „Täglicher Gebrauch“: Feuchte Umluft.
 Grill	Zum Grillen dünner Lebensmittel und zum Toasten von Brot.

Ofenfunktion	Anwendung
 Heißluftgrillen	Zum Braten großer Fleischstücke oder von Geflügel mit Knochen auf einer Ebene. Zum Grillen und Überbacken.

 Die Lampe wird bei einigen Ofenfunktionen und einer Temperatur unter 60 °C automatisch ausgeschaltet.

6.3 Hinweise zu: Feuchte Umluft

Diese Funktion wurde zur Bestimmung der Energieeffizienzklasse und den



Anforderungen an die umweltgerechte Gestaltung EU 65/2014 und EU 66/2014 verwendet. Tests gemäß EN 60350-1.

Die Backofentür sollte während des Garvorgangs geschlossen bleiben, damit die Funktion nicht unterbrochen wird. So wird gewährleistet, dass der Backofen mit der höchsten Energieeffizienz arbeitet.

Die Kochanleitungen finden Sie im Kapitel "Hinweise und Tipps", Feuchte Umluft. Allgemeine Empfehlungen zur Energieeinsparung finden Sie im Kapitel „Energieeffizienz“, Energie sparen.

7. UHRFUNKTIONEN



7.1 Uhrfunktionen

Uhrfunktion	Anwendung
 Uhrzeit	Zum Einstellen, Ändern oder Abfragen der Uhrzeit.
 Dauer	Einstellen der Einschaltdauer für den Backofen.
 Kurzzeit-Wecker	Zum Einstellen eines Countdowns. Diese Funktion wirkt sich nicht auf den Betrieb des Backofens aus. Sie können diese Funktion jederzeit und auch bei ausgeschaltetem Backofen einstellen.

7.2 Einstellung: Uhrfunktionen

Änderung: Uhrzeit

 blinkt, wenn Sie den Backofen an die Stromversorgung anschließen, nach einem Stromausfall und wenn der Timer nicht eingestellt ist.

Schritt 1  - wiederholt drücken.  - beginnt zu blinken.

Schritt 2 ,  - zum Einstellen der Zeit drücken.
Nach etwa fünf Sekunden hört die Anzeige auf zu blinken und das Display zeigt die Zeit an.



 - wiederholt drücken, um die Tageszeit zu ändern.  - beginnt zu blinken.

Einstellung: Dauer

Schritt 1 Stellen Sie eine Ofenfunktion und die Temperatur ein.

Schritt 2  - wiederholt drücken.  - beginnt zu blinken.



Einstellung: Dauer

Schritt 3  - zum Einstellen der Dauer drücken.
Im Display wird folgendes angezeigt: 
 - blinkt, wenn die eingestellte Zeit abgelaufen ist. Der Signalton ertönt und der Backofen wird ausgeschaltet.

Schritt 4 Drücken Sie eine beliebige Taste, um das Signal abzustellen.

Schritt 5 Drehen Sie die Knöpfe in die Position Aus.

Einstellung: Kurzzeit-Wecker

Schritt 1  - wiederholt drücken.  - beginnt zu blinken.

Schritt 2  - zum Einstellen der Zeit drücken.
Die Funktion startet automatisch nach 5 Sekunden.
Nach Ablauf der eingestellten Zeit ertönt der Signalton.

Schritt 3 Drücken Sie eine beliebige Taste, um das Signal abzustellen.

Schritt 4 Drehen Sie die Knöpfe in die Position Aus.

Abbrechen: Uhrfunktionen

Schritt 1  - wiederholt drücken, bis das Symbol der Uhrfunktion anfängt zu blinken.

Schritt 2 Gedrückt halten: .
Die Uhrfunktion wird nach einigen Sekunden ausgeschaltet.

8. VERWENDUNG DES ZUBEHÖRS



WARNUNG!

Siehe Kapitel
Sicherheitshinweise.

8.1 Einsetzen des Zubehörs

Die kleine Einkerbung auf der Oberseite erhöht die Sicherheit. Diese Einkerbungen

dienen auch als Klipsicherung. Durch den umlaufend erhöhten Rand des Rosts ist das Kochgeschirr gegen Abrutschen vom Rost gesichert.

Kombirost:

Schieben Sie den Kombirost zwischen die Führungsschienen der Einhängegitter.

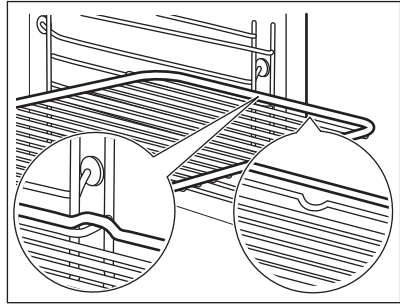
**Backblech /Auflaufpfanne:**

Schieben Sie das Blech zwischen die Führungsstäbe der Einhängegitter.

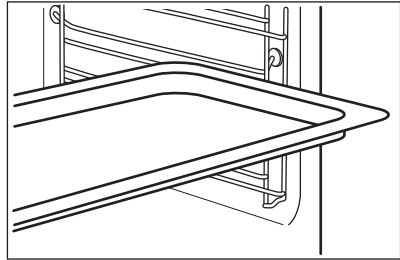
**Kombirost, Backblech /Auflaufpfanne:**

Schieben Sie das Backblech zwischen die Führungsstäbe der Einhängegitter und dem Kombirost auf die Führungsstäbe darüber.

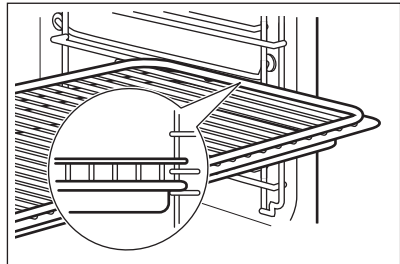

9. ZUSATZFUNKTIONEN

9.1 Kühlgebläse

Wenn der Backofen in Betrieb ist, wird das Kühlgebläse automatisch eingeschaltet, um die Ofenoberflächen zu kühlen. Wenn Sie

den Backofen ausschalten kann das Kühlgebläse weiter laufen, bis der Ofen abgekühlt ist.

10. TIPPS UND HINWEISE



Siehe Kapitel
Sicherheitshinweise.

10.1 Garempfehlungen



Die Temperaturen und Garzeiten in den Tabellen sind nur Richtwerte. Sie sind abhängig von den Rezepten, der Qualität und der Menge der verwendeten Zutaten. Ihr Backofen backt oder brät unter Umständen anders als Ihr früherer Backofen. Die Tabellen unten enthalten die empfohlenen Einstellungen für Temperatur, Gardauer und Einschubebene für die einzelnen Speisen. Finden Sie für ein bestimmtes Rezept keine konkreten Angaben, orientieren Sie sich an einem ähnlichem Rezept.

10.2 Innenseite der Tür

An der Innenseite der Tür befindet sich Folgendes:

- Die Nummern der Einschubebenen,
- Informationen über Ofenfunktionen, empfohlene Einschubebenen und Temperaturen für die Gerichte.

10.3 Backen

Nutzen Sie, wenn Sie zum ersten Mal backen, die niedrigere Temperatur.

Sie können die Backzeit um 10 - 15 Minuten verlängern, wenn Kuchen auf mehreren Ebenen gebacken werden.





Höhenunterschiede bei Kuchen und Gebäck können zu unterschiedlicher Bräunung führen. Im Fall einer unterschiedlichen Bräunung ist es nicht notwendig die Temperatur zu ändern. Die Unterschiede gleichen sich während des Backens aus.

Die Backbleche im Ofen können sich beim Backen verformen. Nachdem die Backbleche abgekühlt sind, hebt sich die Verformung wieder auf.

10.4 Backtipps

Backergebnis	Mögliche Ursache	Abhilfe
Die Unterseite des Kuchens ist nicht ausreichend gebacken.	Die Einschubebene ist nicht richtig.	Stellen Sie den Kuchen auf eine tiefere Einschubebene.
Der Kuchen fällt zusammen und ist noch teigig oder mit Wasserstreifen durchzogen.	Die Backofentemperatur ist zu hoch.	Stellen Sie beim nächsten Mal eine niedrigere Backofentemperatur ein.
	Die Backofentemperatur ist zu hoch und die Backzeit zu kurz.	Stellen Sie beim nächsten Mal eine längere Backzeit und eine niedrigere Backofentemperatur ein.
Der Kuchen ist zu trocken.	Die Backofentemperatur ist zu niedrig.	Stellen Sie beim nächsten Mal eine höhere Backofentemperatur ein.
	Die Backzeit ist zu lang.	Stellen Sie beim nächsten Mal eine kürzere Backzeit ein.
Der Kuchen ist unregelmäßig gebräunt.	Die Backofentemperatur ist zu hoch und die Backzeit zu kurz.	Stellen Sie beim nächsten Mal eine längere Backzeit und eine niedrigere Backofentemperatur ein.
	Der Kuchenteig ist nicht gleichmäßig verteilt.	Verteilen Sie beim nächsten Mal den Kuchenteig gleichmäßiger auf dem Backblech.
Der Kuchen ist nach der im Rezept angegebenen Backzeit nicht fertig gebacken.	Die Backofentemperatur ist zu niedrig.	Stellen Sie beim nächsten Mal eine etwas höhere Backofentemperatur ein.



10.5 Backen auf einer Einschubebene

 BA-CKEN IN FORMEN		 (°C)	 (Min.)	
Torteboden aus Mürbeteig, Heizen Sie den leeren Backofen vor	Heißluft	170 - 180	10 - 25	2
Torteboden aus Rührteig	Heißluft	150 - 170	20 - 25	2
Gugelhupf / Bri- oche	Heißluft	150 - 160	50 - 70	1
Sandkuchen / Früchtekuchen	Heißluft	140 - 160	70 - 90	1
Käsekuchen	Ober-/Unterhitze	170 - 190	60 - 90	1

Nutzen Sie die dritte Einschubebene.

Verwenden Sie die Funktion Heißluft.





Verwenden Sie ein Backblech.





 KUCHEN/GEBÄCK/BROTE	 (°C)	 (Min.)
Streuselkuchen	150 - 160	20 - 40
Obstkuchen (mit Hefeteig/Rührteig), verwenden Sie ein tiefes Blech	150	35 - 55
Obstkuchen mit Mürbeteig	160 - 170	40 - 80

Leeren Backofen vorheizen.





Verwenden Sie die Funktion Ober-/Unterhitze.

Verwenden Sie ein Backblech.

 KUCHEN/ GEBÄCK/BROTE	 (°C)	 (Min.)	
Biskuitrolle	180 - 200	10 - 20	3
Roggenbrot:	erst: 230	20	1
	anschließend: 160 - 180	30 - 60	
Mandelkuchen mit Butter / Zuckerkuchen	190 - 210	20 - 30	3
Windbeutel / Eclairs	190 - 210	20 - 35	3
Hefezopf / Hefekranz	170 - 190	30 - 40	3





 KUCHEN/ GEBÄCK/BROTE	 (°C)	 (Min.)	
Obstkuchen (mit Hefeteig/ Rührteig), verwenden Sie ein tiefes Blech	170	35 - 55	3
Hefekuchen mit empfindli- chen Belägen (z.B. Quark, Sahne, Pudding)	160 - 180	40 - 80	3
Christstollen	160 - 180	50 - 70	2

Nutzen Sie die dritte Einschubebene.

 KLEINGEBÄCK		 (°C)	 (Min.)
Mürbeteig-Plätzchen	Heißluft	150 - 160	10 - 20
Brötchen, Heizen Sie den lee- ren Backofen vor	Heißluft	160	10 - 25
Rührteigplätzchen	Heißluft	150 - 160	15 - 20
Blätterteiggebäck, Heizen Sie den leeren Backofen vor	Heißluft	170 - 180	20 - 30
Hefekleingebäck	Heißluft	150 - 160	20 - 40
Makronen	Heißluft	100 - 120	30 - 50
Gebäck aus Eiweiß / Baiser	Heißluft	80 - 100	120 - 150
Brötchen, Heizen Sie den lee- ren Backofen vor	Ober-/Unterhitze	190 - 210	10 - 25

10.6 Aufläufe und Gratins





Nutzen Sie die erste Einschubebene.





		 (°C)	 (Min.)
Überbackene Baguettes	Heißluft	160 - 170	15 - 30
Gemüsegratin, Heizen Sie den leeren Backofen vor	Heißluftgrillen	160 - 170	15 - 30
Lasagne	Ober-/Unterhitze	180 - 200	25 - 40
Fischaufläufe	Ober-/Unterhitze	180 - 200	30 - 60
Gefülltes Gemüse	Heißluft	160 - 170	30 - 60
Süße Aufläufe	Ober-/Unterhitze	180 - 200	40 - 60
Nudelaufwurf	Ober-/Unterhitze	180 - 200	45 - 60

10.7 Backen auf mehreren Ebenen

Benutzen Sie die Backbleche.

Verwenden Sie die Funktion Heißluft.

 KUCHEN/ GEBÄCK	 (°C)	 (Min.)	 2 Ebenen
Windbeutel / Eclairs, Heizen Sie den leeren Backofen vor	160 - 180	25 - 45	1 / 4
Streuselkuchen, trocken	150 - 160	30 - 45	1 / 4

 KLEIN- GEBÄCK/KLEI- NE KUCHEN/ GEBÄCK/BRÖT- CHEN	 (°C)	 (Min.)	 2 Ebenen	 3 Ebenen
Brötchen	180	20 - 30	1 / 4	-
Mürbeteig-Plätzchen	150 - 160	20 - 40	1 / 4	1 / 3 / 5
Rührteigplätzchen	160 - 170	25 - 40	1 / 4	-
Blätterteiggebäck, Heizen Sie den leeren Backofen vor	170 - 180	30 - 50	1 / 4	-
Hefekleingebäck	160 - 170	30 - 60	1 / 4	-
Makronen	100 - 120	40 - 80	1 / 4	-
Gebäck aus Eiweiß / Baiser	80 - 100	130 - 170	1 / 4	-

10.8 Tipps zum Braten

Benutzen Sie hitzebeständiges Geschirr.

Braten Sie mageres Fleisch abgedeckt (Sie können Aluminiumfolie verwenden).

Braten Sie große Fleischstücke direkt im Blech oder auf dem Kombirost über dem Blech.

Geben Sie etwas Wasser ins Blech, um zu verhindern, dass das herabtropfende Fett brennt.

Drehen Sie den Braten nach 1/2 - 2/3 der Gardauer.

Braten Sie Fleisch und Fisch in großen Stücken (1 kg oder mehr).

Beträufeln Sie die Fleischstücke mit dem eigenen Saft während des Bratens.

10.9 Braten

Nutzen Sie die erste Einschubebene.



RINDFLEISCH



(°C)



(Min.)

Schmorfleisch	1 - 1,5 kg	Ober-/Unterhitze	230	120 - 150
Roastbeef/Filet, blutig, Heizen Sie den leeren Backofen vor	je cm Dicke	Heißluftgrillen	190 - 200	5 - 6
Roastbeef/Filet, rosa, Heizen Sie den leeren Backofen vor	je cm Dicke	Heißluftgrillen	180 - 190	6 - 8
Roastbeef/Filet, durch, Heizen Sie den leeren Backofen vor	je cm Dicke	Heißluftgrillen	170 - 180	8 - 10



SCHWEINEFLEISCH



Verwenden Sie die Funktion Heißluftgrillen.



(kg)



(°C)



(Min.)

Schulter / Nacken / Schinken- stück	1 - 1.5		160 - 180	90 - 120
Koteletts / Rippchen	1 - 1.5		170 - 180	60 - 90
Hackbraten	0.75 - 1		160 - 170	50 - 60
Schweinsaxe, vorgegart	0.75 - 1		150 - 170	90 - 120



KALB



Verwenden Sie die Funktion Heißluftgrillen.



(kg)



(°C)



(Min.)

Kalbsbraten	1		160 - 180	90 - 120
Kalbshaxe	1.5 - 2		160 - 180	120 - 150



LAMM



Verwenden Sie die Funktion Heißluftgrillen.



(kg)



(°C)



(Min.)

Lammkeule / Lammbraten	1 - 1.5	150 - 170	100 - 120
Lammrücken	1 - 1.5	160 - 180	40 - 60



WILD



Verwenden Sie die Funktion Ober-/Unterhitze.



(kg)



(°C)



(Min.)

Rücken / Hasenkeule, Heizen Sie den leeren Backofen vor	bis zu 1	230	30 - 40
Reh-/Hirschrücken	1.5 - 2	210 - 220	35 - 40
Reh-/Hirschkeule	1.5 - 2	180 - 200	60 - 90



GEFLÜGEL



Verwenden Sie die Funktion Heißluftgrillen.



(kg)



(°C)



(Min.)

Geflügelteile	je 0,2 - 0,25	200 - 220	30 - 50
Hähnchen, halbiert	je 0,4 - 0,5	190 - 210	35 - 50
Hähnchen, Poularde	1 - 1.5	190 - 210	50 - 70
Ente	1.5 - 2	180 - 200	80 - 100
Gans	3.5 - 5	160 - 180	120 - 180
Pute	2.5 - 3.5	160 - 180	120 - 150
Pute	4 - 6	140 - 160	150 - 240



FISCH, GEDÄMPFT



Verwenden Sie die Funktion Ober-/Unterhitze.



(kg)



(°C)



(Min.)

Fisch

1 - 1.5

210 - 220

40 - 60

10.10 Knusprige Backwaren mit Pizzastufe



PIZZA



Nutzen Sie die erste Einschubebene.



(°C)



(Min.)

Obststörtchen 180 - 200 40 - 55

Spinatquiche 160 - 180 45 - 60

Quiche Lorraine / Schweizer Flan 170 - 190 45 - 55

Käsekuchen 140 - 160 60 - 90

Gemüsekuchen 160 - 180 50 - 60



PIZZA



Heizen Sie den leeren Backofen vor dem Garen vor.



Nutzen Sie die zweite Einschubebene.



(°C)



(Min.)

Pizza, dünner Boden, verwenden Sie ein tiefes Blech 200 - 230 15 - 20

Pizza, dicker Boden 180 - 200 20 - 30

Fladenbrot 230 - 250 10 - 20

Blätterteigquiche 160 - 180 45 - 55

Flammkuchen 230 - 250 12 - 20

Piroggen 180 - 200 15 - 25

10.11 Grill

Heizen Sie den leeren Backofen vor dem Garen vor.

Grillen Sie nur dünne Fleisch- oder Fischstücke.

Setzen Sie ein Kuchenblech in die erste Einschubebene, um das Fett aufzufangen.



GRILL



Verwenden Sie die Funktion: Grill



(°C)



(Min.)

Erste Seite



(Min.)

Zweite Seite



	(°C)	(Min.) Erste Seite	(Min.) Zweite Seite	
Roastbeef	210 - 230	30 - 40	30 - 40	2
Rinderfilet	230	20 - 30	20 - 30	3
Schweinelende	210 - 230	30 - 40	30 - 40	2
Kalbsrücken	210 - 230	30 - 40	30 - 40	2
Lammrücken	210 - 230	25 - 35	20 - 25	3
Fisch 0,5 kg - 1 kg	210 - 230	15 - 30	15 - 30	3 / 4

10.12 Tiefkühlgerichte



AUFTAUEN



Verwenden Sie die Funktion: Heißluft.



(°C)



(Min.)



	(°C)	(Min.)	
Pizza, gefroren	200 - 220	15 - 25	2
Pizza American, gefroren	190 - 210	20 - 25	2
Pizza, gekühlt	210 - 230	13 - 25	2
Pizzasnacks, gefroren	180 - 200	15 - 30	2
Pommes frites, dünn	200 - 220	20 - 30	3
Pommes frites, dick	200 - 220	25 - 35	3
Kartoffelspalten / Kroketten	220 - 230	20 - 35	3
Röstis	210 - 230	20 - 30	3
Lasagne / Cannelloni, frisch	170 - 190	35 - 45	2
Lasagne / Cannelloni, gefroren	160 - 180	40 - 60	2
Gebackener Käse	170 - 190	20 - 30	3
Hähnchenflügel	190 - 210	20 - 30	2

10.13 Auftauen





Nehmen Sie die Lebensmittel aus der Verpackung und legen Sie sie auf einen Teller.

Bedecken Sie die Speise nicht, da dies die Auftauzeit verlängern kann.

Legen Sie bei größeren Nahrungsmittelportionen einen leeren

Nutzen Sie die erste Einschubebene.

umgedrehten Teller auf den Garraumboden. Legen Sie die Speise in eine tiefe Schüssel und stellen Sie sie auf den Teller im Backofen. Entfernen Sie bei Bedarf die Einhängegitter.

	 (kg)	 (Min.) Auftauzeit	 (Min.) Zusätzliche Auftauzeit	
Hähnchen	1	100 – 140	20 – 30	Nach der Hälfte der Gardauer wenden.
Fleisch	1	100 – 140	20 – 30	Nach der Hälfte der Gardauer wenden.
Forelle	0,15	25 – 35	10 – 15	–
Erdbeeren	0,3	30 – 40	10 – 20	–
Butter	0,25	30 – 40	10 – 15	–
Sahne	2 x 0,2	80 – 100	10 – 15	Sahne im leicht gefrorenen Zustand aufschlagen.
Torte	1,4	60	60	–

10.14 Einkochen

Verwenden Sie die Funktion Unterhitze.

Verwenden Sie nur handelsübliche Einmachgläser mit denselben Abmessungen.

Verwenden Sie keine Einmachgläser mit Schraub- und Bajonettdeckeln oder Metall Dosen.

Nutzen Sie die erste Einschubebene.

Stellen Sie nicht mehr als sechs Ein-Liter-Einmachgläser auf das Backblech.



Füllen Sie die Einmachgläser gleichmäßig und verschließen Sie sie mit einer Klammer.



Die Einmachgläser dürfen sich nicht berühren.



Geben Sie ungefähr 0,5 l Wasser ins Backblech, um ausreichend Feuchtigkeit im Backofen sicherzustellen.

Wenn die Flüssigkeit in den Einmachgläsern zu köcheln beginnt (nach ungefähr 35-60 Minuten bei 1-l-Einmachgläsern), schalten Sie den Backofen aus oder reduzieren Sie die Temperatur auf 100 °C (siehe Tabelle).

Stellen Sie die Temperatur auf 160 - 170 °C ein.

 BEERENOBST	 (Min.) Gardauer bis zum Köcheln
Erdbeeren / Blaubeeren / Himbeeren / Reife Stachelbeeren	35 - 45

 STEIN-OBST	 (Min.) Gardauer bis zum Köcheln	 (Min.) Kochen Sie weiter bei 100 °C
Pfirsiche / Quit-ten / Pflaumen	35 - 45	10 - 15

 GE-MÜSE	 (Min.) Gardauer bis zum Köcheln	 (Min.) Kochen Sie weiter bei 100 °C
Karotten	50 - 60	5 - 10
Gurken	50 - 60	-
Mixed Pickles	50 - 60	5 - 10
Kohlrabi / Erb- sen / Spargel	50 - 60	15 - 20

10.15 Dörren - Heißluft



Verwenden Sie mit Butterbrot- oder Backpapier belegte Bleche.

Sie erzielen ein besseres Ergebnis, wenn Sie nach halber Dörzeit den Backofen



ausschalten, öffnen und am besten über Nacht auskühlen lassen.

Nutzen Sie für 1 Blech die dritte Einschubebene.

Für 2 Bleche verwenden Sie die erste und vierte Einschubebene.

 GEMÜSE	 (°C)	 (Std.)
Bohnen	60 - 70	6 - 8
Paprika	60 - 70	5 - 6
Suppengemüse	60 - 70	5 - 6
Pilze	50 - 60	6 - 8
Kräuter	40 - 50	2 - 3

Stellen Sie die Temperatur auf 60 - 70 °C ein.

 OBST	 (Std.)
Pflaumen	8 - 10
Aprikosen	8 - 10
Apfelscheiben	6 - 8
Birnen	6 - 9

10.16 Feuchte Umluft - Empfohlenes Zubehör

Verwenden Sie die dunklen und nicht reflektierenden Formen und Behälter. Sie haben eine bessere Wärmeabsorption als helle Farbe und reflektierende Schüsseln.



Pizzapfanne

Dunkel, nicht reflektierend
28 cm Durchmesser



Backform

Dunkel, nicht reflektierend
26 cm Durchmesser



Förmchen

Keramikform
8 cm Durchmes-
ser, 5 cm Höhe







Tortenbodenform

Dunkel, nicht reflektierend
28 cm Durchmesser







10.17 Feuchte Umluft







Beachten Sie für beste Ergebnisse die unten in der Tabelle aufgeführten Empfehlungen.

	 (°C)	 (Min.)	
Grissini, 0,5 kg insgesamt	190 - 200	50 - 60	3
Jakobsmuscheln in der Schale gebacken	180 - 200	30 - 40	4
Fisch in Salzkruste, 0,3 - 0,5 kg	190 - 200	45 - 50	4
Fisch in Pergamentpapier, 0,3 - 0,5 kg	190 - 200	50 - 60	3
Amaretti (20; 0,5 kg insgesamt)	170 - 180	40 - 50	3
Apfelstreusel	190 - 200	50 - 60	4
Schokoladen-Muffins (20; 0,5 kg insgesamt)	160 - 170	35 - 45	3

10.18 Informationen für Prüfinstitute

Tests gemäß EN 60350, IEC 60350.

 BACKEN AUF EINER EINSCHUBELENE. Backen in Formen				
		 (°C)	 (Min.)	
Biskuit (fettfrei)	Heißluft	140 - 150	35 - 50	2
Biskuit (fettfrei)	Ober-/Unterhitze	160	35 - 50	2
Apfelkuchen, 2 Formen à Ø 20 cm	Heißluft	160	60 - 90	2
Apfelkuchen, 2 Formen à Ø 20 cm	Ober-/Unterhitze	180	70 - 90	1

 BACKEN AUF EINER EINSCHUBELENE. Plätzchen				
 Nutzen Sie die dritte Einschubebene.				
		 (°C)	 (Min.)	
Mürbeteiggebäck / Feingebäck	Heißluft	140	25 - 40	
Mürbeteiggebäck / Feingebäck, Heizen Sie den leeren Backofen vor	Ober-/Unterhitze	160	20 - 30	



BACKEN AUF EINER EINSCHUBELENE. Plätzchen



Nutzen Sie die dritte Einschubebene.



(°C)



(Min.)

Törtchen, 20 pro Blech, Heizen
Sie den leeren Backofen vor

Heißluft

150

20 - 35

Törtchen, 20 pro Blech, Heizen
Sie den leeren Backofen vor

Ober-/Unterhitze

170

20 - 30



BACKEN AUF MEHREREN EBENEN. Plätzchen



(°C)



(Min.)



Mürbeteiggebäck / Feingebäck

Heißluft

140

25 - 45

1 / 4

Törtchen, 20 pro Blech, Heizen
Sie den leeren Backofen vor

Heißluft

150

23 - 40

1 / 4

Biskuit (fettfrei)

Heißluft

160

35 - 50

1 / 4



GRILL



Heizen Sie den leeren Backofen 5 Min. vor.



Grillen Sie bei maximaler Temperatureinstellung.



(Min.)



Toast

Grill

1 - 3

5

Rindersteak, Nach der Hälfte der
Zeit wenden

Grill

24 - 30

4

11. REINIGUNG UND PFLEGE



WARNUNG!

Siehe Kapitel
Sicherheitshinweise.

11.1 Hinweise zur Reinigung



Reinigungsmittel

Feuchten Sie ein weiches Tuch mit warmem Wasser und etwas mildem Reinigungsmittel an, und reinigen Sie damit die Vorderseite des Backofens.

Reinigen Sie die Metalloberflächen mit einer Reinigungslösung.

Reinigen Sie Flecken mit einem milden Reinigungsmittel.



Täglicher Gebrauch

Reinigen Sie den Garraum nach jedem Gebrauch. Fettansammlungen oder andere Speisereste könnten einen Brand verursachen.

Lassen Sie die Speisen nicht länger als 20 Minuten im Backofen stehen. Trocknen Sie den Garraum nach jedem Gebrauch mit einem weichen Tuch ab.



Zubehör

Reinigen Sie alle Zubehörteile nach jedem Gebrauch und lassen Sie sie trocknen. Feuchten Sie ein weiches Tuch mit warmem Wasser und einem milden Reinigungsmittel an. Reinigen Sie die Zubehörteile nicht im Geschirrspüler.

Reinigen Sie das Zubehör mit Antihafbeschichtung nicht mit Scheuermitteln oder scharfkantigen Gegenständen.

11.2 Entfernen: Einhängegitter

Entfernen Sie Einhängegitter zur Reinigung des Backofens.

Schritt 1 Schalten Sie den Backofen aus und warten Sie, bis er abgekühlt ist.

Schritt 2 Ziehen Sie das Einhängegitter vorne von der Seitenwand weg.

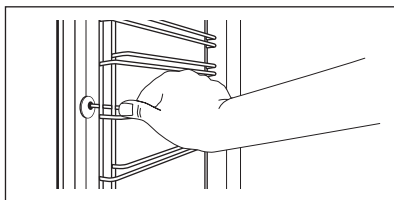

Schritt 3 Ziehen Sie das Einhängegitter hinten von der Seitenwand weg und nehmen Sie es heraus.

Schritt 4 Führen Sie zum Einsetzen der Einhängegitter die oben aufgeführten Schritte in umgekehrter Reihenfolge durch.

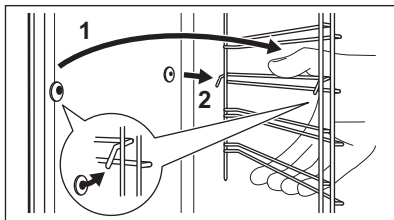

11.3 Entfernen: Grill



WARNUNG!

Es besteht Verbrennungsgefahr.

Schritt 1 Schalten Sie den Backofen aus und warten Sie, bis er abgekühlt ist, um ihn zu reinigen.
Entfernen Sie die Einhängegitter.

Schritt 2 Fassen Sie die Ecken des Grills. Ziehen Sie ihn gegen die Federkraft nach vorne und aus beiden Halterungen heraus. Der Grill klappt nach unten.

Schritt 3 Reinigen Sie die Backofendecke mit warmem Wasser, einem weichen Tuch und einem milden Reinigungsmittel. Lassen Sie sie trocknen.

Schritt 4 Führen Sie zum Einsetzen des Grillelements die oben beschriebenen Schritte in umgekehrter Reihenfolge durch.

Schritt 5 Setzen Sie die Einhängegitter wieder ein.

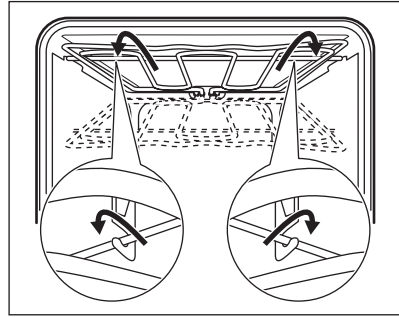

11.4 Aus- und Einbau der:

Die Anzahl der Glasscheiben variiert je nach Modell.



VORSICHT!

Behandeln Sie das Glas vorsichtig, insbesondere an den Kanten der vorderen Scheibe. Das Glas kann zerbrechen.

11.5 Austausch: Lampe



WARNUNG!

Stromschlaggefahr.
Die Lampe kann heiß sein.

Bevor Sie die Lampe austauschen:

Schritt 1	Schritt 2	Schritt 3
Schalten Sie den Backofen aus. Warten Sie, bis der Ofen kalt ist.	Trennen Sie den Ofen von der Netzversorgung.	Breiten Sie ein Tuch auf dem Garraumboden aus.

Obere Lampe

Schritt 1 Drehen Sie die Glasabdeckung und nehmen Sie sie ab.

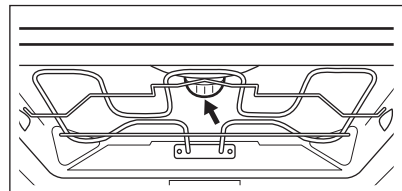

Schritt 2 Reinigen Sie die Glasabdeckung.

Schritt 3 Ersetzen Sie die Lampe durch eine geeignete, bis 300 °C hitzebeständige Lampe.

Schritt 4 Bringen Sie die Glasabdeckung wieder an.

12. FEHLERSUCHE



WARNUNG!
Siehe Kapitel
Sicherheitshinweise.

12.1 Was tun, wenn...

In allen Fällen, die nicht in dieser Tabelle aufgeführt sind, wenden Sie sich bitte an einen autorisierten Kundendienst.

Störung	Prüfen Sie, ob...
Der Backofen nicht heizt.	Die Sicherung durchgebrannt ist.
Das Display „12.00“ anzeigt.	Es einen Stromausfall gab. Stellen Sie die Uhrzeit ein.

Störung	Prüfen Sie, ob...
Die Lampe nicht funktioniert.	Die Lampe durchgebrannt ist.

12.2 Servicedaten

Wenn Sie das Problem nicht selbst lösen können, wenden Sie sich an Ihren Händler oder einen autorisierten Kundendienst.

Die vom Kundendienst benötigten Daten finden Sie auf dem Typenschild. Das Typenschild befindet sich am Frontrahmen des Garraums. Entfernen Sie das Typenschild nicht vom Garraum.

Wir empfehlen, hier folgende Daten zu notieren:

Modell (MOD.)
Produktnummer (PNC)
Seriennummer (S.N.)

13. ENERGIEEFFIZIENZ

13.1 Produktinformationen und Produktdatenblatt*

Herstellername	AEG
Modellidentifikation	BEK435220M 944188023
Energieeffizienzindex	81.2
Energieeffizienzklasse	A+
Energieverbrauch bei Standardbelastung, Ober-/Unterhitze	0.99 kWh/Programm
Energieverbrauch bei Standardbelastung, Umluft	0.69 kWh/Programm
Anzahl der Garräume	1
Wärmequelle	Strom
Fassungsvermögen	71 l
Backofentyp	Einbau-Backofen
Gewicht	34.0 kg

* Für die Europäische Union gemäß EU-Richtlinien 65/2014 und 66/2014.
Für die Republik Weißrussland gemäß STB 2478-2017, Anhang G; STB 2477-2017, Anlagen A und B.
Für die Ukraine gemäß 568/32020.

Die Energieeffizienzklasse gilt nicht für Russland.

EN 60350-1 - Elektrische Kochgeräte für den Hausgebrauch - Teil 1: Herde, Backöfen, Dampfgarer und Grillgeräte - Verfahren zur Messung der Gebrauchseigenschaften.

13.2 Energie sparen



Der Backofen verfügt über Funktionen, mit deren Hilfe Sie beim täglichen Kochen Energie sparen können.

Achten Sie darauf, dass die Backofentür während des Ofenbetriebs geschlossen ist. Die Backofentür darf während des Garvorgangs nicht zu oft geöffnet werden. Halten Sie die Türdichtung sauber und stellen Sie sicher, dass sie sich fest in der richtigen Position befindet.

Verwenden Sie Kochgeschirr aus Metall, um mehr Energie zu sparen.

Heizen Sie, wenn möglich, den Backofen nicht vor.

Halten Sie die Unterbrechungen beim Backen so kurz wie möglich, wenn Sie mehrere Speisen gleichzeitig zubereiten.

Garen mit Heißluft

Nutzen Sie, wenn möglich, die Garfunktionen mit Heißluft, um Energie zu sparen.

Restwärme

Beträgt die Garzeit mehr als 30 Minuten, reduzieren Sie die Ofentemperatur 3 - 10 Min. vor Ablauf des Garvorgangs. Durch die Restwärme des Backofens werden die Speisen weiter gegart.

Nutzen Sie die Restwärme, um andere Speisen aufzuwärmen.

Warmhalten von Speisen

Wählen Sie die niedrigste Temperatureinstellung, wenn Sie die Restwärme zum Warmhalten von Speisen nutzen möchten.

Feuchte Umluft

Diese Funktion ist entwickelt worden, um während des Garvorgangs Energie zu sparen.

14. UMWELTTIPPS

Recyceln Sie Materialien mit dem Symbol . Entsorgen Sie die Verpackung in den entsprechenden Recyclingbehältern. Recyceln Sie zum Umwelt- und Gesundheitsschutz elektrische und elektronische Geräte. Entsorgen Sie Geräte

mit diesem Symbol  nicht mit dem Hausmüll. Bringen Sie das Gerät zu Ihrer örtlichen Sammelstelle oder wenden Sie sich an Ihr Gemeindeamt.

PER RISULTATI PERFETTI

Grazie per aver scelto di acquistare questo prodotto AEG. Lo abbiamo creato per fornirvi prestazioni impeccabili per molti anni, grazie a tecnologie innovative che vi semplificheranno la vita - funzioni che non troverete sulle normali apparecchiature. Vi invitiamo di dedicare qualche minuto alla lettura per sapere come trarre il massimo dal vostro elettrodomestico.

Visitate il nostro sito web per:



Ricevere consigli, scaricare i nostri opuscoli, eliminare eventuali anomalie, ottenere informazioni sull'assistenza e la riparazione:

www.aeg.com/support



Per registrare il vostro prodotto e ricevere un servizio migliore:

www.registeraeg.com



Acquistare accessori, materiali di consumo e ricambi originali per la vostra apparecchiatura:

www.aeg.com/shop

SERVIZIO CLIENTI E MANUTENZIONE

Consigliamo sempre l'impiego di ricambi originali.

Quando si contatta l'Assistenza, accertarsi di disporre dei seguenti dati: Modello, PNC, numero di serie.

Le informazioni si trovano sulla targhetta dei dati.

 **Avvertenza / Attenzione - Importanti Informazioni di Sicurezza.**

 **Informazioni e consigli generali**

 **Informazioni ambientali**

Con riserva di modifiche.

INDICE

1. INFORMAZIONI DI SICUREZZA.....	83
2. ISTRUZIONI DI SICUREZZA.....	85
3. DESCRIZIONE DEL PRODOTTO.....	88
4. PANNELLO DEI COMANDI.....	89
5. PRIMA DI UTILIZZARE L'ELETTRODOMESTICO.....	89
6. UTILIZZO QUOTIDIANO.....	90
7. FUNZIONI DEL TIMER.....	91
8. UTILIZZO DEGLI ACCESSORI.....	92
9. FUNZIONI AGGIUNTIVE.....	93
10. CONSIGLI E SUGGERIMENTI UTILI.....	93
11. PULIZIA E CURA.....	106
12. RISOLUZIONE DEI PROBLEMI.....	109
13. EFFICIENZA ENERGETICA.....	109

1. INFORMAZIONI DI SICUREZZA

Leggere attentamente le istruzioni fornite prima di installare e utilizzare l'apparecchiatura. I produttori non sono responsabili

di eventuali lesioni o danni derivanti da un'installazione o un uso scorretti. Conservare sempre le istruzioni in un luogo sicuro e accessibile per poterle consultare in futuro.

1.1 Sicurezza di bambini e persone vulnerabili

- Questa apparecchiatura può essere usata da bambini a partire dagli 8 anni e da adulti con limitate capacità fisiche, sensoriali o mentali o con scarsa esperienza o conoscenza sull'uso dell'apparecchiatura, solamente se sorvegliati o se istruiti relativamente all'uso dell'apparecchiatura e se hanno compreso i rischi coinvolti. I bambini che hanno meno di 8 anni e le persone con disabilità diffuse e complesse vanno tenuti lontani dall'apparecchiatura a meno che non vi sia una supervisione continua.
- Non lasciare che i bambini giochino con l'apparecchiatura.
- Tenere gli imballaggi lontano dai bambini e smaltirli in modo adeguato.
- **AVVERTENZA:** Tenere i bambini e gli animali domestici lontano dall'apparecchiatura durante il funzionamento o raffreddamento. Alcune parti accessibili diventano calde durante l'uso.
- Se l'apparecchiatura ha un dispositivo di sicurezza per i bambini sarà opportuno attivarlo.
- I bambini non devono eseguire interventi di pulizia e manutenzione sull'apparecchiatura senza essere supervisionati.

1.2 Avvertenze di sicurezza generali

- L'installazione dell'apparecchiatura e la sostituzione dei cavi deve essere svolta unicamente da personale qualificato.
- **AVVERTENZA:** L'apparecchiatura e le parti accessibili si riscaldano molto durante l'uso. Abbiate cura di non toccare gli elementi riscaldanti.
- Servirsi sempre degli appositi guanti da forno per estrarre o inserire accessori o pentole resistenti al calore.
- Prima di qualsiasi intervento di manutenzione, scollegare l'apparecchiatura dalla presa di corrente.

- **AVVERTENZA:** Assicurarsi che l'apparecchiatura sia spenta prima di sostituire la lampadina per evitare la possibilità di scosse elettriche.
- Non usare l'apparecchiatura prima di installarla nella struttura a incasso.
- Non usare una pulitrice a vapore per pulire l'apparecchiatura.
- Non utilizzare detergenti abrasivi o raschietti di metallo per pulire il vetro della porta per non rigare la superficie e causare la rottura del vetro.
- Se il cavo di alimentazione è danneggiato, deve essere sostituito dal produttore, da un tecnico autorizzato o da una persona qualificata per evitare situazioni di pericolo.
- Per rimuovere i supporti ripiano, sfilare innanzitutto la parte anteriore del supporto, quindi quella posteriore, dalle pareti laterali. Installare i supporti griglia seguendo al contrario la procedura indicata.

2. ISTRUZIONI DI SICUREZZA

2.1 Installazione



AVVERTENZA!

L'installazione dell'apparecchiatura deve essere eseguita da personale qualificato.

- Rimuovere tutti i materiali di imballaggio.
- Non installare o utilizzare l'apparecchiatura se è danneggiata.
- Attenersi alle istruzioni fornite insieme all'apparecchiatura.
- Prestare sempre attenzione in fase di spostamento dell'apparecchiatura, dato che è pesante. Usare sempre i guanti di sicurezza e le calzature adeguate.
- Non tirare l'apparecchiatura per la maniglia.
- Installare l'apparecchiatura in un luogo sicuro e idoneo che soddisfi i requisiti di installazione.
- È necessario rispettare la distanza minima dalle altre apparecchiature.

- Prima di montare l'apparecchiatura controllare che la porta del forno si apra senza limitazioni.
- L'apparecchiatura è dotata di un sistema elettrico di raffreddamento. Questo deve essere alimentato elettricamente.
- La stabilità del mobile da incasso deve essere conforme alla norma DIN 68930.

Altezza minima del mobiletto (mobiletto sotto all'altezza minima del piano di lavoro)	578 (600) mm
---------------------------------------------------------------------------------------	--------------

Larghezza del mobiletto	560 mm
-------------------------	--------

Profondità del mobiletto	550 (550) mm
--------------------------	--------------

Altezza della parte anteriore dell'apparecchiatura	594 mm
----------------------------------------------------	--------

Altezza della parte posteriore dell'apparecchiatura	576 mm
-----------------------------------------------------	--------

Larghezza della parte anteriore dell'apparecchiatura	595 mm
------------------------------------------------------	--------

Larghezza della parte posteriore dell'apparecchiatura	559 mm
Profondità dell'apparecchiatura	567 mm
Profondità di incasso dell'apparecchiatura	546 mm
Profondità con obliò aperto	1027 mm
Dimensioni minime dell'apertura di ventilazione. Apertura collocata sul lato posteriore inferiore	560 x 20 mm
Lunghezza del cavo di alimentazione. Il cavo è collocato nell'angolo destro del lato posteriore.	1500 mm
Viti di montaggio	4 x 25 mm

2.2 Collegamento elettrico



AVVERTENZA!

Rischio di incendio e scossa elettrica.

- Tutti i collegamenti elettrici devono essere realizzati da un elettricista qualificato.
- L'apparecchiatura deve disporre di una messa a terra.
- Verificare che i parametri sulla targhetta siano compatibili con le indicazioni elettriche dell'alimentazione.
- Utilizzare sempre una presa elettrica con contatto di protezione correttamente installata.
- Non utilizzare prese multiple e prolunghe.
- Accertarsi di non danneggiare la spina e il cavo. Qualora il cavo elettrico debba essere sostituito, l'intervento dovrà essere effettuato dal nostro Centro di Assistenza autorizzato.
- Evitare che i cavi entrino a contatto o si trovino vicino alla porta dell'apparecchiatura o sulla nicchia sotto all'apparecchiatura, in particolare quando il dispositivo è in funzione o la porta è calda.
- I dispositivi di protezione da scosse elettriche devono essere fissati in modo tale da non poter essere disattivati senza l'uso di attrezzi.
- Inserire la spina di alimentazione nella presa solo al termine dell'installazione.

Verificare che la spina di alimentazione rimanga accessibile dopo l'installazione.

- Nel caso in cui la spina di corrente sia allentata, non collegarla alla presa.
- Non tirare il cavo di alimentazione per scollegare l'apparecchiatura. Tirare sempre dalla spina.
- Servirsi unicamente di dispositivi di isolamento adeguati: interruttori automatici, fusibili (quelli a tappo devono essere rimossi dal portafusibile), sganciatori per correnti di guasto a terra e relè.
- L'impianto elettrico deve essere dotato di un dispositivo di isolamento che consenta di scollegare l'apparecchiatura dalla presa di corrente a tutti i poli. Il dispositivo di isolamento deve avere una larghezza dell'apertura di contatto non inferiore ai 3 mm.
- La dotazione standard dell'apparecchiatura al momento della fornitura prevede una spina e un cavo di rete.

2.3 Utilizzo



AVVERTENZA!

Rischio di lesioni, ustioni, scosse elettriche o esplosioni.

- Questa apparecchiatura è stata prevista unicamente per un uso domestico.
- Non modificare le specifiche tecniche dell'apparecchiatura.
- Accertarsi che le fessure di ventilazione non siano ostruite.
- Non lasciare mai l'apparecchiatura incustodita durante il funzionamento.
- Spegnerne l'apparecchiatura dopo ogni utilizzo.
- Prestare attenzione in fase di apertura della porta dell'apparecchiatura quando quest'ultima è in funzione. Può fuoriuscire aria calda.
- Non mettere in funzione l'apparecchiatura con le mani umide o quando c'è un contatto con l'acqua.
- Non esercitare pressione sulla porta aperta.
- Non utilizzare l'apparecchiatura come superficie di lavoro o come piano di appoggio.
- Aprire la porta dell'apparecchiatura con cautela. L'uso di ingredienti contenenti

alcol può causare una miscela di alcol e aria.

- Evitare la presenza di scintille o fiamme aperte vicino all'apparecchiatura quando si apre la porta.
- Non appoggiare o tenere liquidi o materiali infiammabili, né oggetti facilmente incendiabili sull'apparecchiatura, al suo interno o nelle immediate vicinanze.



AVVERTENZA!

Vi è il rischio di danneggiare l'apparecchiatura.

- Per evitare danni o scolorimento dello smalto:
 - Non mettere pentole resistenti al calore o altri oggetti direttamente sulla superficie inferiore dell'apparecchiatura.
 - Non appoggiare la pellicola di alluminio direttamente sulla parte bassa della cavità dell'apparecchiatura.
 - Non mettere direttamente acqua all'interno dell'apparecchiatura calda.
 - Non tenere piatti umidi e cibo all'interno dell'apparecchiatura dopo aver terminato la fase di cottura.
 - Prestare attenzione quando si tolgono o inseriscono gli accessori.
- Lo scolorimento dello smalto o dell'acciaio inox non influisce sulle prestazioni dell'apparecchiatura.
- Per le torte molto umide, usare una leccarda. I succhi di frutta provocano macchie che possono essere permanenti.
- L'apparecchiatura è destinata solo alla cottura. Non deve essere utilizzata per altri scopi, come per esempio il riscaldamento di un ambiente.
- La cottura deve sempre essere eseguita con la porta del forno chiusa.
- Se l'apparecchiatura si trova dietro a un pannello anteriore (ad es. una porta), assicurarsi che questo non sia mai chiuso quando l'apparecchiatura è in funzione. Calore e umidità possono accumularsi sul retro di un pannello chiuso causando danni all'apparecchiatura, all'alloggiamento o al pavimento. Non chiudere il pannello dell'armadio finché l'apparecchiatura non si è completamente raffreddata dopo l'uso.

2.4 Pulizia e cura



AVVERTENZA!

Vi è il rischio di lesioni, incendio o danni all'apparecchiatura.

- Prima di eseguire qualunque intervento di manutenzione, spegnere l'apparecchiatura ed estrarre la spina dalla presa.
- Controllare che l'apparecchiatura sia fredda. Vi è il rischio che i pannelli in vetro si rompano.
- Sostituire immediatamente i pannelli in vetro della porta nel caso in cui siano danneggiati. Contattare il Centro Assistenza Autorizzato.
- Pulire regolarmente l'apparecchiatura per evitare il deterioramento dei materiali che compongono la superficie.
- Pulire l'apparecchiatura con un panno inumidito e morbido. Utilizzare solo detergenti neutri. Non usare prodotti abrasivi, spugnette abrasive, solventi od oggetti metallici.
- Se si utilizza uno spray per il forno, seguire attentamente le istruzioni di sicurezza sulla confezione.

2.5 Illuminazione interna



AVVERTENZA!

Pericolo di scosse elettriche.

- Per quanto riguarda la lampada o le lampade all'interno di questo prodotto e le lampade di ricambio vendute separatamente: Queste lampade sono destinate a resistere a condizioni fisiche estreme negli elettrodomestici, come temperatura, vibrazioni, umidità, o sono destinate a segnalare informazioni sullo stato operativo dell'apparecchio. Non sono destinate ad essere utilizzate in altre applicazioni e non sono adatte per l'illuminazione di ambienti domestici.
- Servirsi unicamente di lampadine con le stesse specifiche tecniche.

2.6 Assistenza tecnica

- Per riparare l'apparecchiatura contattare un Centro di Assistenza Autorizzato.
- Utilizzare esclusivamente ricambi originali.

2.7 Smaltimento



AVVERTENZA!

Rischio di lesioni o soffocamento.

- Staccare la spina dall'alimentazione elettrica.

- Tagliare il cavo elettrico dell'apparecchiatura e smaltirlo.
- Togliere il blocco porta per evitare che bambini o animali restino intrappolati nell'apparecchiatura.

3. DESCRIZIONE DEL PRODOTTO

3.1 Panoramica

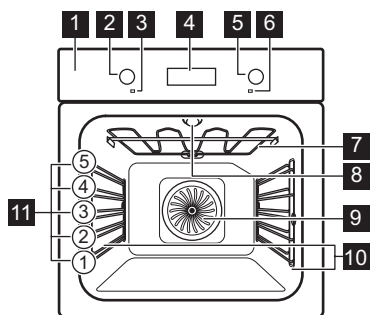

- 1 Pannello di controllo
- 2 Manopola di regolazione delle funzioni di riscaldamento
- 3 Lampadina/simbolo alimentazione
- 4 Display
- 5 Manopola di regolazione (per la temperatura)
- 6 Indicatore della temperatura / simbolo
- 7 Resistenza
- 8 Lampadina
- 9 Ventilatore
- 10 Supporto ripiano, smontabile
- 11 Posizioni dei ripiani

3.2 Accessori

Griglia

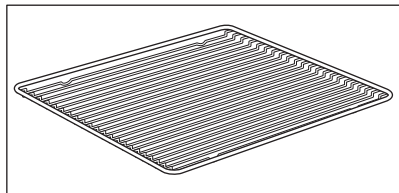

Per pentole, stampi per dolci, arrostiti.

Lamiera dolci

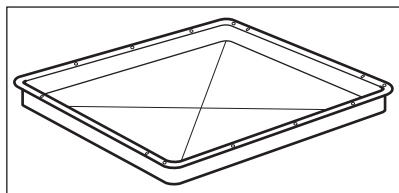

Per la cottura di torte e biscotti.

leccarda

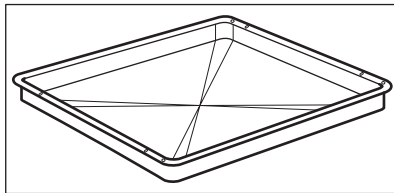

Per cuocere al forno, arrostiti o come recipiente per raccogliere i grassi.

4. PANNELLO DEI COMANDI

4.1 Manopola incassabile

Per utilizzare l'apparecchiatura, premere la manopola. La manopola fuoriesce.

4.2 Campo sensore / Pulsante

—	Per impostare l'ora.
⌚	Per impostare una funzione orologio.
+	Per impostare l'ora.

4.3 Display

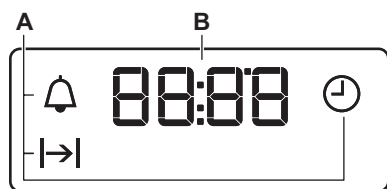

- A. Funzioni dell'orologio
- B. Timer

5. PRIMA DI UTILIZZARE L'ELETTRODOMESTICO



AVVERTENZA!

Fare riferimento ai capitoli sulla sicurezza.

5.1 Preparazione al primo utilizzo

Il forno può produrre un odore sgradevole e fumo in fase di pre-riscaldamento. Accertarsi che la stanza sia ventilata.



Fase 1

Impostare l'ora









Fase 2

Pulire il forno



Fase 3

Preriscaldare il forno vuoto

- | | | |
|----------------------------------------------------------------------------------------------------------------------------------------------------------------------------------------------------------------------------------------------------------------------------------------------------------------------------------------------------------------------------------------------------------------------------------------------------------------------------------------------------------------------------------------------------------------------------------------------------|-----------------------------------------------------------------------------------------------------------------------------------------------------------------------------------------------------------------------------------------|----------------------------------------------------------------------------------------------------------------------------------------------------------------------------------------------------------------------------------------------------------------------------------------------------------------------------------------------------------------------------|
| <ol style="list-style-type: none"> 1. Premere:  2.  - premere per impostare l'ora. Premere:  3.  - premere per impostare i minuti. Premere:  | <ol style="list-style-type: none"> 1. Togliere gli accessori e i supporti ripiano amovibili dal forno. 2. Pulire il forno e gli accessori con un panno morbido imbevuto di acqua tiepida e detergente delicato. | <ol style="list-style-type: none"> 1. Impostare la temperatura massima per la funzione: 
Tempo: 1 h. 2. Impostare la temperatura massima per la funzione: 
Tempo: 15 min |
|----------------------------------------------------------------------------------------------------------------------------------------------------------------------------------------------------------------------------------------------------------------------------------------------------------------------------------------------------------------------------------------------------------------------------------------------------------------------------------------------------------------------------------------------------------------------------------------------------|-----------------------------------------------------------------------------------------------------------------------------------------------------------------------------------------------------------------------------------------|----------------------------------------------------------------------------------------------------------------------------------------------------------------------------------------------------------------------------------------------------------------------------------------------------------------------------------------------------------------------------|

Spegner il forno e attendere che sia freddo. Collocare gli accessori e i supporti ripiano amovibili nel forno.

6. UTILIZZO QUOTIDIANO



AVVERTENZA!

Fare riferimento ai capitoli sulla sicurezza.

6.1 Come impostare: Funzione cottura

Fase 1 Ruotare la manopola delle funzioni di riscaldamento per selezionare una funzione di riscaldamento.

Fase 2 Ruotare la manopola di controllo per selezionare la temperatura.

Fase 3 Al termine della cottura, ruotare le manopole fino alla posizione off per spegnere il forno.

6.2 Funzioni cottura

Funzione cottura	Applicazione
------------------	--------------

0

Il forno è spento.

Posizione di spento



Luce forno

Per accendere la lampada.



Cottura ventilata

Per cuocere su un massimo di tre ripiani contemporaneamente e per asciugare gli alimenti. Impostare la temperatura 20 - 40 °C inferiore a per Cottura convenzionale .

Funzione cottura	Applicazione
------------------	--------------



Funzione Pizza

Per cuocere la pizza al forno. Per abbrustolire in modo intensivo ed avere un fondo croccante.



Cottura convenzionale

Per cuocere e arrostitre alimenti su una sola posizione della griglia.



Resistenza inferiore

Per cuocere torte dal fondo croccante e conservare gli alimenti.



Scongelamento

Per scongelare gli alimenti (verdure e frutta). Il tempo di sbrinamento dipende dalla quantità e dalle dimensioni degli alimenti congelati.



Cottura ventilata umida

Questa funzione è stata progettata per risparmiare energia durante la cottura. Quando si utilizza questa funzione, la temperatura nella cavità può differire dalla temperatura impostata. Viene utilizzato il calore residuo. La potenza di riscaldamento può essere ridotta. Per ulteriori informazioni, fare riferimento al capitolo "Uso quotidiano", Note su: Cottura ventilata umida.



Grill

Per grigliare pezzi sottili e tostare il pane.

Funzione cottura

Applicazione



Turbo Grill

Per tostare grandi pezzi di carne o pollame con le ossa in una posizione del ripiano. Per fare gratin e abbrustolire.



La lampada si potrebbe spegnere automaticamente a temperature inferiori a 60°C durante alcune funzioni del forno.

6.3 Note su: Cottura ventilata umida

Questa funzione è stata usata per attenersi alla classe energetica e ai requisiti di

ecodesign conformemente alla normativa EU 65/2014 e EU 66/2014. Test conformemente alla norma EN 60350-1.

La porta del forno dovrebbe essere chiusa in fase di cottura, di modo che la funzione non venga interrotta. Ciò garantisce inoltre che il forno funzioni con la più elevata efficienza energetica possibile.

Per istruzioni di cottura rimandiamo al capitolo "Consigli e suggerimenti", Cottura ventilata umida. Per indicazioni generali relativamente al risparmio energetico rimandiamo al capitolo "Efficienza energetica", Risparmio energetico.

7. FUNZIONI DEL TIMER

7.1 Funzioni dell'orologio

Funzione orologio

Applicazione



Imposta ora

Permette di modificare o controllare l'ora.



Durata

Per impostare la durata di funzionamento del forno.



Contaminuti

Per impostare il conto alla rovescia. Questa funzione non ha effetto sull'uso del forno. È possibile impostare questa funzione in qualsiasi momento, anche quando il forno è spento.

7.2 Come impostare: Funzioni dell'orologio

Come sostituire: Imposta ora

- lampeggia quando si collega il forno all'alimentazione elettrica, quando c'è stato un blackout o quando il timer non è impostato.

Fase 1 - premere ripetutamente. - inizia a lampeggiare.

Fase 2 , - premere per impostare l'ora.
Dopo 5 secondi circa, la spia smette di lampeggiare e l'orologio indica l'ora impostata.





- premere ripetutamente per cambiare l'ora del giorno. - inizia a lampeggiare.

Come impostare: Durata

Fase 1 Impostare una funzione del forno e la temperatura.

Come impostare: Durata

Fase 2  - premere ripetutamente.  - inizia a lampeggiare.



Fase 3 ,  - premere per impostare la durata.
Il display mostra: .
 - lampeggia al termine del tempo impostato. Il segnale suona e il forno si spegne.

Fase 4 Premete un tasto qualsiasi per disattivare il segnale.

Fase 5 Ruotare la manopola fino a portarla alla posizione di spegnimento.

Come impostare: Contaminuti

Fase 1  - premere ripetutamente.  - inizia a lampeggiare.

Fase 2 ,  - premere per impostare l'ora.
La funzione si avvia automaticamente dopo 5 secondi.
Quando si conclude il tempo impostato viene emesso un segnale acustico.

Fase 3 Premete un tasto qualsiasi per disattivare il segnale.

Fase 4 Ruotare la manopola fino a portarla alla posizione di spegnimento.

Come annullare: Funzioni dell'orologio

Fase 1  - premere ripetutamente fino a quando il simbolo della funzione orologio inizia a lampeggiare.

Fase 2 Premere e tenere premuto: .
La funzione orologio si disattiva dopo pochi secondi.

8. UTILIZZO DEGLI ACCESSORI



AVVERTENZA!

Fare riferimento ai capitoli sulla sicurezza.

8.1 Inserimento di accessori

Un piccolo rientro sulla parte superiore aumenta il livello di sicurezza. Gli incavi

fungono anche da dispositivi antibaltamento. Il bordo alto intorno al ripiano evita che le pentole scivolino dal ripiano.

Griglia:

Spingere il ripiano fra le guide del supporto.

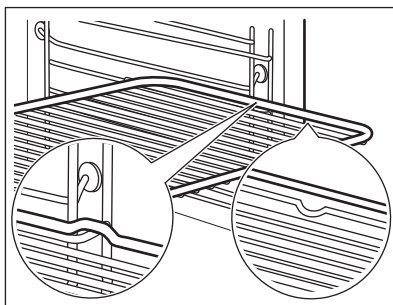
**Lamiera dolci /Leccarda:**

Spingere la lamiera tra le guide del supporto ripiano.

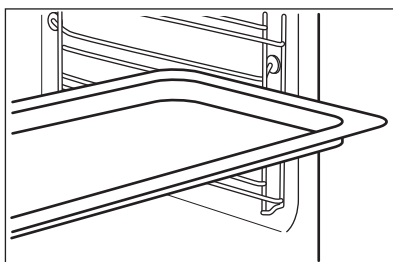
**Griglia, Lamiera dolci /Leccarda:**

Spingere il vassoio tra le guide del supporto ripiano e il ripiano a filo sulle guide sovrastanti.

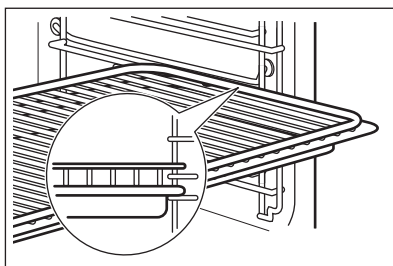

9. FUNZIONI AGGIUNTIVE

9.1 Ventola di raffreddamento

Quando il forno è in funzione, la ventola di raffreddamento si accende in modo automatico per tenere fresche le superfici del

forno. Dopo aver spento il forno, la ventola di raffreddamento potrebbe continuare a funzionare fino a che il forno non si è raffreddato.

10. CONSIGLI E SUGGERIMENTI UTILI



Fare riferimento ai capitoli sulla sicurezza.

10.1 Consigli di cottura



La temperatura ed i tempi di cottura specificati nelle tabella sono valori indicativi. Possono variare in base alle ricette, alla qualità e alla quantità degli ingredienti utilizzati.

Il vostro nuovo forno può cuocere o arrostito in modo differente rispetto al forno posseduto in precedenza. Le seguenti tabelle mostrano le impostazioni consigliate per temperatura, tempo di cottura e ripiano griglia per determinate tipologie di cibo.

Qualora non si trovino le impostazioni per una ricetta speciale, cercarne una simile.

10.2 Lato interno della porta

Nella parte interna del forno si trova:

- i numeri delle posizioni della griglia.
- Informazioni sulle funzioni forno, posizioni della griglia e temperature consigliate per alcune pietanze.

10.3 Panificare

Per la prima cottura, usare la temperatura più bassa.

È possibile estendere i tempi di cottura di 10 – 15 minuti se si cuociono torte su più di una posizione di ripiano.





Torte e dolci a diverse altezze non si dorano in modo equivalente. Non occorre modificare l'impostazione di temperatura se si verifica una doratura non identica. Le differenze si livellano durante la cottura.

I vassoi nel forno possono distorcersi durante la cottura. Quando si raffreddano nuovamente, le distorsioni scompaiono.

10.4 Suggerimenti sulla cottura

Risultati di cottura	Causa possibile	Rimedio
Il fondo della torta non è cotto a sufficienza.	La posizione del ripiano non è corretta.	Mettere la torta nel ripiano inferiore.
La torta si affloscia e diventa inzuppata o striata.	La temperatura del forno è troppo alta.	La prossima volta impostare la temperatura del forno leggermente inferiore.
	La temperatura del forno è troppo alta e il tempo di cottura troppo corto.	La prossima volta impostare un tempo di cottura più lungo e una temperatura del forno inferiore.
La torta è troppo asciutta.	La temperatura del forno è troppo bassa.	La prossima volta impostare una temperatura del forno superiore.
	Il tempo di cottura è troppo lungo.	La prossima volta impostare un tempo di cottura più breve.
La torta si cuoce in modo non uniforme.	La temperatura del forno è troppo alta e il tempo di cottura troppo corto.	La prossima volta impostare un tempo di cottura più lungo e una temperatura del forno inferiore.
	La pastella della torta non è distribuita in modo uniforme.	La prossima volta distribuire la pastella della torta in modo uniforme nella tortiera.
La torta non è pronta nel tempo di cottura specificato nella ricetta.	La temperatura del forno è troppo bassa.	La prossima volta impostare una temperatura del forno leggermente superiore.



10.5 Cottura su un solo livello ripiano

 COTTURA IN STAMPI		 (°C)	 (min)	
Base per flan – pasta frolla, preriscaldare il forno vuoto	Cottura ventilata	170 - 180	10 - 25	2
Base per flan - impasto per torte lievitate	Cottura ventilata	150 - 170	20 - 25	2
Ciambella / Brioches	Cottura ventilata	150 - 160	50 - 70	1
Pan di Spagna / Torte alla frutta	Cottura ventilata	140 - 160	70 - 90	1
Cheesecake	Cottura convenzionale	170 - 190	60 - 90	1

Utilizzare la posizione del terzo ripiano.

Utilizzare la funzione: Cottura ventilata.





Usare una piastra di cottura.





 TORTE / DOLCI / PANE	 (°C)	 (min)
Dolce secco con granelli di zucchero	150 - 160	20 - 40
Torte di frutta (realizzati con pasta lievitata/pasta frolla), utilizzare una leccarda	150	35 - 55
Flan di frutta fatte con pasta frolla	160 - 170	40 - 80

Preriscaldare il forno vuoto.





Utilizzare la funzione: Cottura convenzionale.

Usare una piastra di cottura.

 TORTE / DOLCI / PANE	 (°C)	 (min)	
Rotolo con marmellata	180 - 200	10 - 20	3
Pane di segale:	prima: 230	20	1
	poi: 160 - 180	30 - 60	
Torta al burro di mandorle / Torta zuccherata	190 - 210	20 - 30	3
Bignè / Eclair	190 - 210	20 - 35	3
Treccia / Corona di pane	170 - 190	30 - 40	3





 TORTE / DOLCI / PANE	 (°C)	 (min)	
Torte di frutta (realizzati con pasta lievitata/pasta frolla), utilizzare una leccarda	170	35 - 55	3
Ciambelle lievitate guarnite (ad es. con formaggio morbido, panna, crema)	160 - 180	40 - 80	3
Christstollen	160 - 180	50 - 70	2





Utilizzare la posizione del terzo ripiano.

 BISCOTTI		 (°C)	 (min)
Biscotti di pasta frolla	Cottura ventilata	150 - 160	10 - 20
Panini, preriscaldare il forno vuoto	Cottura ventilata	160	10 - 25
Biscotti realizzati con pasta lievitata	Cottura ventilata	150 - 160	15 - 20
Pasticcini di pasta sfoglia, preriscaldare il forno vuoto	Cottura ventilata	170 - 180	20 - 30
Biscotti realizzati con pasta lievitata	Cottura ventilata	150 - 160	20 - 40
Macarons	Cottura ventilata	100 - 120	30 - 50
Pasta fatti con bianco d'uovo / Meringhe	Cottura ventilata	80 - 100	120 - 150
Panini, preriscaldare il forno vuoto	Cottura convenzionale	190 - 210	10 - 25

10.6 Sformati e gratinati

Utilizzare la posizione del primo ripiano.





		 (°C)	 (min)
Baguette con formaggio fuso	Cottura ventilata	160 - 170	15 - 30
Gratin di verdure, preriscaldare il forno vuoto	Turbo Grill	160 - 170	15 - 30
Lasagne	Cottura convenzionale	180 - 200	25 - 40
Sformati di pesce	Cottura convenzionale	180 - 200	30 - 60
Verdure farcite	Cottura ventilata	160 - 170	30 - 60





		 (°C)	 (min)
Dolci al forno	Cottura convenzionale	180 - 200	40 - 60
Pasta al forno	Cottura convenzionale	180 - 200	45 - 60

10.7 Cottura multilivello

Utilizzare la funzione: Cottura ventilata.

Usare le piastre.

 TORTE/ DOLCI	 (°C)	 (min)	 2 posizioni
Bigné / Eclair, preriscaldare il forno vuoto	160 - 180	25 - 45	1 / 4
Torta Streusel	150 - 160	30 - 45	1 / 4

 BI- SCOTTI / TORTE PICCOLE / PASTA / ROLL	 (°C)	 (min)	 2 posizioni	 3 posizioni
Panini	180	20 - 30	1 / 4	-
Biscotti di pasta frolla	150 - 160	20 - 40	1 / 4	1 / 3 / 5
Biscotti realizzati con pasta lievitata	160 - 170	25 - 40	1 / 4	-
Pasticcini di pasta sfoglia, preriscaldare il forno vuoto	170 - 180	30 - 50	1 / 4	-
Biscotti realizzati con pasta lievitata	160 - 170	30 - 60	1 / 4	-
Macarons	100 - 120	40 - 80	1 / 4	-
Biscotti fatti con bianco d'uovo / Meringhe	80 - 100	130 - 170	1 / 4	-

10.8 Suggerimenti per l'arrostitura

Utilizzare pentolame da forno resistente al calore.

Arrostire la carne magra coperta (è possibile usare pellicola di alluminio).

Arrostire grandi pezzi di carne direttamente nel vassoio o sulla griglia posta sopra il vassoio.

Mettere un po' d'acqua nel vassoio onde evitare la bruciatura del grasso che cola.







Girare l'arrosto dopo 1/2 - 2/3 del tempo di cottura.







Arrostire la carne e il pesce in pezzi di grandi dimensioni (1 kg o più).

Ungere diverse volte i pezzi di carne con il proprio sugo durante l'arrostimento.

10.9 Cottura arrosto

Utilizzare la posizione del primo ripiano.

 MANZO				 (°C)	 (min.)
Arrosto misto	1 - 1,5 kg	Cottura convenzionale	230	120 - 150	
Roastbeef o filetto al sangue, preriscaldare il forno vuoto	per cm di altezza	Turbo Grill	190 - 200	5 - 6	
Roastbeef o filetto, cottura media, preriscaldare il forno vuoto	per cm di altezza	Turbo Grill	180 - 190	6 - 8	
Roastbeef o filetto, ben cotto, preriscaldare il forno vuoto	per cm di altezza	Turbo Grill	170 - 180	8 - 10	

 MAIALE		 (kg)	 (°C)	 (min.)
 Utilizzare la funzione: Turbo Grill.				
Spalla / Coppa / Coscia	1 - 1.5	160 - 180	90 - 120	
Bracirole / Costoletta di maiale	1 - 1.5	170 - 180	60 - 90	
Polpettone di carne	0.75 - 1	160 - 170	50 - 60	
Stinco di maiale, precotto	0.75 - 1	150 - 170	90 - 120	



VITELLO



Utilizzare la funzione: Turbo Grill.



(kg)



(°C)



(min.)

Arrostito di vitello	1	160 - 180	90 - 120
Stinco di vitello	1.5 - 2	160 - 180	120 - 150



AGNELLO



Utilizzare la funzione: Turbo Grill.



(kg)



(°C)



(min.)

Coscia d'agnello / Arrostito di agnello	1 - 1.5	150 - 170	100 - 120
Sella d'agnello	1 - 1.5	160 - 180	40 - 60



SELVAGGINA



Utilizzare la funzione: Cottura convenzionale.



(kg)



(°C)



(min.)

Sella / Coscia di lepre, preriscaldare il forno vuoto	fino a 1	230	30 - 40
Sella di cervo	1.5 - 2	210 - 220	35 - 40
Coscia di capriolo	1.5 - 2	180 - 200	60 - 90



POLLAME



Utilizzare la funzione: Turbo Grill.



(kg)



(°C)



(min.)

	(kg)	(°C)	(min.)
Pollame, porzioni	0,2 - 0,25 ciascuno	200 - 220	30 - 50
Mezzo pollo	0,4 - 0,5 ciascuno	190 - 210	35 - 50
Pollo, pollastra	1 - 1,5	190 - 210	50 - 70
Anatra	1,5 - 2	180 - 200	80 - 100
Oca	3,5 - 5	160 - 180	120 - 180
Tacchino	2,5 - 3,5	160 - 180	120 - 150
Tacchino	4 - 6	140 - 160	150 - 240



PESCE (STUFATO)



Utilizzare la funzione: Cottura convenzionale.



(kg)



(°C)



(min.)

	(kg)	(°C)	(min.)
Pesce intero	1 - 1,5	210 - 220	40 - 60

10.10 Cottura croccante con: Funzione Pizza



IMPOSTAZIONE



Utilizzare la posizione del primo ripiano.



(°C)



(min.)

	(°C)	(min.)
Torte	180 - 200	40 - 55
Flan agli spinaci	160 - 180	45 - 60



IMPOSTAZIONE



Utilizzare la posizione del primo ripiano.



(°C)



(min.)

	(°C)	(min.)
Quiche lorraine / Flan al formaggio	170 - 190	45 - 55
Cheesecake	140 - 160	60 - 90
Torta di verdure	160 - 180	50 - 60



IMPOSTAZIONE



Preriscaldare il forno vuoto prima di iniziare a utilizzarlo.



Utilizzare la posizione del secondo ripiano.



(°C)



(min.)

Pizza, sottile,
utilizzare una
leccarda

200 - 230

15 - 20

Pizza, spessa

180 - 200

20 - 30

Pane non lievito

230 - 250

10 - 20

Torta di pasta
frolla

160 - 180

45 - 55

Flammkuchen

230 - 250

12 - 20



IMPOSTAZIONE



Preriscaldare il forno vuoto prima di iniziare a utilizzarlo.



Utilizzare la posizione del secondo ripiano.



(°C)



(min.)

Pierogi

180 - 200

15 - 25

10.11 Grill

Preriscaldare il forno vuoto prima di iniziare a utilizzarlo.

Cuocere al grill solo pezzi di carne o pesce sottili.

Mettere una pentola sulla posizione del primo ripiano per raccogliere i grassi.



GRILL



Utilizzare la funzione: Grill



(°C)



(min.)
1° lato



(min.)
2° lato



Roast beef

210 - 230

30 - 40

30 - 40

2

Filetto di manzo

230

20 - 30

20 - 30

3

Carré

210 - 230

30 - 40

30 - 40

2

Lonza di vitello

210 - 230

30 - 40

30 - 40

2

Sella d'agnello

210 - 230

25 - 35

20 - 25

3

Pesce intero, 0,5 kg -
1 kg

210 - 230

15 - 30

15 - 30

3 / 4

10.12 Cibi congelati



SBRINAMENTO



Utilizzare la funzione: **Cottura ventilata.**



(°C)



(min.)



	(°C)	(min.)	
Pizza surgelata	200 - 220	15 - 25	2
Pizza Americana surgelata	190 - 210	20 - 25	2
Pizza fredda	210 - 230	13 - 25	2
Pizzette surgelate	180 - 200	15 - 30	2
Patatine fritte sottili	200 - 220	20 - 30	3
Patatine fritte tagliate spesse	200 - 220	25 - 35	3
Patate a spicchi / Crocchette	220 - 230	20 - 35	3
Sformato di patate	210 - 230	20 - 30	3
Lasagne / Cannelloni, freschi	170 - 190	35 - 45	2
Lasagne / Cannelloni, surgelati	160 - 180	40 - 60	2
Cheesecake cotta	170 - 190	20 - 30	3
Ali di pollo	190 - 210	20 - 30	2

10.13 Scongellamento

Rimuovere gli alimenti dall'imballaggio e metterli su una piastra.

Non coprire il cibo, in quanto ciò può prolungare il tempo di sbrinamento.

Per grandi porzioni di cibo posizionare una piastra vuota capovolta sul fondo della cavità

Usare il primo livello griglia.

del forno. Mettere il cibo in un piatto profondo e collocarlo sulla parte superiore della piastra all'interno del forno. Se necessario, rimuovere i supporti del ripiano.



(kg)



(min)

Tempo di scongelamento







(min)

Ulteriore tempo di sbrinamento



	(kg)	(min) Tempo di scongelamento	(min) Ulteriore tempo di sbrinamento	
Pollo	1	100 - 140	20 - 30	Girare a metà tempo.
Carne	1	100 - 140	20 - 30	Girare a metà tempo.
Trota	0,15	25 - 35	10 - 15	-

	 (kg)	 (min) Tempo di scongelamento	 (min) Ulteriore tempo di sbrinamento	
Fragole	0,3	30 - 40	10 - 20	-
Burro	0,25	30 - 40	10 - 15	-
Panna	2 x 0,2	80 - 100	10 - 15	Frustare la crema quando ancora leggermente congelata in alcune zone.
Dolce	1,4	60	60	-

10.14 Marmellate/Conserve

Utilizzare la funzione Resistenza inferiore.

Utilizzare esclusivamente vasi da conserva delle stesse dimensioni disponibili sul mercato.

Non utilizzare vasi con coperchi a scatto o a baionetta o lattine metalliche.

Utilizzare la posizione del primo ripiano.

Non collocare più di 6 vasi da conserva da un litro sul vassoio di cottura.

Riempire i vasi in modo equo e chiudere con un morsetto.

I vasi non devono toccarsi tra loro.

Mettere circa 1/2 litro d'acqua nel vassoio di cottura per fornire sufficiente umidità al forno.

Quando il liquido nei vasi inizia a sobbollire (dopo circa 35 - 60 minuti con vasi da un litro), spegnere il forno o diminuire la temperatura a 100°C (vedere la tabella).

Impostare la temperatura a 160 - 170 °C.



**FRUTTA MOR-
BIDA**



(min)
Tempi di cottura fino alla comparsa delle prime bollicine

Fragole / Mirtilli / Lamponi / Uva spina matura



DRUPA



(min)
Tempi di cottura fino alla comparsa delle prime bollicine



(min)
Tempi di cottura restanti a 100°C

Pesche / Mele cotogne / Prugne

35 - 45

10 - 15



**VER-
DURE**



(min)
Tempi di cottura fino alla comparsa delle prime bollicine



(min)
Tempi di cottura restanti a 100°C

Carote

50 - 60

5 - 10

Cetrioli

50 - 60

-

Ortaggi misti in agrodolce

50 - 60

5 - 10

Cavolo rapa / Piselli / Asparagi

50 - 60

15 - 20

10.15 Essicatura - Cottura ventilata



Ricoprire le teglie con carta oleata o con carta da forno.



Per ottenere risultati migliori, spegnere il forno a metà del tempo consigliato, aprire la

porta e lasciare raffreddare per una notte per completare l'essiccazione.



Per 1 vassoio usare la terza posizione ripiano.

Per 2 vassoi usare la prima e quarta posizione ripiano.

 VERDURE	 (°C)	 (ore)
Fagioli	60 - 70	6 - 8
Peperoni	60 - 70	5 - 6
Verdure per minestrone	60 - 70	5 - 6
Funghi	50 - 60	6 - 8

 VERDURE	 (°C)	 (ore)
Erbette	40 - 50	2 - 3

Impostare la temperatura a 60 - 70 °C.

 FRUTTA	 (ore)
Prugne	8 - 10
Albicocche	8 - 10
Fette di mela	6 - 8
Pere	6 - 9

10.16 Cottura ventilata umida - accessori consigliati

Usare scatole e contenitori scuri e non riflettenti. Assorbono meglio il calore rispetto al colore chiaro e ai piatti riflettenti.



Teglia da pizza

Scura, non riflettente
28 cm di diametro

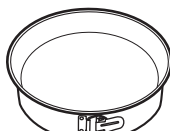

Pirofila

Scura, non riflettente
26 cm di diametro



Pirofile monoporzione

Ceramica
diametro 8 cm, altezza 5 cm











Tortiera per flan

Scura, non riflettente
28 cm di diametro

10.17 Cottura ventilata umida







Per ottenere i risultati migliori, attenersi ai suggerimenti elencati nella tabella sottostante.







	 (°C)	 (min.)	
Grissini, 0,5 kg in totale	190 - 200	50 - 60	3
Capesante cotte	180 - 200	30 - 40	4
Pesce intero in sale, 0,3 - 0,5 kg	190 - 200	45 - 50	4
Pesce intero in carta da forno, 0,3 - 0,5 kg	190 - 200	50 - 60	3
Amaretti (20; 0,5 kg in totale)	170 - 180	40 - 50	3

	 (°C)	 (min.)	
Gratin di mele	190 - 200	50 - 60	4
Muffin al cioccolato (20; 0,5 kg in totale)	160 - 170	35 - 45	3

10.18 Informazioni per gli istituti di prova

Test conformemente a: EN 60350, IEC 60350.

 COTTURA SU UN LIVELLO Cottura in stampi				
		 (°C)	 (min)	
Pan di Spagna senza grassi	Cottura ventilata	140 - 150	35 - 50	2
Pan di Spagna senza grassi	Cottura convenzionale	160	35 - 50	2
Torta di mele, 2 stampi Ø20 cm	Cottura ventilata	160	60 - 90	2
Torta di mele, 2 stampi Ø20 cm	Cottura convenzionale	180	70 - 90	1

 COTTURA SU UN LIVELLO Biscotti				
 Utilizzare la posizione del terzo ripiano.				
		 (°C)	 (min)	
Frollini al burro / Strisce di pasta	Cottura ventilata	140	25 - 40	
Frollini al burro / Strisce di pasta, preriscaldare il forno vuoto	Cottura convenzionale	160	20 - 30	
Dolcetti, 20 per lamiera dolci, preriscaldare il forno vuoto	Cottura ventilata	150	20 - 35	
Dolcetti, 20 per lamiera dolci, preriscaldare il forno vuoto	Cottura convenzionale	170	20 - 30	



COTTURA MULTILIVELLO. Biscotti



(°C)



(min)



Frollini al burro / Strisce di pasta

Cottura ventilata

140

25 - 45

1 / 4

Dolcetti, 20 per lamiera dolci, preriscaldare il forno vuoto

Cottura ventilata

150

23 - 40

1 / 4

Pan di Spagna senza grassi

Cottura ventilata

160

35 - 50

1 / 4



GRILL



Preriscaldare il forno vuoto per 5 minuti.



Grigliare con l'impostazione di temperatura massima.



(min)



Toast

Grill

1 - 3

5

Bistecca di manzo, girare il piatto a metà tempo

Grill

24 - 30

4

11. PULIZIA E CURA



AVVERTENZA!

Fare riferimento ai capitoli sulla sicurezza.

11.1 Note sulla pulizia



Pulire la parte anteriore del forno con un panno morbido imbevuto di acqua tiepida e detergente delicato.

Servirsi di una soluzione detergente per pulire le superfici metalliche.

Pulire le macchie con un detergente delicato.

Agenti di pulizia



Uso quotidiano

Pulire la cavità dopo ogni utilizzo. L'accumulo di grasso o di altri residui potrebbe causare un incendio.

Non lasciare le vivande nel forno per più di 20 minuti. Asciugare la cavità con un panno morbido dopo ogni uso.



Accessori

Pulire tutti gli accessori dopo ogni uso e lasciarli asciugare. Utilizzare un panno morbido imbevuto di acqua tiepida e un detergente delicato. Non pulire gli accessori in lavastoviglie.

Non pulire gli accessori anti-aderenti con agenti abrasivi o oggetti appuntiti.

11.2 Come togliere: Supporti ripiano

Rimuovere i supporti ripiano per pulire il forno.

Fase 1 Spegner il forno e attendere che sia freddo.

Fase 2 Sfilare dapprima la guida di estrazione dalla parete laterale tirandola in avanti.

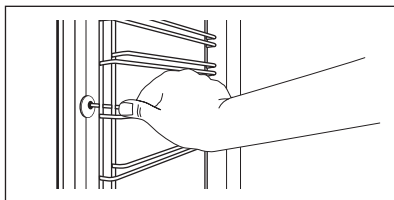

Fase 3 Sfilare la guida di estrazione posteriore dalla parete laterale e toglierla.

Fase 4 Installare i supporti griglia seguendo al contrario la procedura indicata.

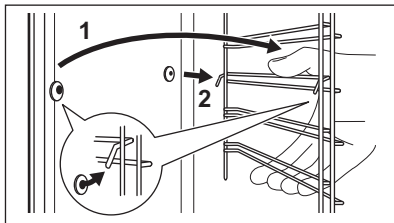

11.3 Come togliere: Grill



AVVERTENZA!

Pericolo di ustione.

- Fase 1** Spegner il forno e attendere che sia freddo per pulirlo.
Rimuovere i supporti ripiano.
- Fase 2** Tirarlo in avanti contro la molla a pressione ed estrarlo dai due supporti. La griglia si piega.
- Fase 3** Pulire la parte superiore del forno con acqua tiepida, un panno morbido e detergente delicato. Lasciare asciugare.
- Fase 4** Installare la griglia seguendo al contrario la procedura indicata.

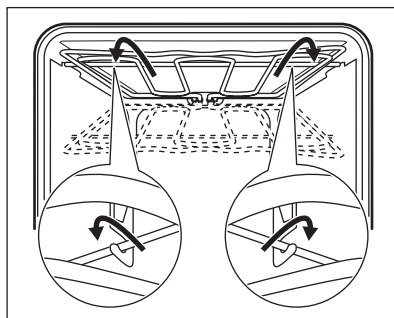

- Fase 5** Montare i supporti ripiano.

11.4 Come rimuovere e installare?

Il numero di pannelli in vetro varia a seconda dei modelli.



ATTENZIONE!

Maneggiare con cura il vetro, in particolare intorno ai bordi del pannello frontale. Il vetro può rompersi.

11.5 Come sostituire: Lampadina



AVVERTENZA!

Pericolo di scosse elettriche. La lampada potrebbe essere calda.

Prima di sostituire la lampadina:

Fase 1	Fase 2	Fase 3
Spegner il forno. Attendere che il forno sia freddo.	Estrarre la spina dalla presa di corrente.	Appoggiare un panno sul fondo della cavità.

Lampadina superiore

- Fase 1** Girare il rivestimento di vetro per toglierlo.

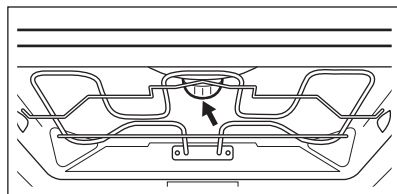

- Fase 2** Pulire il rivestimento di vetro.
- Fase 3** Sostituire la lampadina con una adatta, termoresistente fino a 300 °C.
- Fase 4** Installare la calotta di vetro.

12. RISOLUZIONE DEI PROBLEMI



AVVERTENZA!

Fare riferimento ai capitoli sulla sicurezza.

12.1 Cosa fare se...

In tutti i casi non inclusi in questa tabella si prega di contattare un Centro di Assistenza Autorizzato.

Problema	Controllare se...
Il forno non si scalda.	È scattato il fusibile.
Il display indica "12.00".	Si è verificata un'interruzione dell'alimentazione elettrica. Impostare l'ora.

Problema

Controllare se...

La lampadina non si accende.

La lampada è bruciata.

12.2 Dati Assistenza

Qualora non sia possibile trovare una soluzione al problema, contattare il rivenditore o il Centro di Assistenza Autorizzato.

Le informazioni necessarie per il Centro di Assistenza si trovano sulla targhetta dei dati. La targhetta si trova sul telaio anteriore del forno. Non rimuovere la targhetta dei dati dalla cavità del forno.

Consigliamo di annotarli in questo spazio:

Modello (MOD.)

Codice Prodotto (PNC)

Numero di serie (S.N.)

13. EFFICIENZA ENERGETICA

13.1 Informazioni sul prodotto e Scheda informativa sul prodotto*

Nome fornitore	AEG
Identificativo modello	BEK435220M 944188023
Indice di efficienza energetica	81.2
Classe di efficienza energetica	A+
Consumo di energia con un carico standard, in modalità tradizionali	0.99 kWh/ciclo
Consumo di energia con un carico standard, in modalità ventola forzata	0.69 kWh/ciclo
Numero di cavità	1
Fonte di calore	Elettricità
Volume	71 l
Tipo di forno	Forno a incasso
Massa	34.0 kg

* Per l'Unione europea secondo i regolamenti UE 65/2014 e 66/2014.
Per la Repubblica di Bielorussia ai sensi di STB 2478-2017, appendice G; STB 2477-2017, allegati A e B.
Per l'Ucraina secondo 568/32020.

La classe di efficienza energetica non è applicabile alla Russia.

EN 60350-1 - Apparecchiature elettriche per la cottura per uso domestico - Parte 1: Cucine, forni, forni a vapore e grill - Metodi per la misura delle prestazioni.

13.2 Risparmio energetico



Il forno è dotato di funzioni che consentono di aiutarvi a risparmiare energia durante le operazioni di cottura di tutti i giorni.

Verificare che la porta del forno sia chiusa quando lo stesso è in funzione. Non aprire la porta del forno con eccessiva frequenza in fase di cottura. Tenere pulita la guarnizione della porta e verificare che sia saldamente fissata in posizione.

Servirsi di pentole in metallo per migliorare il risparmio energetico.

Ove possibile, non pre-riscaldare il forno prima della cottura.

Ridurre quanto più possibile gli intervalli fra le diverse operazioni di cottura quando vengono preparati più piatti contemporaneamente.

Cucinare con ventola

Ove possibile, servirsi delle funzioni di cottura con la ventola per risparmiare energia.

Calore residuo

Quando la durata di cottura è superiore ai 30 minuti, ridurre la temperatura del forno al minimo 3-10 minuti prima della fine del processo di cottura. Il calore residuo all'interno del forno proseguirà la cottura.

Utilizzare il calore residuo per scaldare altri piatti.

Tenere in caldo gli alimenti

Scegliere l'impostazione di temperatura più bassa per usare il calore residuo e tenere calda la pietanza.

Cottura ventilata umida

Funzione progettata per risparmiare energia in fase di cottura.

14. CONSIDERAZIONI SULL'AMBIENTE

Riciclare i materiali con il simbolo . Buttare l'imballaggio negli appositi contenitori per il riciclaggio. Aiutare a proteggere l'ambiente e la salute umana e a riciclare rifiuti derivanti da apparecchiature elettriche ed elettroniche. Non smaltire le apparecchiature che

riportano il simbolo  insieme ai normali rifiuti domestici. Portare il prodotto al punto di riciclaggio più vicino o contattare il comune di residenza.

PARA OBTENER RESULTADOS PERFECTOS

Gracias por escoger este producto AEG. Este artículo ha sido creado para ofrecer un rendimiento impecable durante muchos años, con innovadoras tecnologías que facilitarán su vida y prestaciones que probablemente no encuentre en electrodomésticos corrientes. Por favor, dedique algunos minutos a la lectura para disfrutar de todas sus ventajas.

Visite nuestro sitio web para:



Obtener consejos, folletos, soluciones a problemas e información de servicio y reparación:

www.aeg.com/support



Registrar su producto para recibir un mejor servicio:

www.registreaeg.com



Adquirir accesorios, artículos de consumo y recambios originales para su aparato:

www.aeg.com/shop

ATENCIÓN Y SERVICIO AL CLIENTE

Le recomendamos que utilice recambios originales.

Al contactar con nuestro centro autorizado de servicio técnico, cerciórese de tener la siguiente información a mano: Modelo, PNC, Número de serie.

La información se puede encontrar en la placa de características.

 Advertencia / Precaución-Información sobre seguridad

 Información general y consejos

 Información sobre el medio ambiente

Salvo modificaciones.

CONTENIDO

1. INFORMACIÓN SOBRE SEGURIDAD.....	111
2. INSTRUCCIONES DE SEGURIDAD.....	113
3. DESCRIPCIÓN DEL PRODUCTO.....	116
4. PANEL DE MANDOS.....	116
5. ANTES DEL PRIMER USO.....	117
6. USO DIARIO.....	118
7. FUNCIONES DEL RELOJ.....	119
8. USO DE LOS ACCESORIOS.....	120
9. FUNCIONES ADICIONALES.....	121
10. CONSEJOS.....	121
11. MANTENIMIENTO Y LIMPIEZA.....	134
12. SOLUCIÓN DE PROBLEMAS.....	136
13. EFICACIA ENERGÉTICA.....	136

1. INFORMACIÓN SOBRE SEGURIDAD

Antes de instalar y utilizar el aparato, lea atentamente las instrucciones facilitadas. El fabricante no se hace

responsable de lesiones o daños producidos como resultado de una instalación o un uso incorrectos. Conserve siempre estas instrucciones en lugar seguro y accesible para futuras consultas.

1.1 Seguridad de niños y personas vulnerables

- Este aparato puede ser utilizado por niños de 8 años en adelante y personas cuyas capacidades físicas, sensoriales o mentales estén disminuidas o que carezcan de la experiencia y conocimientos suficientes para manejarlo, siempre que cuenten con las instrucciones o la supervisión sobre el uso del electrodoméstico de forma segura y comprendan los riesgos. Hay que mantener alejados del producto a los niños de menos de 8 años, así como a las personas con minusvalías importantes y complejas, salvo que estén bajo supervisión continua.
- No deje que los niños jueguen con el aparato.
- Mantenga todo el material de embalaje fuera del alcance de los niños y deséchelo de forma adecuada.
- **ADVERTENCIA:** Mantenga a los niños y mascotas alejados del aparato cuando esté funcionando o enfriándose. Las partes accesibles se calientan durante el uso.
- Si este aparato tiene un bloqueo de seguridad para niños, debe activarlo.
- La limpieza y mantenimiento de usuario del aparato no podrán ser realizados por niños sin supervisión.

1.2 Seguridad general

- Solo un electricista cualificado puede instalar este aparato y sustituir el cable.
- **ADVERTENCIA:** El aparato y las piezas accesibles se calientan mucho durante el funcionamiento. Preste mucha atención para no tocar las resistencias.
- Utilice siempre guantes de horno cuando introduzca o retire accesorios o utensilios refractarios.
- Antes de realizar tareas de mantenimiento, desenchufe el aparato de la red eléctrica.

- **ADVERTENCIA:** Asegúrese de que el aparato está desconectado antes de reemplazar la lámpara con el fin de impedir que se produzca una descarga eléctrica.
- No utilice el aparato antes de instalarlo en la estructura empotrada.
- No utilice un limpiador a vapor para limpiar el aparato.
- No utilice limpiadores abrasivos ásperos ni rascadores de metal afilado para limpiar la puerta de cristal si no quiere arañar su superficie, lo que podría hacer que el cristal se hiciese añicos.
- Si el cable de alimentación eléctrica sufre algún daño, el fabricante, su servicio técnico autorizado o un profesional cualificado tendrán que cambiarlo para evitar riesgos eléctricos.
- Para quitar los carriles laterales, tire primero del frontal del carril y luego separe el extremo trasero de las paredes. Coloque los carriles laterales en el orden inverso.

2. INSTRUCCIONES DE SEGURIDAD

2.1 Instalación



ADVERTENCIA!

Sólo un técnico cualificado puede instalar el aparato.

- Retire todo el embalaje.
- No instale ni utilice un aparato dañado.
- Siga las instrucciones de instalación suministradas con el aparato.
- Tenga cuidado al mover el aparato, porque es pesado. Utilice siempre guantes de protección y calzado cerrado.
- No tire nunca del aparato sujetando el asa.
- Instale el aparato en un lugar seguro y adecuado que cumpla los requisitos de instalación.
- Respete siempre la distancia mínima entre el aparato y los demás electrodomésticos y mobiliario.
- Antes de montar el aparato, compruebe si la puerta del horno se abre sin limitaciones.

- El aparato dispone de un sistema de enfriamiento eléctrico. Debe utilizarse con alimentación eléctrica.
- La unidad empotrada debe cumplir los requisitos de estabilidad de la norma DIN 68930.

Altura mínima del armario (Altura mínima del armario debajo de la encimera)	578 (600) mm
-----------------------------------------------------------------------------------	--------------

Ancho del armario	560 mm
-------------------	--------

Profundidad del armario	550 (550) mm
-------------------------	--------------

Altura de la parte frontal del aparato	594 mm
-------------------------------------------	--------

Altura de la parte trasera del aparato	576 mm
-------------------------------------------	--------

Anchura de la parte frontal del aparato	595 mm
--------------------------------------------	--------

Anchura de la parte trasera del aparato	559 mm
--------------------------------------------	--------

Fondo del aparato	567 mm
-------------------	--------

Fondo empotrado del aparato	546 mm
Fondo con la puerta abierta	1027 mm
Tamaño mínimo de la abertura de ventilación. Abertura situada en la parte trasera inferior	560 x 20 mm
Longitud del cable de alimentación. El cable está en la esquina derecha de la parte trasera	1500 mm
Tornillos de montaje	4 x 25 mm

2.2 Conexión eléctrica



ADVERTENCIA!

Riesgo de incendios y descargas eléctricas.

- Todas las conexiones eléctricas deben realizarlas electricistas cualificados.
- El aparato debe conectarse a tierra.
- Asegúrese de que los parámetros de la placa de características son compatibles con los valores eléctricos del suministro eléctrico.
- Utilice siempre una toma con aislamiento de conexión a tierra correctamente instalada.
- No utilice adaptadores de enchufes múltiples ni cables prolongadores.
- Asegúrese de no provocar daños en el enchufe ni en el cable de red. Si es necesario cambiar el cable de alimentación del aparato, debe hacerlo el centro de servicio técnico autorizado.
- Evite que el cable de red toque o entre en contacto con la puerta del aparato o con el hueco por debajo del aparato, especialmente mientras funciona o si la puerta está caliente.
- Los mecanismos de protección contra descargas eléctricas de componentes con corriente y aislados deben fijarse de forma que no puedan aflojarse sin utilizar herramientas.
- Conecte el enchufe a la toma de corriente únicamente cuando haya terminado la instalación. Asegúrese de tener acceso al enchufe del suministro de red una vez finalizada la instalación.

- Si la toma de corriente está floja, no conecte el enchufe.
- No desconecte el aparato tirando del cable de conexión a la red. Tire siempre del enchufe.
- Use únicamente dispositivos de aislamiento apropiados: línea con protección contra los cortocircuitos, fusibles (tipo tornillo que puedan retirarse del soporte), dispositivos de fuga a tierra y contactores.
- La instalación eléctrica debe tener un dispositivo de aislamiento que permita desconectar el aparato de todos los polos de la red. El dispositivo de aislamiento debe tener una apertura de contacto con una anchura mínima de 3 mm.
- El aparato se suministra con enchufe y cable de red.

2.3 Uso del aparato



ADVERTENCIA!

Riesgo de lesiones, quemaduras y descargas eléctricas o explosiones.

- Este aparato está diseñado exclusivamente para uso doméstico.
- No cambie las especificaciones de este aparato.
- Cerciórese de que los orificios de ventilación no están obstruidos.
- No deje nunca el aparato desatendido mientras está en funcionamiento.
- Desactive el aparato después de cada uso.
- Tenga cuidado al abrir la puerta del aparato cuando éste esté en funcionamiento. Pueden liberarse vapores calientes.
- No utilice el aparato con las manos mojadas ni cuando entre en contacto con el agua.
- No ejerza presión sobre la puerta abierta.
- No utilice el aparato como superficie de trabajo ni de almacenamiento.
- Abra la puerta del aparato con cuidado. El uso de ingredientes con alcohol puede generar una mezcla de alcohol y aire.
- Procure que no haya chispas ni fuego encendido cerca cuando se abra la puerta del aparato.
- No coloque productos inflamables ni objetos mojados con productos

inflamables dentro, cerca o encima del aparato.



ADVERTENCIA!

Podría dañar el aparato.

- Para evitar daños o decoloraciones del esmalte:
 - no coloque utensilios refractarios ni otros objetos directamente en la parte inferior del aparato.
 - no coloque papel de aluminio directamente en la parte inferior del interior del aparato.
 - No ponga agua directamente en el aparato caliente.
 - No deje platos húmedos ni comida en el aparato una vez finalizada la cocción.
 - Preste especial atención al desmontar o instalar los accesorios.
- La pérdida de color del esmalte o el acero inoxidable no afecta al rendimiento del aparato.
- Utilice una bandeja honda para pasteles húmedos. Los jugos de las frutas podrían ocasionar manchas permanentes.
- Este aparato está diseñado exclusivamente para cocinar. No debe utilizarse para otros fines, por ejemplo, como calefacción.
- Cocine siempre con la puerta del horno cerrada.
- Si el aparato se instala detrás de un panel de un mueble (por ejemplo una puerta) asegúrese de que la puerta nunca esté cerrada mientras funciona el aparato. El calor y la humedad pueden acumularse detrás de un panel del armario cerrado y provocar daños al aparato, la unidad donde se encuentra o el suelo. No cierre del panel del armario hasta que el aparato se haya enfriado totalmente después de su uso.

2.4 Mantenimiento y limpieza



ADVERTENCIA!

Existe riesgo de lesiones, incendios o daños al aparato.

- Antes de proceder con el mantenimiento, apague el aparato y desconecte el enchufe de la red.
- Asegúrese de que el aparato esté frío. Los paneles de cristal pueden romperse.

- Cambie inmediatamente los paneles de cristal de la puerta que estén dañados. Póngase en contacto con el servicio técnico autorizado.
- Limpie periódicamente el aparato para evitar el deterioro del material de la superficie.
- Limpie el aparato con un paño suave humedecido. Utilice solo detergentes neutros. No utilice productos abrasivos, estropajos duros, disolventes ni objetos metálicos.
- Si utiliza aerosoles de limpieza para hornos, siga las instrucciones de seguridad del envase.

2.5 Luces interiores



ADVERTENCIA!

Riesgo de descarga eléctrica.

- En cuanto a la(s) bombilla(s) de este producto y las de repuesto vendidas por separado: Estas bombillas están destinadas a soportar condiciones físicas extremas en los aparatos domésticos, como la temperatura, la vibración, la humedad, o están destinadas a señalar información sobre el estado de funcionamiento del aparato. No están destinadas a utilizarse en otras aplicaciones y no son adecuadas para la iluminación de estancias domésticas.
- Utilice solo bombillas de las mismas características .

2.6 Asistencia

- Para reparar el aparato, póngase en contacto con el centro de servicio autorizado.
- Utilice solamente piezas de recambio originales.

2.7 Eliminación



ADVERTENCIA!

Existe riesgo de lesiones o asfixia.

- Desconecte el aparato de la red.
- Corte el cable eléctrico cerca del aparato y deséchelo.
- Retire el pestillo de la puerta para evitar que los niños las mascotas queden atrapados en el aparato.

3. DESCRIPCIÓN DEL PRODUCTO

3.1 Descripción general

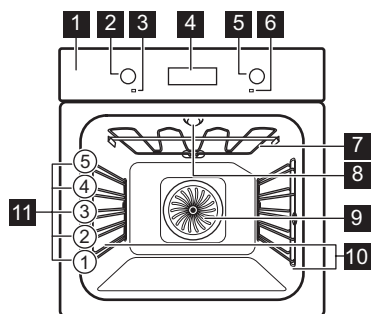

- 1 Panel de control
- 2 Mando de las funciones de cocción
- 3 Piloto/símbolo de alimentación
- 4 Pantalla
- 5 Mando de en control (de la temperatura)
- 6 Indicador/símbolo de temperatura
- 7 Resistencia
- 8 Bombilla
- 9 Ventilador
- 10 Carril lateral, extraíble
- 11 Posiciones de los estantes

3.2 Accesorios

Parrilla

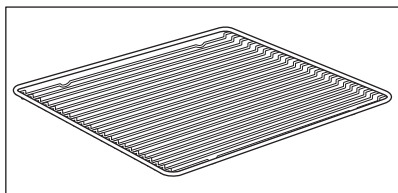

Para bandejas de horno, pastel en molde, asados.

Bandeja de cocción

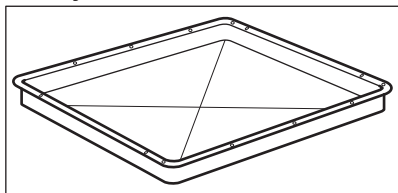

Para bizcochos y galletas.

Bandeja honda

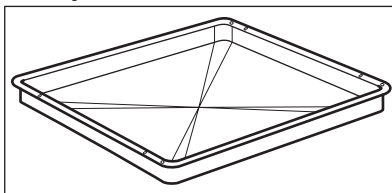

Para hornear y asar o como bandeja para grasa.

4. PANEL DE MANDOS

4.1 Mandos escamoteables

Para usar el aparato, presione el mando. El mando sale del alojamiento.

4.2 Sensores / botones

—	Para ajustar la hora.
	Para ajustar una función de reloj.
+	Para ajustar la hora.

4.3 Pantalla

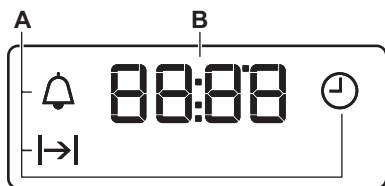

- A. Funciones del reloj
- B. Temporizador

5. ANTES DEL PRIMER USO



ADVERTENCIA!

Consulte los capítulos sobre seguridad.

5.1 Antes del primer uso

El horno puede emitir olores y humos durante el precalentamiento. Asegúrese de que la sala esté ventilada.







Paso 1



Paso 2



Paso 3

Ajuste el reloj	Limpie el horno	Precaliente el horno vacío
<ol style="list-style-type: none"> 1. Pulse: . 2. +, — - pulse para ajustar la hora. Pulse: . 3. +, — - pulse para ajustar los minutos. Pulse: . 	<ol style="list-style-type: none"> 1. Retire todos los accesorios y carriles de apoyo extraíbles del horno. 2. Limpie el horno y los accesorios con un paño suave humedecido en agua templada y jabón neutro. 	<ol style="list-style-type: none"> 1. Seleccione la temperatura máxima para la función: . Tiempo: 1 h. 2. Seleccione la temperatura máxima para la función: . Tiempo: 15 min.
<p>Apague el horno y espere a que esté frío. Coloque los accesorios y carriles de apoyo extraíbles en el horno.</p>		

6. USO DIARIO



ADVERTENCIA!

Consulte los capítulos sobre seguridad.

6.1 Cómo configurar: Función de cocción

- Paso 1** Gire el mando del horno para seleccionar una función de cocción.
- Paso 2** Gire el mando de control para seleccionar la temperatura.
- Paso 3** Al terminar la cocción, gire los mandos hasta la posición de apagado para apagar el horno.

6.2 Funciones de cocción

Función de cocción	Aplicación
0	El horno está apagado.
Posición de apagado	
	Para encender la luz.
Luz	
	Para hornear en hasta tres posiciones de parrilla a la vez y para secar alimentos. Ajuste la temperatura entre 20 y 40 °C menos que para Cocción convencional.
Aire caliente	
	Para hornear pizza. Para obtener un dorado más intenso y una base más crujiente
Función pizza	
	Para hornear y asar alimentos en una posición de bandeja.
Cocción convencional	
	Para preparar pasteles con bases crujientes y conservar alimentos.
Calor inferior	

Función de cocción	Aplicación
	Para descongelar alimentos (verdura y fruta). El tiempo de descongelación depende de la cantidad y tamaño de los alimentos congelados.
Descongelar	
	Función diseñada para ahorrar energía durante la cocción. Cuando se utiliza esta función, la temperatura del horno puede diferir de la temperatura programada. Se utiliza el calor residual. La potencia calorífica puede reducirse. Para más información, consulte el capítulo "Uso diario", Notas sobre: Horneado húmedo + ventil.
Horneado húmedo + ventil.	
	Para asar al grill alimentos de poco espesor y tostar pan.
Grill	
	Para asar piezas de carne grandes o aves con hueso en una posición de bandeja. Para hacer gratenes y dorar.
Grill Turbo	



La bombilla se puede apagar automáticamente a temperaturas inferiores a 60 °C durante algunas funciones del horno.

6.3 Notas sobre: Horneado húmedo + ventil.



Esta función se utilizaba para cumplir con los requisitos de categoría de eficiencia energética y ecodiseño según EU 65/2014 y EU 66/2014. Pruebas conforme a EN 60350-1.

La puerta del horno debe estar cerrada durante la cocción para que la función no se interrumpa y que el horno funcione con la máxima eficiencia energética posible.

Para las instrucciones de cocción, consulte el capítulo "Consejos", Horneado húmedo + ventil.. Puede consultar recomendaciones generales para ahorrar energía en el capítulo "Eficiencia energética", bajo consumo energético.

7. FUNCIONES DEL RELOJ

7.1 Funciones del reloj



función de reloj	Aplicación
 Hora	Ajustar, modificar o comprobar la hora.
 Duración	Programar la duración del funcionamiento del horno.
 Avisador	Para configurar una cuenta atrás. Esta función no influye en el funcionamiento del horno. Puede ajustar esta función cualquier momento, incluso si el horno está apagado.

7.2 Cómo configurar: Funciones del reloj

Cómo cambiar: Hora

 - parpadea al conectar el aparato a la corriente eléctrica si ha habido un corte de corriente o si no está ajustado el temporizador.

Paso 1  - pulse repetidamente.  - empieza a parpadear.





Paso 2 ,  - pulse para ajustar la hora.
Después de unos 5 segundos, el parpadeo cesa y la pantalla indica la hora ajustada.

 - pulse repetidamente para cambiar la hora del día.  - empieza a parpadear.

Cómo configurar: Duración

Paso 1 Programe una función del horno y la temperatura.

Paso 2  - pulse repetidamente.  - empieza a parpadear.



Paso 3 ,  - pulse para establecer la duración.
La pantalla muestra: 
 - parpadea cuando termina el tiempo establecido. La señal suena y el horno se apaga.

Paso 4 Pulse cualquier tecla para desconectar la señal.

Paso 5 Gire los mandos a la posición de apagado.

Cómo configurar: Avisador

Paso 1  - pulse repetidamente.  - empieza a parpadear.

Paso 2 ,  - pulse para ajustar la hora.
La función empieza automáticamente tras 5 segundos.
Al finalizar el tiempo ajustado suena una señal.

Paso 3 Pulse cualquier tecla para desconectar la señal.

Cómo configurar: Avisador

Paso 4 Gire los mandos a la posición de apagado.

Instrucciones para cancelar: Funciones del reloj

Paso 1  - pulse repetidamente hasta que el símbolo de la función de reloj empiece a parpadear.

Paso 2 Mantenga pulsada: .
La función de reloj se apaga después de unos segundos.

8. USO DE LOS ACCESORIOS



ADVERTENCIA!

Consulte los capítulos sobre seguridad.

también son dispositivos anti-vuelco. El borde elevado que rodea la bandeja evita que los utensilios de cocina resbalen de la parrilla.

8.1 Inserción de accesorios

Una pequeña muesca en la parte superior aumenta la seguridad. Las hendiduras

Parrilla:

Inserte la parrilla entre las guías del carril .

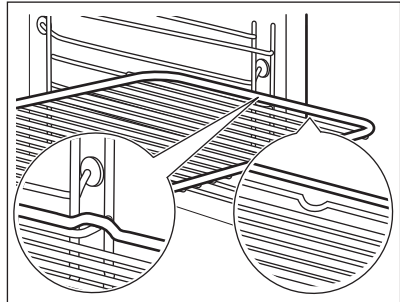

Bandeja /Bandeja honda:

Introduzca la bandeja entre las guías del carril de apoyo.

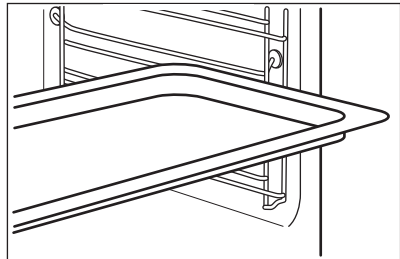

Parrilla, Bandeja /Bandeja honda:

Posicione la bandeja entre las guías del carril de apoyo y la parrilla en las guías de encima.

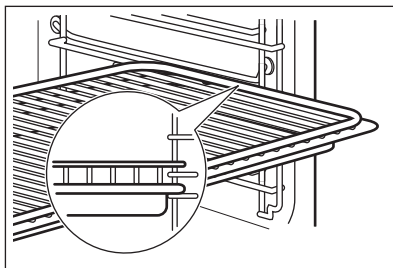

9. FUNCIONES ADICIONALES

9.1 Ventilador de enfriamiento

Cuando el horno funciona, el ventilador de enfriamiento se pone en marcha automáticamente para mantener frías las

superficies del horno. Una vez apagado el horno, el ventilador sigue funcionando hasta enfriarlo totalmente.

10. CONSEJOS



Consulte los capítulos sobre seguridad.

10.1 Recomendaciones de cocción



La temperatura y los tiempos de cocción de las tablas son meramente orientativos. Dependen de la receta, la calidad y la cantidad de los ingredientes utilizados en cada caso. El comportamiento de su horno puede ser diferente al del que tenía anteriormente. Las siguientes tablas muestran los ajustes recomendados para la temperatura, el tiempo de cocción y la posición de los estantes para tipos específicos de alimentos. Si no encuentra los ajustes para una receta especial, busque otra similar.

10.2 Cara interior de la puerta

La cara interior de la puerta contiene:

- los números de las posiciones de la parrilla.
- información sobre las funciones del horno, posiciones recomendadas de las parrillas y temperatura apropiada para platos.

10.3 Horneado

Para la primera cocción, utilice la temperatura más baja.

El tiempo de cocción puede ampliarse unos 10-15 minutos cuando se hornea repostería en más de una posición.





Los pasteles y las pastas que se hornean a niveles diferentes no siempre se doran de modo uniforme. No es necesario cambiar el ajuste de temperatura si el tueste no es uniforme. Las diferencias se compensarán durante el horneado.

Las bandejas pueden torcerse en el horno durante el horneado. Las distorsiones desaparecen cuando las bandejas se enfrían de nuevo.

10.4 Consejos para hornear

Resultado	Posible causa	Solución
La base de la tarta no se ha horneado lo suficiente.	La parrilla no está en una posición correcta.	Coloque la tarta en un nivel más bajo.
La tarta se hunde y se queda pegajosa o muestra estrías.	La temperatura del horno es demasiado alta.	La próxima vez ajuste una temperatura del horno ligeramente más baja.
	La temperatura del horno es demasiado alta y el tiempo de cocción demasiado corto.	La próxima vez fije un tiempo de horneado más largo y baje la temperatura del horno.
La tarta está demasiado seca.	La temperatura del horno es demasiado baja.	La próxima vez ajuste una temperatura del horno más alta.
	El tiempo de horneado es demasiado largo.	La próxima vez fije un tiempo de horneado más corto.
El pastel se hornea irregularmente.	La temperatura del horno es demasiado alta y el tiempo de cocción demasiado corto.	La próxima vez fije un tiempo de horneado más largo y baje la temperatura del horno.
	La masa del pastel no se distribuye uniformemente.	La próxima vez, distribuya la masa uniformemente en la bandeja.
El pastel no está listo en el tiempo indicado en la receta.	La temperatura del horno es demasiado baja.	La próxima vez ajuste una temperatura del horno un poco más alta.

10.5 Horneado en un solo nivel

 ALI- MENTOS EN MOLDES		 (°C)	 (min)	
Masa brisé - masa quebrada, precaliéntele el horno vacío	Aire caliente	170 - 180	10 - 25	2
Masa brisé: bizcocho	Aire caliente	150 - 170	20 - 25	2
Pastel molde redondo / Brioche	Aire caliente	150 - 160	50 - 70	1
Tarta de Madeira / Tarta de frutas	Aire caliente	140 - 160	70 - 90	1
Tarta de queso	Cocción convencional	170 - 190	60 - 90	1

Use el tercer nivel.

Use la función: Aire caliente.

Utilice una bandeja de horno.

**TARTAS / PASTAS / PANES****(°C)****(min)**

Pastel de azúcar	150 - 160	20 - 40
Tarta de frutas (sobre masa con levadura / bizcocho), utilice una bandeja honda	150	35 - 55
Tarta de fruta sobre masa quebrada	160 - 170	40 - 80

Precalente el horno vacío.

Use la función: Cocción convencional.

Utilice una bandeja de horno.





**TARTAS / PASTAS / PANES****(°C)****(min)**

Brazo de gitano	180 - 200	10 - 20	3
Pan de centeno:	primero: 230	20	1
	después: 160 - 180	30 - 60	
Tarta de almendras y mantequilla / Tartas de azúcar	190 - 210	20 - 30	3
Buñuelos de crema / Bolleritos rellenos de crema	190 - 210	20 - 35	3
Trenza de pan / Roscón	170 - 190	30 - 40	3
Tarta de frutas (sobre masa con levadura / bizcocho), utilice una bandeja honda	170	35 - 55	3
Bizcochos con levadura coronados de guarniciones delicadas (por ej. requesón, crema, natillas)	160 - 180	40 - 80	3
Pastel de navidad	160 - 180	50 - 70	2

Use el tercer nivel.





**GALLETAS****(°C)****(min)**

Galletas de masa quebrada	Aire caliente	150 - 160	10 - 20
Rollitos, precalente el horno vacío	Aire caliente	160	10 - 25
Galletas de masa batida esponjosa	Aire caliente	150 - 160	15 - 20

 GALLETAS		 (°C)	 (min)
Pastas de hojaldre, precaliente el horno vacío	Aire caliente	170 - 180	20 - 30
Galletas de masa de levadura	Aire caliente	150 - 160	20 - 40
Mostachones de almendra	Aire caliente	100 - 120	30 - 50
Galletas de clara de huevo / Merengues	Aire caliente	80 - 100	120 - 150
Rollitos, precaliente el horno vacío	Cocción convencional	190 - 210	10 - 25

10.6 Gratinados y horneados





Use el primer nivel.

		 (°C)	 (min)
Baguetas cubiertas de queso fundido	Aire caliente	160 - 170	15 - 30
Verduras al gratén, precaliente el horno vacío	Grill Turbo	160 - 170	15 - 30
Lasaña	Cocción convencional	180 - 200	25 - 40
Pescado al horno	Cocción convencional	180 - 200	30 - 60
Verduras rellenas	Aire caliente	160 - 170	30 - 60
Dulces horneados	Cocción convencional	180 - 200	40 - 60
Gratén de pasta	Cocción convencional	180 - 200	45 - 60

10.7 Horneado en varios niveles

Use la función: Aire caliente.

Utilice las bandejas de horno.

 TARTAS / PASTAS	 (°C)	 (min)	 2 posiciones
Buñuelos de crema / Bolleritos rellenos de crema, precaliente el horno vacío	160 - 180	25 - 45	1 / 4
Pastel Streusel seco	150 - 160	30 - 45	1 / 4



GALLETAS/PASTELLOS/PASTAS/BOLLOS



(°C)



(min)



2 posiciones

3 posiciones

Rollitos	180	20 - 30	1 / 4	-
Galletas de masa quebrada	150 - 160	20 - 40	1 / 4	1 / 3 / 5
Galletas de masa batida esponjosa	160 - 170	25 - 40	1 / 4	-
Pastas de hojaldre, precaliente el horno vacío	170 - 180	30 - 50	1 / 4	-
Galletas de masa de levadura	160 - 170	30 - 60	1 / 4	-
Mostachones de almendra	100 - 120	40 - 80	1 / 4	-
Galletas de clara de huevo / Merengues	80 - 100	130 - 170	1 / 4	-

10.8 Consejos para asar

Use utensilios para horno resistentes al calor.

Ase la carne magra tapada (puede utilizar papel de aluminio).

Ase los trozos grandes de carne directamente sobre la bandeja o en la parrilla colocada sobre la bandeja.

Para evitar que se queme la grasa, ponga un poco de agua en la bandeja.

Gire el asado al cabo de 1/2 o 2/3 del tiempo de cocción.

Utilice trozos de carne y pescado grandes (1 kg o más).

Durante la cocción, los asados grandes se deben rociar repetidamente con el jugo.

10.9 Asados

Use el primer nivel.



CARNE DE RES



(°C)



(min)

Estofado	1 - 1,5 kg	Cocción convencional	230	120 - 150
Rosbif o filete, poco hecho, precaliente el horno vacío	por cm de grosor	Grill Turbo	190 - 200	5 - 6
Rosbif o filete, al punto, precaliente el horno vacío	por cm de grosor	Grill Turbo	180 - 190	6 - 8



CARNE DE RES



(°C)



(min)

Rosbif o filete, muy hecho, precaliente el horno vacío

por cm de grosor

Grill Turbo

170 - 180

8 - 10



CERDO



Use la función: Grill Turbo.



(kg)



(°C)



(min)

Paletilla / Cuello / Jamón

1 - 1.5

160 - 180

90 - 120

Chuletas / Costillas

1 - 1.5

170 - 180

60 - 90

Pastel de carne

0.75 - 1

160 - 170

50 - 60

Codillo de cerdo precocinado

0.75 - 1

150 - 170

90 - 120



TERNERA



Use la función: Grill Turbo.



(kg)



(°C)



(min)

Ternera asada

1

160 - 180

90 - 120

Codillo de ternera

1.5 - 2

160 - 180

120 - 150



CORDERO



Use la función: Grill Turbo.



(kg)



(°C)



(min)

Pata de cordero / Cordero
asado

1 - 1.5

150 - 170

100 - 120

Silla de cordero

1 - 1.5

160 - 180

40 - 60



CARNE DE CAZA



Use la función: Cocción convencional.



(kg)



(°C)



(min)

Silla / Pata de liebre, pre-
caliente el horno vacío

hasta 1

230

30 - 40

Silla de corzo

1.5 - 2

210 - 220

35 - 40

Pierna de corzo

1.5 - 2

180 - 200

60 - 90



AVES



Use la función: Grill Turbo.



(kg)



(°C)



(min)

Aves troceadas

0,2 - 0,25 cada trozo

200 - 220

30 - 50

Pollo, medio

0,4 - 0,5 cada trozo

190 - 210

35 - 50

Pollo, pularda

1 - 1.5

190 - 210

50 - 70

Pato

1.5 - 2

180 - 200

80 - 100

Ganso

3.5 - 5

160 - 180

120 - 180

Pavo

2.5 - 3.5

160 - 180

120 - 150

Pavo

4 - 6

140 - 160

150 - 240



PESCADO (AL VAPOR)



Use la función: Cocción convencional.



(kg)



(°C)



(min)

Pescado entero

1 - 1.5

210 - 220

40 - 60

10.10 Horneado crujiente con: Función pizza



PIZZA



Use el primer nivel.



(°C)



(min)

Tartas 180 - 200 40 - 55

Flan de espinacas 160 - 180 45 - 60

Quiche Lorraine / Flan suizo 170 - 190 45 - 55

Tarta de queso 140 - 160 60 - 90

Pastel de verduras 160 - 180 50 - 60



PIZZA



Precaliente el horno vacío antes de cocinar.



Use el segundo nivel.



(°C)



(min)

Pizza, base fina, 200 - 230 15 - 20
utilice una bandeja honda



PIZZA



Precaliente el horno vacío antes de cocinar.



Use el segundo nivel.



(°C)



(min)

Pizza, base gruesa 180 - 200 20 - 30

Pan sin levadura 230 - 250 10 - 20

Empanada de masa de hojaldre 160 - 180 45 - 55

Flammkuchen (tarta flambeada) 230 - 250 12 - 20

Pierogi 180 - 200 15 - 25

10.11 Grill

Precaliente el horno vacío antes de cocinar.

Cocine al grill solo trozos de carne o pescado poco gruesos.

Coloque una bandeja en el primer nivel para recoger la grasa.



GRILL



Use la función: Grill



(°C)



(min)
1ª cara



(min)
2ª cara



	(°C)	(min) 1ª cara	(min) 2ª cara	
Redondo al horno	210 - 230	30 - 40	30 - 40	2
Solomillo de res	230	20 - 30	20 - 30	3
Lomo de cerdo	210 - 230	30 - 40	30 - 40	2
Lomo de ternera	210 - 230	30 - 40	30 - 40	2
Silla de cordero	210 - 230	25 - 35	20 - 25	3
Pescado entero, 0,5 kg - 1 kg	210 - 230	15 - 30	15 - 30	3 / 4

10.12 Congelados



DESCONGELACIÓN



Use la función: Aire caliente.



(°C)



(min)



	(°C)	(min)	
Pizza congelada	200 - 220	15 - 25	2
Pizza americana congelada	190 - 210	20 - 25	2
Pizza refrigerada	210 - 230	13 - 25	2
Pizzetas congeladas	180 - 200	15 - 30	2
Patatas fritas finas	200 - 220	20 - 30	3
Patatas fritas gruesas	200 - 220	25 - 35	3
Porciones / Croquetas	220 - 230	20 - 35	3
Patatas asadas con cebolla	210 - 230	20 - 30	3
Lasaña / Canelones frescos	170 - 190	35 - 45	2
Lasaña / Canelones congelados	160 - 180	40 - 60	2
Queso al horno	170 - 190	20 - 30	3
Alitas de pollo	190 - 210	20 - 30	2





10.13 Descongelar

Extraiga el alimento del envase y colóquelo en un plato.

No tape la comida, porque puede prolongar el tiempo de descongelación.

Use el primer nivel.

Para grandes porciones de comida, coloque un plato vacío del revés sobre la base en el interior del horno. Coloque la comida en un plato hondo y sobre el plato del interior del horno. Retire los soportes si es necesario.

	 (kg)	 (min) Tiempo de des- congelación	 (min) Tiempo de des- congelación adi- cional	
Pollo	1	100 - 140	20 - 30	Dele la vuelta a media cocción.
carne	1	100 - 140	20 - 30	Dele la vuelta a media cocción.
Trucha	0.15	25 - 35	10 - 15	-
Fresas	0.3	30 - 40	10 - 20	-
Mantequilla	0.25	30 - 40	10 - 15	-
Nata	2 x 0,2	80 - 100	10 - 15	Monte la nata aunque queden puntos ligeramente congelados.
Pasteles	1.4	60	60	-

10.14 Conservar

Use la función Calor inferior.

Utilice únicamente botes de conserva del mismo tamaño disponibles en el mercado.

No utilice botes con cierre hermético (twist-off) o de bayoneta ni latas metálicas.

Use el primer nivel.

No coloque más de seis botes de un litro en la bandeja.



Llene los botes por igual y ciérrelos con una abrazadera.



Los botes no se pueden tocar entre sí.



Ponga aproximadamente 1/2 litro de agua en la bandeja de horno para que haya un grado de humedad suficiente en el horno.

Cuando el líquido de los botes comience a formar burbujas (aprox. después de 35 - 60 minutos con frascos de 1 litro), apague el horno o reduzca la temperatura a 100 °C (consulte la tabla).

Ajuste la temperatura a 160 - 170 °C.

 FRUTAS SIL- VESTRES	 (min) Cocer hasta que empiecen a subir burbujas
Fresas / Arándanos / Frambuesas / Uvas espina maduras	35 - 45

 FRUTA DE HUESO		
	(min) Cocer hasta que empiecen a subir burbujas	(min) Continuar la cocción a 100 °C
Melocotones / Membrillos / Ciruelas	35 - 45	10 - 15

 VERDURAS DURAS		
	(min) Cocer hasta que empiecen a subir burbujas	(min) Continuar la cocción a 100 °C
Zanahorias	50 - 60	5 - 10
Pepinos	50 - 60	-
Encurtidos variados	50 - 60	5 - 10
Colinabo / Guisantes / Espárragos	50 - 60	15 - 20

10.15 Desechar alimentos - Aire caliente

Cubra las bandejas con papel vegetal o de hornear.

10.16 Horneado húmedo + ventil.. accesorios recomendados

Utilice molde y recipientes oscuros y mates. Tiene mejor absorción del calor que los platos de color claro y brillantes.



Bandeja para pizza

Oscuro, mate
28 cm de diámetro

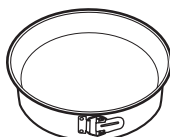

Bandeja para hornear

Oscuro, mate
26 cm de diámetro



Ramequines

Cerámica
8 cm de diámetro,
5 cm de altura

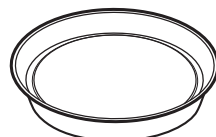



Molde para base

Oscuro, mate
28 cm de diámetro



Para obtener mejores resultados, pare el horno a la mitad del tiempo de secado, abra la puerta y déjelo enfriar, a ser posible durante una noche para terminar el secado.

Para 1 bandeja, use el tercer nivel.

Para dos bandejas, use el primer y cuarto nivel.





 VERDURAS		
	(°C)	(h)
Judías	60 - 70	6 - 8
Pimientos	60 - 70	5 - 6
Verduras para sopa	60 - 70	5 - 6
Setas	50 - 60	6 - 8
Hierbas aromáticas	40 - 50	2 - 3

Ajuste la temperatura a 60 - 70 °C.

 FRUTA	
	(h)
Ciruelas	8 - 10
Albaricoques	8 - 10
Manzanas en rodajas	6 - 8
Peras	6 - 9







10.17 Horneado húmedo + ventil.

Para obtener el mejor resultado, siga las recomendaciones de la tabla siguiente.

	 (°C)	 (min)	
Bastoncillos de pan, 0,5 kg en total	190 - 200	50 - 60	3
Vieiras en su concha	180 - 200	30 - 40	4
Pescado entero en sal, 0,3 - 0,5 kg	190 - 200	45 - 50	4
Pescado entero en papel de hornear, 0,3 - 0,5 kg	190 - 200	50 - 60	3
Amaretti (20; 0,5 kg en total)	170 - 180	40 - 50	3
Crumble de manzana	190 - 200	50 - 60	4
Muffins de chocolate (20; 0,5 kg en total)	160 - 170	35 - 45	3

10.18 Información para los institutos de pruebas

Pruebas según: EN 60350, IEC 60350.

 HORNEADO EN UN NIVEL. Horneado en moldes				
		 (°C)	 (min)	
Bizcocho sin grasa	Aire caliente	140 - 150	35 - 50	2
Bizcocho sin grasa	Cocción convencional	160	35 - 50	2
Tarta de manzana, 2 moldes, Ø 20 cm	Aire caliente	160	60 - 90	2
Tarta de manzana, 2 moldes, Ø 20 cm	Cocción convencional	180	70 - 90	1



HORNEADO EN UN NIVEL. Galletas



Use el tercer nivel.



(°C)



(min)

Mantecados / Masa quebrada	Aire caliente	140	25 - 40
Mantecados / Masa quebrada, precaliente el horno vacío	Cocción convencional	160	20 - 30
Pastelillos, 20 unidades por bandeja, precaliente el horno vacío	Aire caliente	150	20 - 35
Pastelillos, 20 unidades por bandeja, precaliente el horno vacío	Cocción convencional	170	20 - 30



HORNEADO EN VARIOS NIVELES. Galletas



(°C)



(min)



Mantecados / Masa quebrada	Aire caliente	140	25 - 45	1 / 4
Pastelillos, 20 unidades por bandeja, precaliente el horno vacío	Aire caliente	150	23 - 40	1 / 4
Bizcocho sin grasa	Aire caliente	160	35 - 50	1 / 4



GRILL



Precaliente el horno vacío 5 minutos.



Grill con la temperatura ajustada al máximo.



(min)



Tostadas	Grill	1 - 3	5
Bistec de vaca, dar la vuelta a media cocción	Grill	24 - 30	4

11. MANTENIMIENTO Y LIMPIEZA



ADVERTENCIA!

Consulte los capítulos sobre seguridad.

11.1 Notas sobre la limpieza



Agentes limpiadores

Limpe la parte delantera del horno con un paño suave humedecido en agua templada y jabón suave.

Utilice un producto de limpieza para limpiar las superficies metálicas.

Limpe las manchas con un detergente suave.



Uso diario

Limpe el interior después de cada uso. La acumulación de grasa u otros residuos puede provocar un incendio.

No guarde la comida en el horno más de 20 minutos. Seque el interior con un paño suave después de cada uso.



Accesorios

Limpe todos los accesorios después de cada uso y déjelos secar. Use un paño suave humedecido en agua caliente y detergente suave. No lave los accesorios en el lavavajillas.

No limpie los accesorios no adherentes utilizando un limpiador abrasivo ni objetos afilados.

11.2 Cómo quitar: Apoyos de baldas

Para limpiar el horno, retire los carriles de apoyo.

Paso 1 Apague el horno y espere a que esté frío.

Paso 2 Tire de la parte delantera del carril de apoyo para separarlo de la pared lateral.

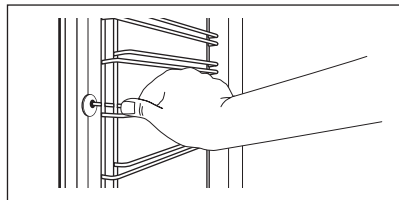

Paso 3 Tire del extremo trasero del carril de apoyo para despegarlo de la pared lateral y sáquelo.

Paso 4 Coloque los carriles de apoyo en el orden inverso.

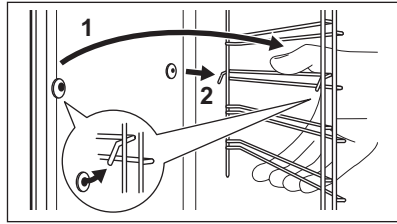

11.3 Cómo quitar: Grill



ADVERTENCIA!
Existe riesgo de quemaduras.

Paso 1 Apague el horno y espere a que esté frío para limpiarlo.
Retire los carriles telescópicos.

Paso 2 Sujete las esquinas de la parrilla. Tire hacia fuera hasta sentir la presión del muelle y extraiga de los dos soportes. El grill se separa del techo por la parte delantera.

Paso 3 Limpie el techo del horno con agua templada, un paño suave y detergente suave. Deje que se seque.

Paso 4 Instale el grill siguiendo el orden inverso.

Paso 5 Coloque los carriles de apoyo.

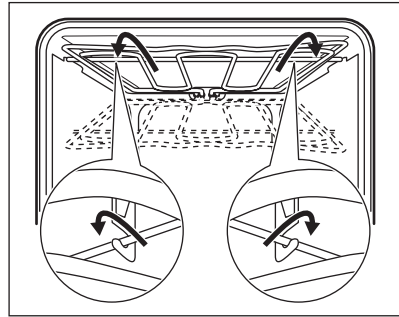

11.4 Cómo quitar e instalar:

El número de paneles de cristal es diferente según el modelo.



PRECAUCIÓN!
Maneje con cuidado el vidrio, especialmente alrededor de los bordes del panel frontal. El cristal puede romperse.

11.5 Cómo cambiar: Bombilla



ADVERTENCIA!
Riesgo de descarga eléctrica.
La lámpara puede estar caliente.

Antes de reemplazar la bombilla:

Paso 1	Paso 2	Paso 3
Apague el horno. Espere hasta que el horno esté frío.	Desconecte el horno de la red.	Coloque un paño en el fondo de la cavidad.

Bombilla superior

Paso 1 Gire la tapa de cristal para extraerla.

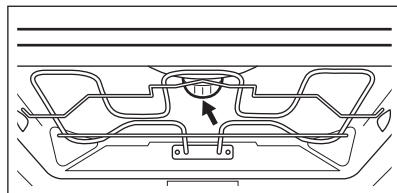

Paso 2 Limpie la tapa de cristal.

Paso 3 Cambie la bombilla por otra apropiada termorresistente hasta 300 °C.

Paso 4 Coloque la tapa de cristal.

12. SOLUCIÓN DE PROBLEMAS



ADVERTENCIA!

Consulte los capítulos sobre seguridad.

12.1 Qué hacer si...

En cualquier caso no incluido en esta tabla, por favor contacte con un Centro de Servicio Autorizado.

Problema	Compruebe que...
El horno no calienta.	Ha saltado el fusible.
La pantalla muestra "12.00".	Ha habido un corte de alimentación. Ajusta el reloj.

Problema	Compruebe que...
La bombilla no funciona.	La bombilla se ha fundido.

12.2 Datos de servicio

Si no logra subsanar el problema, póngase en contacto con su distribuidor o el centro de servicio técnico.

Los datos que necesita para el centro de servicio técnico se encuentran en la placa de características. La placa de régimen se encuentra en el marco delantero de la cavidad del horno. No retire la placa de características de la cavidad del horno.

Es conveniente que anote los datos aquí:

Modelo (MOD.)

Número de producto (PNC)

Número de serie (S.N.)

13. EFICACIA ENERGÉTICA

13.1 Información del producto y Hoja de información del producto*

Nombre del proveedor

AEG

Identificación del modelo

BEK435220M 944188023

Índice de eficiencia energética	81.2
Clase de eficiencia energética	A+
Consumo de energía con carga estándar, modo convencional	0.99 kWh/ciclo
Consumo de energía con carga estándar, modo con ventilador	0.69 kWh/ciclo
Número de cavidades	1
Fuente de calor	Electricidad
Volumen	71 l
Tipo de horno	Horno empotrado
Masa	34.0 kg

* Para la Unión Europea según los Reglamentos de la UE 65/2014 y 66/2014.
 Para la República de Bielorrusia según STB 2478-2017, apéndice G; STB 2477-2017, anexos A y B.
 Para Ucrania según 568/32020.

La clase de eficiencia energética no es aplicable a Rusia.

EN 60350-1 - Aparatos electrodomésticos - Parte 1: Placas, hornos, hornos de vapor y parrillas - Métodos para medir el rendimiento.

13.2 Ahorro de energía



El horno tiene características que le ayudan a ahorrar energía durante la cocina de cada día.

Asegúrese de que la puerta del horno está cerrada cuando el horno funciona. No abra la puerta del horno muchas veces durante la cocción. Mantenga limpia la junta de la puerta y asegúrese de que está bien fijada en su posición.

Utilice utensilios de cocina de metal para mejorar el ahorro energético.

En la medida de lo posible, no precaliente el horno antes de cocinar.

Reduzca al máximo el tiempo entre horneados cuando prepare varios platos de una vez.

Cocción con ventilador

En la medida de lo posible, utilice las funciones de cocción con ventilador para ahorrar energía.

Calor residual

Para una duración de la cocción superior a 30 minutos, reduzca la temperatura del horno un mínimo de 3 - 10 minutos antes de que transcurra el tiempo de cocción. El calor residual dentro del horno seguirá cocinando.

Utilice el calor residual para calentar otros platos.

Mantener calor

Si desea utilizar el calor residual para mantener calientes los alimentos, seleccione el ajuste de temperatura más bajo posible.

Horneado húmedo + ventil.

Función diseñada para ahorrar energía durante la cocción.

14. ASPECTOS MEDIOAMBIENTALES

Recicle los materiales con el símbolo .
 Coloque el material de embalaje en los

contenedores adecuados para su reciclaje. Ayude a proteger el medio ambiente y la salud pública, así como a reciclar residuos

de aparatos eléctricos y electrónicos. No deseche los aparatos marcados con el símbolo  junto con los residuos

domésticos. Lleve el producto a su centro de reciclaje local o póngase en contacto con su oficina municipal.

www.aeg.com/shop



867361882-A-242020



AEG